



# 2211 DISC CHISEL DISC



## 2211 DISC CHISEL DISC FEATURES

**3** YEAR WARRANTY

The 2211 Disc Chisel Disc from Landoll will size and incorporate heavy residue while removing yield robbing compaction, yet leaves the surface level behind the machine. The new 2211 tackles today's toughest hybrids, leaving the residue in the best position for accelerated decomposition.

Adjustable gang angles front and rear, combined with hydraulic gang heights, allow the operator to fine tune the unit for their desired performance. Available in 9, 11, 13 and 15 shank models, with the 13 and 15 featuring folding rear gangs for reduced transport widths. All units feature single point depth control, heavy-duty trunnion style bearings on the front and rear gangs, walking tandems, grease free bushings in the rockshaft area and are all backed by a 3-year Warranty.



### Adjustable Disc Gang Angle

Front and rear disc gangs can be adjusted to leave the amount of residue desired. This will allow the operator to fine tune the unit. Front gangs are adjustable from an aggressive 18° to 14°, and the rear gangs from 16° to 12° for secondary sizing and leveling.



### Self Aligning Disc Gang Bearing

Cushioned gang hangers will flex, which requires the bearing to realign. Bearings are triple lip sealed and cannot be damaged by over-greasing. The bearings are covered by a 3-year warranty.



### UHMW Technology

The rockshaft and the front and rear disc gangs pivot on UHMW polymer, eliminating metal-to-metal contact and the need for greasing. Many other high wear areas on the machine are protected by some form of a maintenance-free feature, eliminating wear and daily greasing.



### Heavy Duty Auto-Reset Shanks

Shanks with 1,750 lbs. of point load and 32" of underframe clearance are positioned on 15" spacing for optimum residue flow.

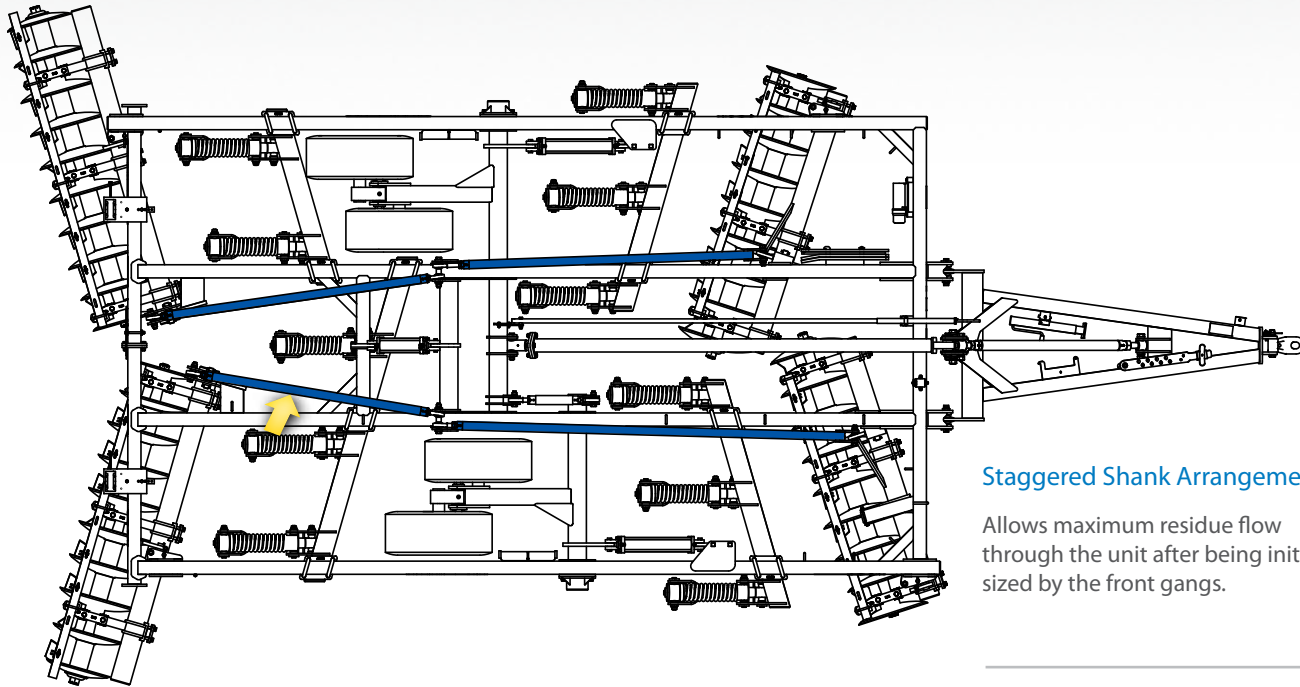

### Staggered Shank Arrangement

Allows maximum residue flow through the unit after being initially sized by the front gangs.

### Hydraulic Disc Gangs

The front and rear gangs are connected together and the height is adjusted hydraulically with one cylinder. The unit is easier to set in the field than competitive units that adjust the gangs individually.

### Staggered Overlapping Front Disc Gang

The front gang features a staggered overlapping design to cut the center clean. This feature allows the rear gangs to run deeper for more sizing and mixing without causing a ridge in the center of the machine.



### Heavy-Duty Scrapers

Scrapers are mounted on a heavy-duty spring steel arm and feature two mounting positions on the scraper blade for adjustment, depending on the soil conditions. Dual scrapers are located at each bearing location, reducing the amount of residue that can enter the bearing area, reducing the chance for plugging.



### Disc Blades & Spacing

The gangs feature a 1-3/4" gang shaft, with 24" diameter by 1/4" thick blades with 10-1/2" spacing on the front and rear. This combination provides maximum residue coverage and superior leveling capabilities.

## 2211 DISC CHISEL DISC SPECIFICATIONS

### STANDARD SPECIFICATIONS

#### DISC GANGS:

- Hydraulic depth adjustment on gangs
- Adjustable gang angle, 18° or 14° front and 16° or 12° rear gangs
- 24" diameter, ¼" thick blades with 10 ½" spacing front and rear
- Round 1 ¾" gang shaft and triple lip trunnion bearings
- Cushion bearing standards w/ scraper bars mounted to them
- Adjustable scrapers

#### SHANKS:

- Auto-reset shanks with 1,750 lb. point load, 14" trip height and 32" under frame clearance
- 2" Straight chisel spikes - (Reversible)

#### SPINDLES, TIRES AND WHEELS:

- (4) 12.5L x 15, Highway Service Tires (Load F) with 8 bolt wheels and 2 ¼" slip in spindles, 2211-9 & 11, and 3" spindles on 2211-13 & 15
- Walking tandems standard on all sizes

#### HITCH:

- Self-leveling hitch with manual adjustment
- Cast single lip w/ Cat. III, 2211-9 & 11
- Cast single lip w/ Cat. IV on model 2211-13 & 15

#### OTHER:

- Safety chain, light kit and SMV emblem
- Blue powder coat paint
- Gang and adjustment wrenches



2211-13 & 15 Shank Models feature folding rear gangs for reduced transport width. Transport Height on 13 & 15 Shank Folding Models: 13'-4" & 14'-0"

### OPTIONAL EQUIPMENT

- Single lip hitch, Cat. III in lieu of Cat. IV

#### CHOICE OF POINTS OR SHOVELS:

- 4" Twisted Shovels
- 2" Straight points in lieu of 4" twisted shovels
- 2" Straight points w/chrome cap in lieu of standard (for non-rocky areas)

### MODEL SPECIFICATIONS

Model Number	Front and Rear Gang Cut		Transport Width	No. of Shanks	No. of Blades F/R	Estimated Weight	Shank Working Width
	Front	Rear					
2211-9	11'-10"	14'-7"	15'-4"	9 on 15"	16/18	13,480 lbs.	11'-3"
2211-11	13'-7"	16'-4"	17'-1"	11 on 15"	18/20	14,410 lbs.	13'-9"
2211-13	16'-10"	19'-10"	17'-9"	13 on 15"	22/24	20,600 lbs.	16'-3"
2211-15	18'-6"	21'-7"	18' 11"	15 on 15"	24/26	21,560 lbs.	18'-9"

Transport Height on 13 & 15 Shank Folding Models: 13'-4" & 14'-0"