

DREXEL®

MODEL SL30 **SWINGMAST® VNA** ELECTRIC MULTI-PURPOSE **3,000 LB (1,364KG) CAPACITY**

The Landoll SwingMast® Electric VNA Forklift, with a 90° pivoting and shifting mast maximizes cube utilization while providing front loader versatility. The SwingMast® also can handle, store and transport long loads as a side loader for long load handling applications.



FEATURES

- 3,000 lbs (1,364kg) Capacity
- Lift Heights to 313" (7.92M)
- 60" (1.5M) Stacking Aisle
- 20" (508mm) Mast Sideshift
- 3" (76mm) Fork Side Reach

DRIVETRAIN

- Independently Driven Front Wheels
- Dual Front Wheel Hydraulic Disk Brakes
- Articulating Rear Steer Axle
- Large Diameter Rubber Drive and Poly Steer Tires
- Heavy Duty Planetary Transmission

ELECTRICAL

- 48 Volt Electrical System
- Separately Excited Dual Traction Motor Controller
- Battery Discharge Indicator with Lift Interrupt
- Provisions for RF Terminals
- Large Battery Compartment

ERGONOMIC & SAFETY

- Hydraulic Power Steering
- Comfortable Seated Operation with All Truck Controls within Easy Reach
- Safety Dead Man Seat Switch
- Clear View Triple or Quad Mast
- 4 Post, Heavy-Duty Overhead Guard

ENGINEERING

- Forward and Rearward Mast Tilt
- Heavy Duty Chassis Design
- Front Pivot Via 2 Taper Roller Bearings, with 3 Year Warranty on Pivot/Shift
- Accepts Class II Attachments
- Easily Accessible Components for Low Cost Maintenance
- Freezer Option Available
- Wire Guidance Option



LANDOLL CORPORATION

MATERIAL HANDLING PRODUCT DIVISION

WWW.LANDOLL.COM/MHP

SwingMast® SL30

3,000 LBS (1,364KG)

ELECTRIC-MULTI-PURPOSE VNA AND SIDELOADING
SWINGMAST FORKLIFT TRUCK
TECHNICAL & DIMENSION DATA



MODEL		SL30	
Capacity		lbs/kg	3,000 / 1,364
Load Center		in/mm	24 / 600
Power Source			Battery, electric
Weight with Battery		lbs/kg	12,600 / 5,727
Travel Speed	Loaded	mph/kph	6 / 9.7
	Unloaded	mph/kph	6.5 / 10.5
Lift Speed	5,500 lbs./2,495kg	fpm/mpm	50 / 15
	Unloaded	fpm/mpm	70 / 21.5
Lower Speed	Loaded	fpm/mpm	90 / 27.5
	Unloaded	fpm/mpm	60 / 18.5
Mast Tilt	Forward/Backward	deg	3 / 4
Lost Load Center	a With Triple Mast	in/mm	25 / 635
Wheelbase	b	in/mm	53.5 / 1,359
Overall Length to Face of Forks	c With Triple Mast	in/mm	95 / 2,413
Underclearance	d	in/mm	4.5 / 114
Cab Floor Height	e	in/mm	31 / 787
Seat Height	f	in/mm	52 / 1,321
Overhead Guard Height	g	in/mm	87 / 2,210
Chassis Width	h	in/mm	44.5 / 1,130
Mast Shift	i	in/mm	20 / 508
Side Reach	j	in/mm	3 / 76
Side Deck Height	k	in/mm	42.5 / 1,080
Side Deck Width	l	in/mm	15.5 / 394
Fork Carriage Width	m	in/mm	37 / 940
Fork Length		in/mm	40 / 1,016
Gradeability	Loaded	%	15
Lift Motor Rating		kW	9
Steer Motor Rating		kW	1.5
Drive Motor Rating	2 each	kW	5.5 x 2
Wheel Sizes	Front (2 each)	in/mm	20x9 / 508x229
	Rear (2 each)	in/mm	14x5 / 356x127
Battery Recommended	Electric 72 Volt	kWh	35-39
Minimum Battery Weight		lbs/kg	3,250 / 1,477
Control Type	Traction, Dual		Separately Excited
	Hydraulic		Mosfet

MAST DIMENSIONS

LIFT HEIGHT		CLOSED HEIGHT		FREE LIFT		EXTENDED HEIGHT	
Inches	Meters	Inches	Meters	Inches	Meters	Inches	Meters
3-STATE FULL FREE LIFT							
188	4.78	85	2.16	61	1.55	224	5.69
198	5.03	89	2.26	65	1.65	234	5.94
216	5.49	97	2.46	73	1.85	252	6.40
224	5.69	100	2.54	76	1.93	260	6.60
240	6.10	108	2.74	84	2.13	276	7.01
258	6.55	117	2.97	93	2.36	294	7.47
276	7.01	124	3.15	100	2.54	312	7.92
4-STATE FULL FREE LIFT							
250	6.35	89	2.26	65	1.65	286	7.26
276	7.01	97	2.46	73	1.85	312	7.92
294	7.47	103	2.62	79	2.01	330	8.38
312	7.92	109	2.77	85	2.16	348	8.84

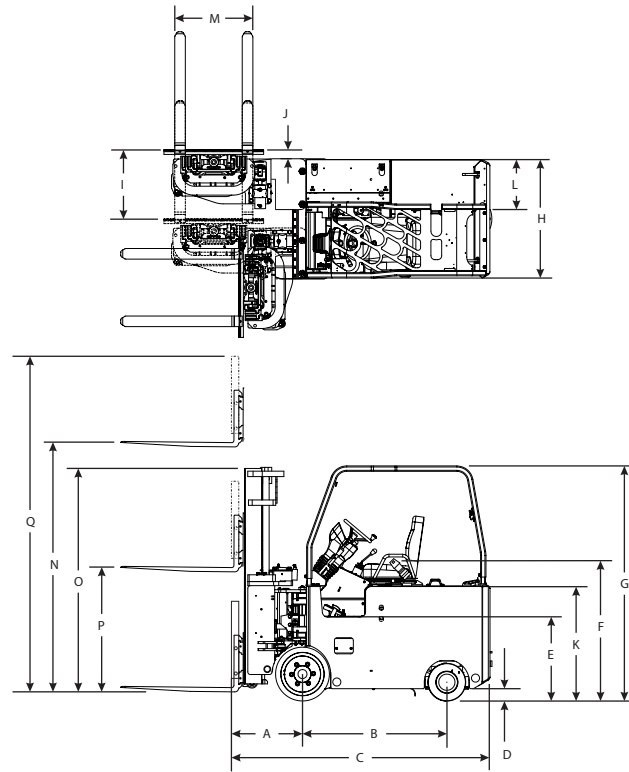

AISE DIMENSIONS

LOAD DEPTH X WIDTH	MINIMUM CLEAR AISLE
40" x 48" (1,000 X 1,200 mm)	56" (1,422 mm)
48" x 40" (1,200 x 1,000 mm)	60" (1,524 mm)
MIN. CLEAR TRANSFER AISLE	144" (3,658 mm)

RECOMMENDED BATTERY

Battery Designation: 24-100-21, 48 volt, 1000 AHC (6 hour rate)
Battery weight min: 3,250 lbs (1477 kg) - Max. 3,900 lbs. (1773 kg)
Leads are at position A, 36" long, with SB 350 amp blue connector
Nominal size: 33" x 38 9/16" x 25 5/8" (84 x 98 x 65 cm)
Standard compartment size: 33 1/2" x 38 5/8" x 25 3/4" (85 x 98 x 65 cm)



The specifications contained in this spec sheet are subject to change at any time without notice. Actual dimensions and performance data given herein may vary due to manufacturing tolerances.

1900 NORTH STREET • MARYSVILLE, KS 66508 • (800).428.5655 • www.landoll.com/mhp

