

# DREXEL®

## **MODEL SL80** **SWINGMAST® VNA/SIDELADING** **ELECTRIC MULTI-PURPOSE** **8,000 LB (3,636KG) CAPACITY**

The Landoll SwingMast® Electric VNA Forklift, with a 90° pivoting and shifting mast, maximizes cube utilization while providing front loader versatility. The SwingMast® can handle, store and transport long loads as a side loader for long load handling applications.

### **STANDARD FEATURES**

- Four Wheel Configuration - 8,000 lbs (3,636kg) Capacity
- 72 Volt Electrical System
- Curtis SEPEX Dual Traction Motor Controllers
- Curtis Series Hydraulic Motor Controller
- Battery Discharge Indicator with Lift Interrupt
- Hydrostatic Power Steering
- 30" (762mm) of Shift-Includes 3" (76mm) of Reach
- 40" (1,016mm) Long Shank Forks with Standard Taper
- Poly Drive and Steer Tires
- 42" (1066mm) High Load Backrest,
- Type E Construction
- Anderson SBX350 Green Connector
- Seatbelt (Retractable)
- Horizontal Fork Indicator, Overhead Guard
- Key Switch, Hand Parking Brake and Hour Meter
- Meets ANSI B56.1

### **OPTIONAL FEATURES**

- EE Construction (Includes Battery Side Cover)
- Non-standard Fork Lengths
- Dual Overhead Guard Mounted LED Headlights
- Dual Rear Safety LED Light Bars
- Safety Flashing LED Light
- Backup Alarm - Beeping Tone ("Smart" dB Adjusting)
- Fire Extinguisher - OHG Post Mounted
- Cold storage conditioning to -20° F (-29° C)
- Roller Slide-out Battery Tray
- Laser Fork Height Indicator
- Fork Positioner
- Keyless Key Pad On-Off
- Long Load Handling Package
- Auxiliary Hydraulics
- Overload Sensor with Alarm



**LANDOLL CORPORATION**  
MATERIAL HANDLING PRODUCT DIVISION  
[WWW.LANDOLL.COM/MHP](http://WWW.LANDOLL.COM/MHP)

# SwingMast® SL80

## 8,000 LBS (3,636KG)

ELECTRIC-MULTI-PURPOSE VNA AND SIDELOADING SWINGMAST FORKLIFT TRUCK  
**TECHNICAL & DIMENSION DATA**



MODEL		SL80	
Capacity		lbs/kg	8,000 / 3,636
Load center		in/mm	24 / 600
Power source			Battery, electric
Weight with battery		lbs/kg	20,900 / 9,500
Travel speed	Loaded	mph/kph	6.9 / 11.1
	Unloaded	mph/kph	7.7 / 12.3
Lift speed	Loaded (5,500 lbs/2,495 kg)	fpm/mpm	55 / 16.7
	Unloaded	fpm/mpm	70 / 21.3
Lower speed	Loaded	fpm/mpm	95 / 28.9
	Unloaded	fpm/mpm	60 / 18.2
Mast tilt	Forward/Backward	deg	3 / 4
Lost load center	a With triple mast	in/mm	24 / 607
Wheelbase	b	in/mm	56 / 1,422
Overall length to face of forks	c With triple mast	in/mm	109 / 2,769
Underclearance	d	in/mm	4 / 102
Cab floor height	e	in/mm	32 / 889
Seat height	f	in/mm	52 / 1,321
Overhead guard height	g	in/mm	90 / 2,286
Chassis width	h	in/mm	56 / 1,422
Mast shift	i	in/mm	30 / 762
Side reach	j	in/mm	3 / 76
Side deck height	k	in/mm	52 / 1,321
Side deck width	l	in/mm	27 / 686
Fork carriage width	m	in/mm	41 / 1,041
Turning radius	n	in/mm	96.5 / 2,451
Fork length		in/mm	40 / 1,016
Gradeability	Loaded	%	15
Lift motor rating		kW	17.6
Steer motor rating		kW	6.5
Drive motor rating	2 each	kW	7.5 x 2
Wheel sizes	Front (2 each)	in/mm	20x9 / 508x229
	Rear (2 each)	in/mm	16.25x7 / 413x178
Battery recommended	Electric 72 volt	kWh	53-55
Minimum battery weight		lbs/kg	4,300 / 1,955
Control type	Traction, dual		Separately Excited
	Hydraulic		Series

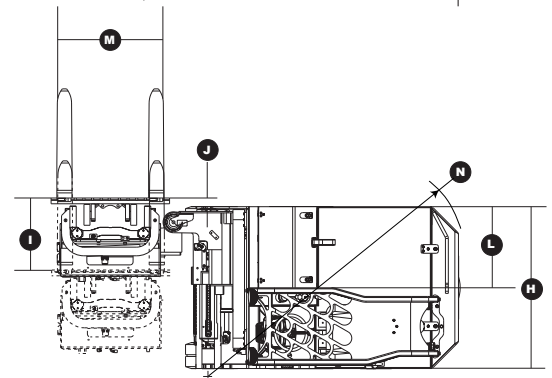
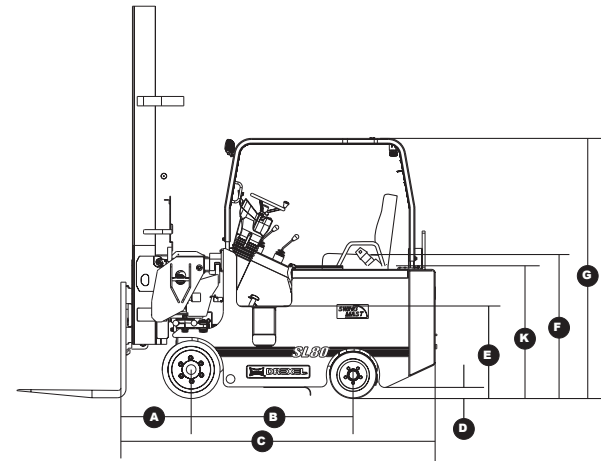

### MAST DIMENSIONS

SL80 MAST OPTIONS					
Lift Height		Lowered Height		Free Lift*	
Inches	Meters	Inches	Meters	Inches	Meters
141	3.58	85	2.16	43	1.09
159	4.04	91	2.31	49	1.24
177	4.50	97	2.46	55	1.40
197	5.00	104	2.64	62	1.57
220	5.59	112	2.84	70	1.78
245	6.22	121	3.07	79	2.01
259	6.58	126	3.20	84	2.13
281	7.14	134	3.40	92	2.34

\* Free Lift Based on 42" (1067mm) high load backrest

### RECOMMENDED BATTERIES

<b>Battery Designation: 36-85-19, 72 volt, 765 AHC (6 hour rate)</b>
Battery weight min: 4,300 lbs (1955 kg) - max. 4,700 lbs. (2136 kg)
Leads: Position D, 36" long, with SBX 350 amp green *connector
Nominal size: 38.38" X 44.38" x 22.62" (98 x 113 x 58 cm)
Compartment size: 39.625" x 45" x 23.5" (100 x 114 x 60 cm)
*SBX connector must have 48 volt 20 amp auxiliary circuit

The specifications contained in this spec sheet are subject to change at any time without notice. Actual dimensions and performance data given herein may vary due to manufacturing tolerances.



1900 NORTH STREET • MARYSVILLE, KS 66508 • (800).428.5655 • www.landoll.com/mhp

