

# DREXEL®

## **MODEL SLT-30/35AC**

### **SwingMast® Lift Truck**

3,000 LB (1,361 KG) AND

3,500 LB (1,588 KG) CAPACITY

#### **STANDARD FEATURES**

- Three-Wheel Configuration
- Rear-Wheel Drive and Steering
- High Visibility Mast, 3 or 4 Stage
- 90° Pivoting and Shifting Mast
- 48 Volt Electrical System
- Single Joystick Control Lever
- Adjustable Driver's Seat (15 Degree Swivel Seat)
- Safety Seat Switch – Cuts Power
- Seat Belts
- Parking Brake, Electric, Mechanically Applied, Electrically Released
- Hydraulic Service Front Wheel Brakes
- AC Traction Control, with Self-Diagnostics, Hour Meter and Battery Discharge Indicator with Lift Interrupt
- AC Hydraulic Pump Control
- Type "E" Construction
- Electronic Power Steering
- Automatic Return –to– Neutral
- SB 350 Blue Battery Connector
- Key Switch
- Covered Battery Compartment
- Battery Compartment Rollers
- Cushion Rubber Drive Tire (1)
- Polyurethane Load Tires (2)
- Horizontal Fork Indicator
- Overhead Guard
- Load Backrest
- Horn



#### **OPTIONAL FEATURES**

- Non-Standard Fork Lengths
- Dual Overhead Guard Mounted LED Headlights
- Dual Rear Safety LED Light Bars
- Safety Flashing LED Light
- Backup Alarm - Beeping Tone ("smart" dB adjusting)
- Fire Extinguisher - OHG Post Mounted
- Cold Storage Conditioning to -20°F (-29°C)
- Laser Fork Height Indicator
- Fork Positioner
- Keyless Key Pad On-Off
- Type EE Construction
- Single Auxiliary Hydraulics
- Landguide Wire Guidance

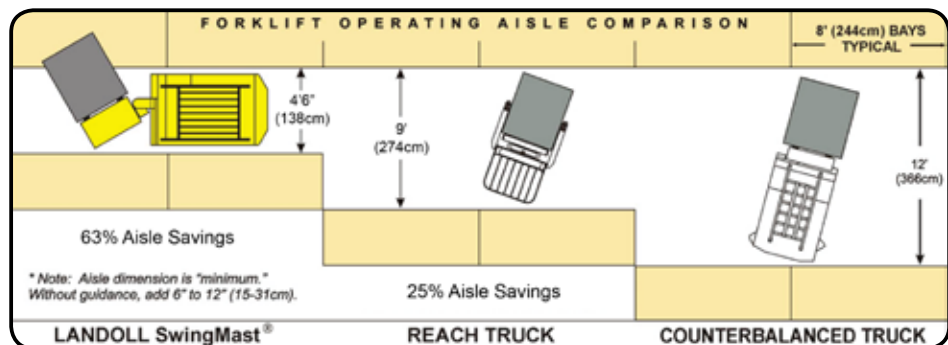

## **LANDOLL CORPORATION**

MATERIAL HANDLING PRODUCT DIVISION

[WWW.LANDOLL.COM/MHP](http://WWW.LANDOLL.COM/MHP)

# SwingMast® SLT-30/35AC Lift Truck

## 3,000 lbs. (1,361 kg) and 3,500 lbs. (1,588 kg) Capacity

### TECHNICAL & DIMENSION DATA



#### TECHNICAL DATA

MODEL			SLT30AC	SLT35AC
Capacity @ 24" L/C		lbs/kg	3,000 / 1,361	3,500 / 1,588
Load Center		in/mm	24 / 600	
Power Source			Battery, electric 48V	
Weight with Battery		lbs/kg	13,225 / 5,999	13,550 / 6,146
Travel Speed	Loaded	mph/kph	6 / 9.7	
	Unloaded	mph/kph	7 / 11.3	
Lift Speed	Loaded	fpm/mpm	95 / 29	
	Unloaded	fpm/mpm	110 / 33.5	
Lower Speed	Loaded	fpm/mpm	80 / 24.4	
	Unloaded	fpm/mpm	75 / 22.8	
Mast Tilt	Fwd/Back	deg.	3 / 4	
Lost Load Center	A	w/ Triple Mast	in/mm	23 / 584
Wheelbase	B		in/mm	56 / 1,422
Overall Length to Fork Face	C	w/ Triple Mast	in/mm	89 / 2,260
Underclearance	D		in/mm	4.5 / 114
Cab Floor Height	E		in/mm	31 / 787
Seat Height	F		in/mm	50.75 / 1,289
Overhead Guard Height	G		in/mm	87 / 2,210
Chassis Width	H		in/mm	45.5 / 1,156
Mast Shift	I		in/mm	20 / 508
Side Reach	J		in/mm	3 / 76
Fork Carriage Width	K		in/mm	31 / 787
Turning Radius	L		in/mm	67 / 1,702
Standard Forks (ITA Class II)			in/mm	40 X 4 X 1.5 / 1,016 X 101 X 38
Gradeability	Loaded	%	10	
Lift Motor Rating		kW	12	
Steer Motor Rating		kW	1.1	
Traction Motor Rating		kW	12	
Wheel Sizes	Front (2 each)	in/mm	18 X 9 X 12.1 / 457 X 229 X 307	
	Rear (1 each)	in/mm	18 X 7 X 12.1 / 457 X 178 X 307	
Control Type	Traction		AC	
	Hydraulic		AC	

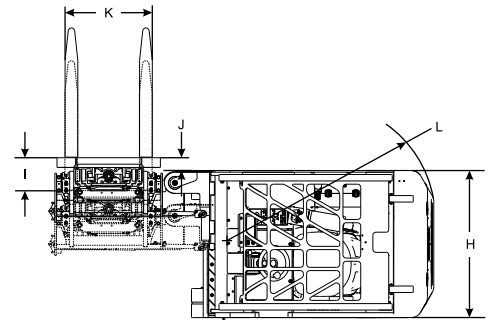
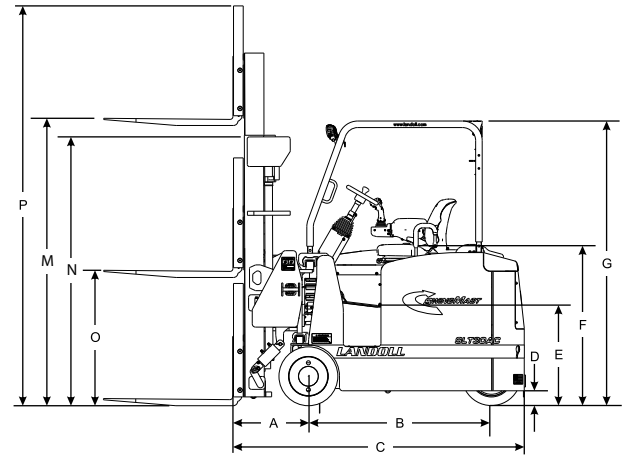

#### MAST DIMENSIONS

M Max. Fork Height		N Collapsed Height		O Free Lift Height *		P Max Overall Height **	
in	m	in	m	in	m	in	m
<b>Triplex (3 Stage) Masts</b>							
188	4.78	83	2.11	47	1.19	224	5.69
198	5.03	87	2.21	51	1.30	234	5.94
205	5.21	90	2.29	54	1.37	241	6.12
216	5.49	95	2.41	59	1.50	252	6.40
224	5.69	98	2.49	62	1.57	260	6.60
240	6.10	106	2.69	70	1.78	276	7.01
258	6.55	115	2.92	79	2.01	294	7.47
272	6.91	121	3.07	85	2.16	308	7.82
<b>Quad (4 Stage) Masts</b>							
250	6.35	87	2.21	51	1.30	286	7.26
258	6.55	89	2.26	53	1.35	294	7.47
276	7.01	95	2.41	59	1.50	312	7.92
294	7.47	101	2.57	65	1.65	330	8.38
312	7.92	107	2.72	71	1.80	348	8.84
* Free lift height based on 36" (914 mm) tall LBR							
** Max overall height based on 36" (914 mm) tall LBR							
Dimensions based on 3" (76.2 mm) mast under clearance							

#### RECOMMENDED BATTERY

Recommended Battery
Battery Designation: 24-125-13, 48 volt, 750 AHC (6 hour rate)
Battery weight min: 2,750 lbs (1,247 kg) - max. 3,300 lbs. (1,497 kg)
Leads: Position D, 24" long, with SB 350 amp blue connector
Nominal size: 38.25" X 20.75" x 30.56" (971 mm x 527 mm x 776 mm)
Battery compartment inside dimensions - 38.5" x 21.5" x 31.5" (978mm x 546mm x 800mm)

The specifications contained in this spec sheet are subject to change at any time without notice. Actual dimensions and performance data given herein may vary due to manufacturing tolerances.



1900 NORTH STREET • MARYSVILLE, KS 66508 • (800)428.5655 • www.landoll.com/mhp

