

L5C25 / L5C30



LANDOLL CORPORATION
MATERIAL HANDLING DIVISION

800-428-5655 • www.landoll.com/mhp



Landoll Stand Up Ride, Co

The LSC is a 3 wheel stand-up ride, compact, rear entry front loader, with a single poly rear drive/steer tire and poly front load tires. Its short turning radius, high visibility mast and compact design makes stacking and dock work easy and efficient. The low step height provides easy access on and off the truck for order picking and load checking. Ergonomically designed operator controls make operation safe, convenient and comfortable for any operator.

STANDARD FEATURES

- Two or Three Stage High Visibility Mast
- 2,500 lb. (1,136 kg) or 3,000 lb. (1,364 kg) Capacity
- Multi Function Control for Lift/Lower, Direction and Speed Control
- Single 24 Volt AC Traction and DC Pump Controller
- Tiller Controlled Hydraulic Power Steering
- Cantilevered Overhead Guard
- Thick Cushioned Rubber Floor Mat
- Horn, Battery Discharge Indicator and Hour Meter
- Left Foot Operated Electric Deadman Parking Brake
- Right Foot Operated Hydraulic Front Wheel Service Brakes
- 10" x 5" (250mm x 127mm) Smooth Poly Rear Drive/Steer Tire
- 14" x 5" (356mm x 127mm) Smooth Poly Front Load Tires
- Easily Removable Covers for Access to all Major Components
- Easily Replaceable Hydraulic Filter Element
- Battery Compartment can be Set Up for Left or Right Removal
- Battery Compartment Slide Strips for Easy Side Removal
- 36" (914mm) High Load Backrest and 34" (864mm) Wide Fork Carriage
- 42" (1067mm) Tapered Forks
- 3 Spool Hydraulic Control Valve
- Meets ANSI B56.1 Requirements



Low Step Height Operator Rear Entry



Ergonomic Operator Control Console

OPTIONAL FEATURES

- LED Headlights with Dash Switch
- LED Low Profile Strobe (Increases Overhead Guard Height 1" (25mm))
- Bolt-on Third Forward Overhead Guard Post
- Removable Swing Out Rear Door
- Rear Operator's Compartment Floor Extension
- Backup Alarm, Beeping
- 36" (914mm), 40" (1,000mm) or 48" (1,200mm) Forks
- Integral Sideshifter with 8" (203mm) Stroke
- Integral Side Shifting Fork Positioner
- Freezer Conditioning for -22° F (-30° C)
- Rear Locking Safety Belt Restraint
- Fire Extinguisher
- 48" (1,200mm) High Load Backrest

Compact Electric Lift Truck



TECHNICAL & DIMENSION DATA

MODEL			LSC25	LSC30
Capacity		At 24" (600mm) Load Center	lbs/kg	2,500 / 1,136
Truck weight			in/mm	6,750 / 3,068
Travel speed		Loaded	mph/kph	6 / 9.7
		Unloaded	mph/kph	7 / 11.3
Lift Speed		Loaded	fpm/mpm	35 / 11
		Unloaded	fpm/mpm	62 / 19
Lowering Speed		Loaded	fpm/mpm	90 / 27.4
		Unloaded	fpm/mpm	80 / 24.3
Mast Tilt		Back/Fwd - Simplex Mast	degrees	8 / 5
		Back/Fwd - Triplex Mast	degrees	5 / 5
Lost Load Center	E		in/cm	10.7 / 27
Wheelbase	F	Mast Vertical	in/cm	34.6 / 88
Rear Overhang	G			14.4 / 37
Overall Length to Fork Face	H	Mast Vertical	in/cm	59.7 / 152
Underclearance	I		in/cm	3 / 7.7
Operator Floor Height	J		in/cm	10.5 / 27
Overhead Guard Height	K		in/cm	87 / 221
Overall Width	L		in/cm	37 / 94
Fork Carriage Width	M		in/cm	34 / 86
Fork Length	N		in/cm	42 / 107
Out to Out Fork Spread	O	Minimum/Maximum	in/cm	9.4-32.5 / 24-83
Outside Turning Radius	P		in/cm	50 / 127
Right Angle Stacking Aisle	Q	w/48" L x 40" W (1200mm x 1000mm) Load	in/cm	114 / 290
Battery Compartment Height	R	Floor to Top of Slider Bars	in/cm	15.5 / 39
Equal Intersecting Aisle	S	Mast Vertical with 36" (914mm) Forks	in/cm	57.4 / 146
Gradeability		Loaded/Unloaded	%	7 / 12
Hydraulic Motor Rating		Continuous Duty Rating	type/kwh	DC/3
Traction Motor Rating		Continuous Duty Rating	type/kwh	AC/4 KWH
Traction Control Type		Induction		AC
Hydraulic Control Type		Series		DC
Wheel Sizes		Front 2 Each Poly-Dia x face	in/cm	14x5 / 36x13
		Rear 1 Each Poly-Dia x face	in/cm	10x5 / 25x13

MAST DIMENSIONS

Max. Fork Height (A)		Lowered Height (B)		Free Lift Height (C)		** Max. Overall Height (D)	
Inches	Meters	Inches	Meters	Inches	Meters	Inches	Meters
Simplex (2 Stage) Mast (Minimum Free Lift)216							
130	3.30	85	2.16	5.5	0.14	166	4.22
Triplex (3 Stage) Mast (*Maximum Free Lift)							
170	4.32	77	1.96	41	1.04	206	5.23
198	5.03	87	2.21	51	1.30	234	5.94
216	5.49	95	2.41	59	1.50	252	6.40
* Free Lift Based on 36" (914mm) High Load Backrest							
** Max Overall Height Based on 36" (914mm) Load Backrest							
Dimensions Based on 3" (76.2mm) Mast Underclearance							

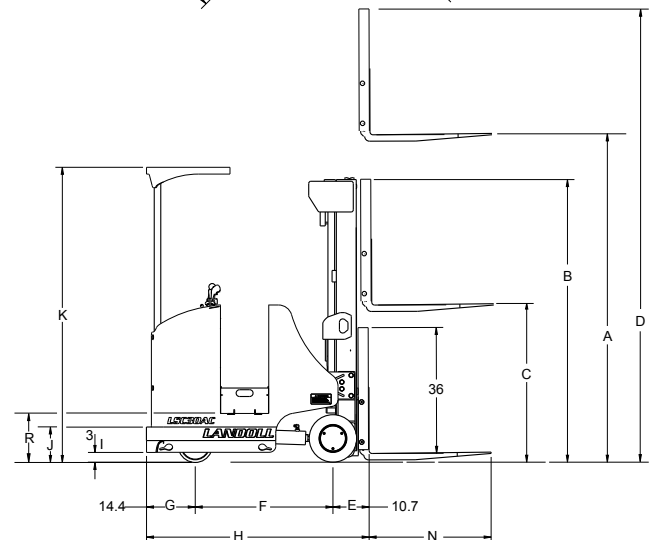
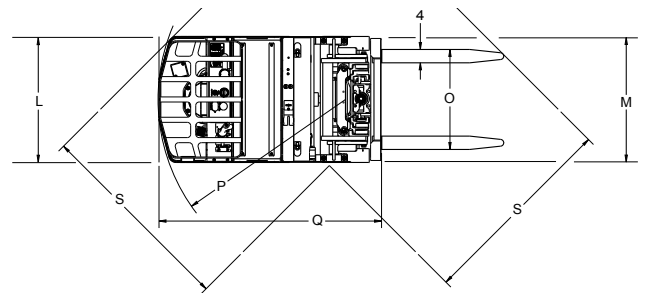

RECOMMENDED BATTERIES

Battery compartment inside clear dimensions: 36.5"x13.6"x31" (92.7cm x 34.5cm x 78.7 cm)						
Battery	Amp Hour	X Dim in/cm	Y Dim in/cm	Z Dim in/cm	Wt. lbs/kg	Cover
12-125-15	875	35.44/90	13/33	31/79	1561/709	Yes
12-125-13	750	30.94/79	13/33	31/79	1365/620	Yes
12-100-13	600	30.94/79	13/33	26.25/67	1118/508	Yes
Leads are required at position B, 20" (51 cm) long, SB350 AMP Red Connector						

Landoll LSC's simplicity and designed in maintainability make the cost of ownership much lower than comparable forklifts. A front cover provides easy access to the hydraulic tank and dipstick, and the modular hydraulic motor/pump assembly. A rear cover provides access to the drive system, including AC traction and hydraulic controls, fuses and all major components including the hydraulic valve, master cylinder and electric brake.



Rear Cover Removed



Front Cover Removed



1900 North Street • Marysville, KS 66508
800-428-5655
www.landoll.com/mhp

