

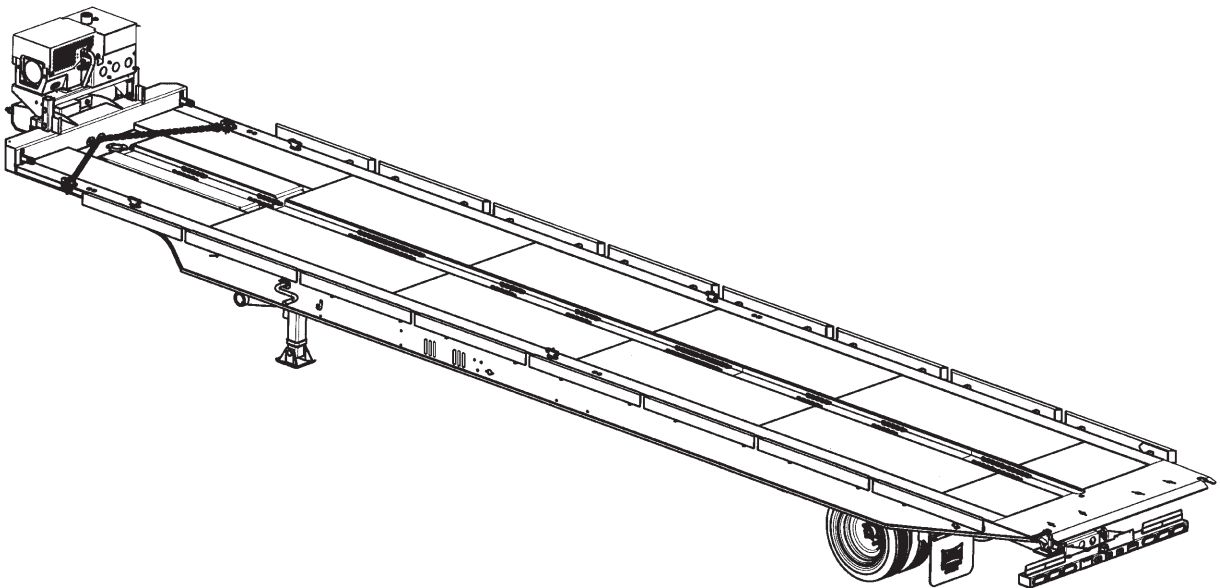

**MODEL 340
SEMITRAILER
OPERATOR'S MANUAL**



**1900 North Street
Marysville, KS 66508
(785)562-5381**

**MODEL 340
SEMITRAILER
OPERATOR'S MANUAL**

PURCHASED FROM: _____ **DATE** ____ / ____ / ____

ADDRESS: _____

PHONE NO.: _____ **SERIAL NO.:** _____

REPORTING SAFETY DEFECTS

If you believe that your vehicle has a defect which could cause a crash or could cause injury or death, you should immediately inform the National Highway Traffic Safety Administration (NHTSA) in addition to notifying Landoll Manufacturing.

If NHTSA receives similar complaints, it may open an investigation, and if it finds that a safety defect exists in a group of vehicles, it may order a recall and remedy campaign. However, NHTSA cannot become involved in individual problems between you, your dealer, or Landoll Manufacturing.

To contact NHTSA, you may either call the Auto Safety Hotline toll-free at 1-800-424-9393 (or 366-0123 in Washington, D.C. area) or write to: NHTSA, U.S. Department of Transportation, Washington, D.C. 20590. You can also obtain other information about motor vehicle safety from the Hotline.

In the event of a defect or problem with your LANDOLL equipment, please notify LANDOLL CORPORATION:

**LANDOLL CORPORATION
SALES AND SERVICE
1900 NORTH STREET
MARYSVILLE, KANSAS 66508**

OR PHONE:

1-800-HAULLOLL

(1-800-428-5655)

FAX NO.: (785)562-3240

FOR REPLACEMENT PARTS:

(785)562-4650

1-800-423-4320

FAX NO.: (785) 562-4654

TABLE OF CONTENTS

| SECTION NO. | DESCRIPTION | PAGE NO. |
|-------------|---|----------|
| 1 | INTRODUCTION | 1-1 |
| 2 | STANDARD SPECIFICATIONS. | 2-1 |
| 3 | OPERATING INSTRUCTIONS. | 3-1 |
| 3-1 | PRE-COUPLING OF SEMITRAILER AND TRACTOR | 3-2 |
| 3-2 | COUPLING OF THE TRACTOR TO THE SEMITRAILER | 3-2 |
| 3-3 | CONNECTING TRACTOR SERVICES TO THE SEMITRAILER. | 3-3 |
| 3-4 | TRACTOR AND SEMITRAILER CHECK-OUT | 3-3 |
| 3-5 | TOWING THE SEMITRAILER. | 3-4 |
| 3-6 | PARKING THE SEMITRAILER | 3-5 |
| 3-7 | UNCOUPLING TRACTOR FROM SEMITRAILER | 3-5 |
| 3-8 | TRAILER TILT LEVER. | 3-6 |
| 3-9 | AXLE CONTROL LEVER. | 3-6 |
| 3-10 | GEARBOX CONTROLS | 3-6 |
| 3-11 | LOADING PROCEDURE | 3-7 |
| 3-12 | UNLOADING THE TRAILER. | 3-12 |
| 3-13 | AUXILIARY HYDRAULIC POWER ENGINE OPERATION | 3-14 |
| 3-14 | BULKHEADS. | 3-15 |
| 3-15 | REAR IMPACT GUARD SYSTEM. | 3-15 |
| 3-16 | ANTI-LOCK BRAKE SYSTEM (ABS) | 3-17 |
| 3-17 | COLD WEATHER OPERATION | 3-18 |
| 3-18 | HOT WEATHER OPERATION | 3-18 |
| 4 | MAINTENANCE AND LUBRICATION | 4-1 |
| 4-1 | MAINTENANCE SCHEDULE | 4-1 |
| 4-2 | MAINTENANCE PROCEDURES. | 4-5 |
| 4-3 | HITCH, FRAME, AND DECK | 4-5 |
| 4-4 | HYDRAULIC SYSTEM | 4-9 |
| 4-5 | ELECTRICAL SYSTEM | 4-9 |
| 4-6 | SUSPENSION MAINTENANCE. | 4-10 |
| 4-7 | ALIGNMENT | 4-11 |
| 4-8 | BRAKE SYSTEM MAINTENANCE | 4-14 |
| 4-9 | HUB AND DRUM MAINTENANCE | 4-19 |
| 4-10 | WHEEL BEARING LUBRICATION AND ADJUSTMENT. | 4-21 |
| 4-11 | TIRE MAINTENANCE. | 4-22 |
| 4-12 | GEARBOX MAINTENANCE | 4-24 |
| 4-13 | HYDRAULIC ENGINE PACKAGE | 4-25 |
| 5 | TROUBLESHOOTING GUIDE. | 5-1 |

SAFETY PRECAUTIONS



THIS IS THE SAFETY ALERT SYMBOL. IT IS USED TO ALERT YOU TO POTENTIAL INJURY HAZARDS. OBEY ALL SAFETY MESSAGES THAT FOLLOW THIS SYMBOL TO AVOID POSSIBLE INJURY OR DEATH.

DANGER

DANGER INDICATES AN IMMINENTLY HAZARDOUS SITUATION WHICH, IF NOT AVOIDED, WILL RESULT IN DEATH OR SERIOUS INJURY.

WARNING

WARNING INDICATES A POTENTIALLY HAZARDOUS SITUATION WHICH, IF NOT AVOIDED, COULD RESULT IN DEATH OR SERIOUS INJURY.

CAUTION

CAUTION INDICATES A POTENTIALLY HAZARDOUS SITUATION WHICH, IF NOT AVOIDED, MAY RESULT IN MINOR OR MODERATE INJURY.

CAUTION

CAUTION USED WITHOUT THE SAFETY ALERT SYMBOL INDICATES A POTENTIALLY HAZARDOUS SITUATION WHICH, IF NOT AVOIDED, MAY RESULT IN PROPERTY DAMAGE.



This manual provides operating, servicing, and maintenance instructions, with detailed parts lists for Model 340 semitrailer, manufactured by Landoll Corporation, Marysville, Kansas 66508.

- SECTION 1** gives basic instructions on the use of this manual.
- SECTION 2** gives specifications for the semitrailer, including measurements and component specifications. A Standard Bolt Torque Table is provided to give guidelines for bolt torques to be used when servicing this product.
- SECTION 3** gives instructions for the proper operation of the equipment.
- SECTION 4** gives general maintenance procedures, a maintenance schedule, and a lubrication schedule. Improper maintenance will void your warranty.

IF YOU HAVE ANY QUESTIONS CONTACT:

**LANDOLL CORPORATION
1900 NORTH STREET
MARYSVILLE, KANSAS 66508
or phone:
(785) 562-5381 or
(800) 428-5655
or FAX:
(785) 562-4893**

- SECTION 5** is a troubleshooting guide to aid in diagnosing and solving problems with the semitrailer.
- PARTS LIST** is a separate manual showing the various assemblies, subassemblies, and systems. Refer to that manual when ordering Landoll replacement parts. Order parts from your Landoll dealer.
- WARRANTY** The Warranty Registration form is located with the product documents. Fill it out and mail it within 15 days of purchase. The Warranty is printed inside the front cover.

NOTE: IMPROPER ASSEMBLY, MODIFICATION, OR MAINTENANCE OF YOUR LANDOLL MACHINE CAN VOID YOUR WARRANTY.

- COMMENTS** Address comments or questions regarding this publication to:

**LANDOLL CORPORATION
1900 NORTH STREET
MARYSVILLE, KANSAS 66508
ATTENTION: PUBLISHING -DEPT. 55**

STANDARD SPECIFICATIONS

CAPACITY*:

SINGLE AXLE 11,800 LB. DISTR. - 10,000 LB. in 10 FT.

KING PIN SETTING: 18"
. 43" SETBACK

UNDERCARRIAGE TRAVEL: 10'-6"

STANDARD LOAD ANGLE: 12°

HYDRAULIC HOOKUP:

QUICK COUPLERS FLAT FACE 3/4" BODY SIZE
MAXIMUM OPERATING PRESSURE 2500 PSI
OPERATING FLOW 17 GPM

ELECTRICAL HOOKUP: 7-WAY CONNECTOR

AIR HOOKUP: COLOR CODED GLAD HANDS

SPECIFIC BOLT TORQUES

AIR RIDE SUSPENSION:

EQUALIZER BEAM PIVOT AND ADAPTER BOLTS
DESIGNATED W/ NEWAY ON BOLT HEAD 800 FT.-LBS.
DESIGNATED W/ HOLLAND NEWAY ON BOLT HEAD 550 FT.-LBS.
SHOCK ABSORBER MOUNTING 150 FT.-LBS.
AIR SPRING MOUNTING: 1/2" 35 FT.-LBS.
3/4" 35 FT.-LBS.

FOUR SPRING SUSPENSION:

AXLE CLAMP U-BOLTS 300 FT.-LBS.
EQUALIZER BEAM PIVOT BOLT 480-500 FT.-LBS.
TORQUE ARM BOLT 250 FT.-LBS.
TORQUE ARM CLAMP NUTS 60 FT.-LBS.

WHEEL FASTENERS - ALL MODELS:

OUTER SPINDLE NUTS 250-400 FT.-LBS.
PILOT WHEEL NUTS 450-500 FT.-LBS.

* CAPACITY RATINGS ARE FRAME CAPACITIES ONLY. ACTUAL LOAD CAPACITIES MAY BE RESTRICTED BY FACTORS SUCH AS GROSS AXLE WEIGHT RATINGS (GAWR) OR STATE AND FEDERAL REGULATIONS.

**LANDOLL CORPORATION
GENERAL TORQUE SPECIFICATIONS (REV. 4/97)**

THIS CHART PROVIDES TIGHTENING TORQUES FOR GENERAL PURPOSE APPLICATIONS WHEN SPECIAL TORQUES ARE NOT SPECIFIED ON PROCESS OR DRAWING.
 ASSEMBLY TORQUES APPLY TO PLATED NUTS AND CAPSCREWS ASSEMBLED WITHOUT SUPPLEMENTAL LUBRICATION (AS RECEIVED CONDITION). THEY DO NOT APPLY IF SPECIAL GRAPHITE MOLY-DISULFIDE OR OTHER EXTREME PRESSURE LUBRICANTS ARE USED.
 WHEN FASTENERS ARE DRY (SOLVENT CLEANED), ADD 33% TO AS RECEIVED CONDITION TORQUE.
 BOLT HEAD IDENTIFICATION MARKS INDICATE GRADE AND MAY VARY FROM MANUFACTURER TO MANUFACTURER.
 THICK NUTS MUST BE USED ON GRADE 8 CAPSCREWS.
 USE VALUE IN [] IF USING PREVAILING TORQUE NUTS.
TORQUE IS SPECIFIED IN FOOT POUNDS

| UNC Size | SAE Grade 2 | | SAE Grade 5 | | SAE Grade 8 | | UNF Size | SAE Grade 2 | | SAE Grade 5 | | SAE Grade 8 | |
|----------|-------------|-------|-------------|--------|-------------|--------|----------|-------------|-------|-------------|--------|-------------|--------|
| 1/4-20 | 4 | [5] | 6 | [7] | 9 | [11] | 1/4-28 | 5 | [6] | 7 | [9] | 10 | [12] |
| 5/16-18 | 8 | [10] | 13 | [16] | 18 | [22] | 5/16-24 | 9 | [11] | 14 | [17] | 20 | [25] |
| 3/8-16 | 15 | [19] | 23 | [29] | 35 | [43] | 3/8-24 | 17 | [21] | 25 | [31] | 35 | [44] |
| 7/16-14 | 24 | [30] | 35 | [43] | 55 | [62] | 7/16-20 | 27 | [34] | 40 | [50] | 60 | [75] |
| 1/2-13 | 35 | [43] | 55 | [62] | 80 | [100] | 1/2-20 | 40 | [50] | 65 | [81] | 90 | [112] |
| 9/16-12 | 55 | [62] | 80 | [100] | 110 | [137] | 9/16-18 | 60 | [75] | 90 | [112] | 130 | [162] |
| 5/8-11 | 75 | [94] | 110 | [137] | 170 | [212] | 5/8-18 | 85 | [106] | 130 | [162] | 180 | [225] |
| 3/4-10 | 130 | [162] | 200 | [250] | 280 | [350] | 3/4-16 | 150 | [188] | 220 | [275] | 320 | [400] |
| 7/8-9 | 125 | [156] | 320 | [400] | 460 | [575] | 7/8-14 | 140 | [175] | 360 | [450] | 500 | [625] |
| 1-8 | 190 | [237] | 408 | [506] | 680 | [850] | 1-14 | 210 | [263] | 540 | [675] | 760 | [950] |
| 1-1/8-7 | 270 | [337] | 600 | [750] | 960 | [1200] | 1-1/8-12 | 300 | [375] | 660 | [825] | 1080 | [1350] |
| 1-1/4-7 | 380 | [475] | 840 | [1050] | 1426 | [1782] | 1-1/4-12 | 420 | [525] | 920 | [1150] | 1500 | [1875] |
| 1-3/8-6 | 490 | [612] | 110 | [1375] | 1780 | [2225] | 1-3/8-12 | 560 | [700] | 1260 | [1575] | 2010 | [2512] |
| 1/1-2-6 | 650 | [812] | 1460 | [1825] | 2360 | [2950] | 1/1-2-12 | 730 | [912] | 1640 | [2050] | 2660 | [3325] |

METRIC

COARSE THREAD METRIC CLASS 10.9 FASTENERS AND CLASS 10.0 NUTS AND THROUGH HARDENED FLAT WASHERS, PHOSPHATE COATED, ROCKWELL "C" 38-45.
 USE VALUE IN [] IF USING PREVAILING TORQUE NUTS.

| Nominal Thread Diameter mm | Standard Torque | | Nominal Thread Diameter mm | Standard Torque | | | | | |
|----------------------------|-----------------|-------------|----------------------------|-----------------|-------------|------|--------|------|--------|
| | Newton-Meters | Foot-Pounds | | Newton-Meters | Foot-Pounds | | | | |
| 6 | 10 | [14] | 7 | [10] | 20 | 385 | [450] | 290 | [335] |
| 7 | 16 | [22] | 12 | [16] | 24 | 670 | [775] | 500 | [625] |
| 8 | 23 | [32] | 17 | [24] | 27 | 980 | [1105] | 730 | [825] |
| 10 | 46 | [60] | 34 | [47] | 30 | 1330 | [1470] | 990 | [1090] |
| 12 | 80 | [101] | 60 | [75] | 33 | 1790 | [1950] | 1340 | [1450] |
| 14 | 125 | [155] | 90 | [115] | 36 | 2325 | [2515] | 1730 | [1870] |
| 16 | 200 | [240] | 150 | [180] | 39 | 3010 | [3210] | 2240 | [2380] |
| 18 | 275 | [330] | 205 | [245] | | | | | |

Table 2-1 General Torque Specifications

**LANDOLL CORPORATION
HYDRAULIC FITTING TORQUE SPECIFICATIONS
37° JIC, ORS, & ORB (REV. 10/97)**

THIS CHART PROVIDES TIGHTENING TORQUES FOR HYDRAULIC FITTING APPLICATIONS WHEN SPECIAL TORQUES ARE NOT SPECIFIED ON PROCESS OR DRAWING.
 ASSEMBLY TORQUES APPLY TO PLATED CARBON STEEL AND STAINLESS STEEL FITTINGS ASSEMBLED WITHOUT SUPPLEMENTAL LUBRICATION (AS RECEIVED CONDITION). THEY DO NOT APPLY IF SPECIAL GRAPHITE MOLY-DISULFIDE OR OTHER EXTREME PRESSURE LUBRICANTS ARE USED.
 BRASS FITTINGS AND ADAPTERS - 65% OF THE TORQUE VALUE FOR STEEL. STAINLESS STEEL, ALUMINUM AND MONEL - THREADS ARE TO BE LUBRICATED.
TORQUE IS SPECIFIED IN FOOT POUNDS

PARKER BRAND FITTINGS

| Dash Size | 37 Degree JIC | O-Ring (ORS) | O-Ring Boss (ORB) |
|-----------|---------------|--------------|-------------------|
| -4 | 11-13 | 15-17 | 13-15 |
| -5 | 14-16 | — | 21-23 |
| -6 | 20-22 | 34-36 | 25-29 |
| -8 | 43-47 | 58-62 | 40-44 |
| -10 | 55-65 | 100-110 | 57.5-62.5 |
| -12 | 80-90 | 134-146 | 75-85 |
| -16 | 115-125 | 202-218 | 109-121 |
| -20 | 160-180 | 248-272 | 213-237 |
| -24 | 185-215 | 303-327 | 238-262 |
| -32 | 250-290 | — | 310-340 |

**LANDOLL CORPORATION
HYDRAULIC FITTING TORQUE SPECIFICATIONS
37° JIC, ORS & ORB (REV. 10/97)**

THIS CHART PROVIDES TIGHTENING TORQUES FOR HYDRAULIC FITTING APPLICATIONS WHEN SPECIAL TORQUES ARE NOT SPECIFIED ON PROCESS OR DRAWING.
 ASSEMBLY TORQUES APPLY TO PLATED CARBON STEEL AND STAINLESS STEEL FITTINGS ASSEMBLED WITHOUT SUPPLEMENTAL LUBRICATION (AS RECEIVED CONDITION). THEY DO NOT APPLY IF SPECIAL GRAPHITE MOLY-DISULFIDE OR OTHER EXTREME PRESSURE LUBRICANTS ARE USED.
 BRASS FITTINGS AND ADAPTERS - 65% OF THE TORQUE VALUE FOR STEEL.
TORQUE IS SPECIFIED IN FOOT POUNDS.



AEROQUIP BRAND FITTINGS

| Dash Size | 37 Degree JIC | O-Ring (ORS) | O-Ring Boss (ORB) |
|-----------|---------------|--------------|-------------------|
| -4 | 11-12 | 10-12 | 14-16 |
| -5 | 15-16 | — | 18-20 |
| -6 | 18-20 | 18-20 | 24-26 |
| -8 | 38-42 | 32-35 | 50-60 |
| -10 | 57-62 | 46-50 | 72-80 |
| -12 | 79-87 | 65-70 | 125-135 |
| -14 | — | — | 160-180 |
| -16 | 108-113 | 92-100 | 200-220 |
| -20 | 127-133 | 125-140 | 210-280 |
| -24 | 158-167 | 150-165 | 270-360 |
| -32 | 245-258 | — | — |

Table 2-2 Hydraulic Fitting Torque Specifications

This section supplies information for operation of the trailer. It describes and locates controls and gives general operation procedures. Read all instructions, warnings, cautions and danger notes before attempting to operate the trailer. Operators must have proper training before operating the semitrailer.

A hydraulic pump must be coupled to the trailer hydraulic system, or the optional hydraulic engine package started, before using hydraulic controls.



| |
|---|
|  WARNING |
| DO NOT OPERATE THE SEMITRAILER WITH ANY KNOWN FAULT THAT MIGHT ENDANGER THE OCCUPANTS, NEARBY WORKERS, OTHER TRAFFIC, THE LOAD, OR THE EQUIPMENT. |
|  WARNING |
| DO NOT OPERATE THE SEMITRAILER UNTIL YOU HAVE READ THE OPERATOR'S MANUAL AND COMPLETELY UNDERSTAND THE PROPER USE AND FUNCTION OF ALL CONTROLS. IMPROPER USE CAN CAUSE PERSONAL INJURY, DAMAGE TO YOUR SEMITRAILER AND CARGO, AND CAUSE TIME-CONSUMING BREAKDOWNS. |

3-0.1 Air Brake System

The air brake system of the trailer is operated from the towing vehicle after coupling. The towing vehicle's air system must be coupled to the trailer and charged to 90 psi minimum before the brakes can adequately function.

3-0.2 Anti-Lock Brake System (ABS)

The Anti-Lock Brake System of the semitrailer is constantly powered by the auxiliary (blue) circuit of the seven way electrical connector, with backup power from the stop lamp (red) circuit, and ground through the white wire. It is necessary that the blue circuit is hot when the tractor key switch is on. The blue circuit on the trailer may also not be used to power any additional auxiliary devices while the semitrailer is moving forward. If a fault exists in the ABS, normal braking will occur, but the wheels may lock. Service the ABS as soon as possible.

| |
|--|
|  CAUTION |
| THE AUXILIARY (BLUE) CIRCUIT IS FOR POWERING THE SEMITRAILER ABS. THIS CIRCUIT MUST BE HOT WHEN THE TRACTOR KEY SWITCH IS ON. NO OTHER ELECTRICAL DEVICES MAY BE POWERED BY THIS CIRCUIT WHILE THE SEMITRAILER IS MOVING FORWARD. |
|  CAUTION |
| IF A FAULT EXISTS IN THE SEMITRAILER ABS, NORMAL BRAKING WILL OCCUR, BUT WHEELS MAY LOCK. SERVICE THE ABS AS SOON AS POSSIBLE. |

3-1 PRE-COUPLING OF SEMITRAILER AND TRACTOR

3-1.1 Slowly back the tractor up to the front end of the semitrailer so the kingpin of the semitrailer is centered between the tractor fifth wheel jaws. Stop the tractor several inches ahead of the semitrailer. Set tractor parking brake.

3-1.2 The king pin plate should be the same height as, or slightly lower than, the latch area of the fifth wheel plate of the tractor. If necessary, connect the tractor hydraulic lines or start the trailer hydraulic power engine. Use the **TRAILER TILT (5TH WHEEL)** lever (See **Figure 3-2**) to raise or lower the kingpin plate sufficiently to allow proper coupling. Drain all air and moisture from the tractor air brake system in accordance with the tractor manufacturer's instructions.

3-1.3 Connect the service and emergency air hoses of the tractor to their respective gladhand on the front of the semitrailer. The tractor's air hose couplings are then attached and locked to the appropriate gladhands; the **red emergency line** to the gladhand with the "**EMERGENCY**" tag, and the **blue service line** to the gladhand with the "**SERVICE**" tag (See **Figure 3-1**). Chock the semitrailer wheels before activating the semitrailer air supply valve in the tractor. Set the semitrailer brakes.

3-1.4 Check the air brake operations of the semitrailer as follows:

- a. Apply brakes and inspect brake action on all wheels for prompt application.
- b. Release brakes. All brakes should release immediately. Air pressure should discharge quickly from the relay emergency valve.
- c. Disconnect the emergency air line from the semitrailer gladhand. Semitrailer brakes should promptly set.
- d. Re-connect the emergency air line to the semitrailer and activate the semitrailer air supply valve. The semitrailer brakes should set.

3-2 COUPLING OF THE TRACTOR TO THE SEMITRAILER

DANGER

KEEP ALL PERSONNEL CLEAR OF FRONT, REAR, AND SIDES OF TRACTOR AND SEMITRAILER DURING COUPLING, COMPONENT OPERATIONS, AND UNCOUPLING. FAILURE TO STAY CLEAR CAN RESULT IN SERIOUS PERSONAL INJURY OR DEATH.

3-2.1 Verify the semitrailer wheels are chocked and brakes function properly.

3-2.2 Make sure the tractor's fifth wheel coupler is open.

3-2.3 Slowly back the tractor so its fifth wheel contacts the front of the kingpin plate on the semitrailer and slips under it. Continue backing until the fifth wheel coupler locks onto the semitrailer kingpin.

3-2.4 Try to pull the tractor forward a few inches to verify the vehicle coupling is secure. If the tractor disconnects from the semitrailer: locate the source of the coupling failure; repair before continuing; and repeat **Steps 3-2.3 and 3-2.4**.

CAUTION

PUSHING SEMITRAILER BACKWARDS CAN DAMAGE LANDING GEAR.

3-2.5 Check that the tractor couples securely to the semitrailer before setting tractor and semitrailer parking brakes.

IMPORTANT

KEEP BRAKES ENGAGED FOR REMAINDER OF COUPLING, CHECK-OUT, AND PARKING.

3-3 CONNECTING TRACTOR SERVICES TO THE SEMITRAILER

3-3.1 Connect the tractor 7-way electrical plug to the electrical receptacle on the front of the semitrailer (See Figure 3-1).

IMPORTANT

THE KEY ON THE PLUG AND THE KEYWAY IN THE SOCKET MUST BE PROPERLY ALIGNED BEFORE INSERTING THE PLUG INTO THE SEMITRAILER SOCKET.

3-3.2 If you have not already done so, connect the tractor hydraulic lines to the semitrailer, unless your semitrailer is equipped with the auxiliary hydraulic power engine package.

IMPORTANT

SOME OIL MAY NEED TO BE REMOVED FROM THE TRACTOR RESERVOIR TO ALLOW ROOM FOR 7 GALLONS OF ADDITIONAL OIL DISPLACED FROM THE SEMITRAILER HYDRAULIC SYSTEM.

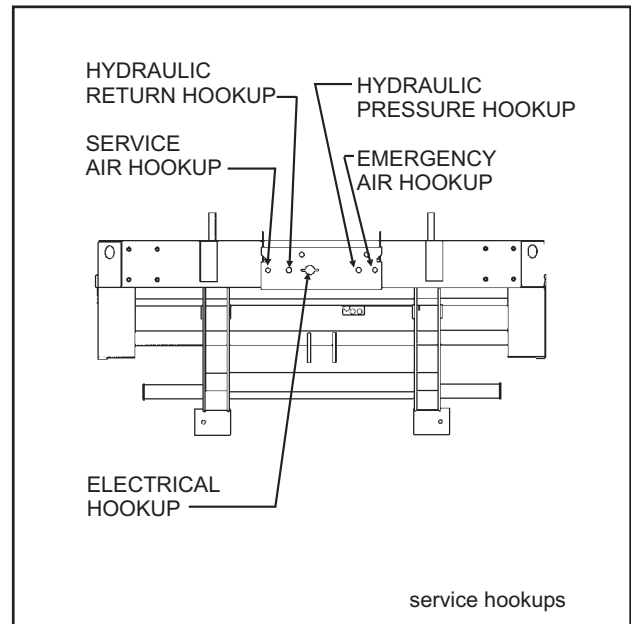

Figure 3-1 Service Hookups (Front View)

3-4 TRACTOR AND SEMITRAILER CHECK-OUT

3-4.1 While hydraulic power is operating, raise the front end of the semitrailer with the **TRAILER TILT (5TH WHEEL) lever** (See Figure 3-2) until weight is off the landing gear. Raise landing gear. Secure each leg with a park stand retaining pin in fully retracted position before transporting.

⚠ WARNING

LANDING GEAR LEGS MUST BE FULLY RETRACTED AND SECURED WITH PINS BEFORE OPERATING OR MOVING SEMITRAILER.

3-4.2 Lower the front end with the **TRAILER TILT (5TH WHEEL) lever** until the semitrailer is fully lowered. Hold lever in the down position until hydraulic system works against the bottomed out hydraulic tilt cylinders.

3-4.3 Verify that the traveling undercarriage is completely slid back to transport position. Shut off hydraulic power.

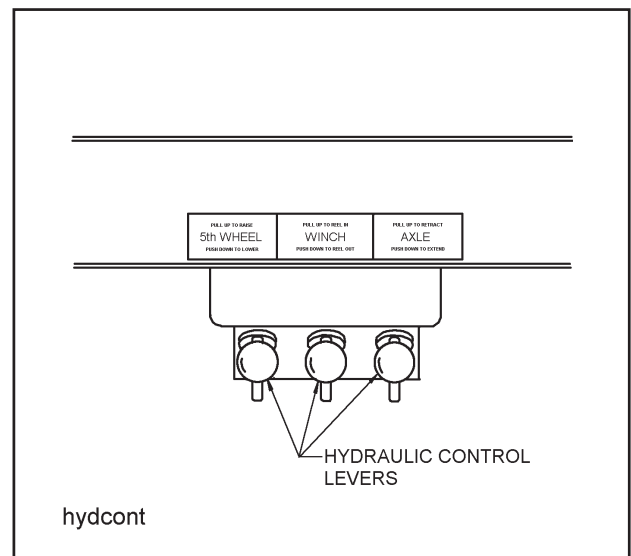

Figure 3-2 Hydraulic Control Levers

- 3-4.4** Check the operation of all lights and signals on the semitrailer for proper response to switch positions (stop, right turn, left turn and clearance).
- 3-4.5** Check that tire inflation matches the pressure listed on the tire.
- 3-4.6** Check tractor/semitrailer combination for air leaks. If air leakage is found, repair the defect before transporting.

- 3-4.7** Check that the oil in each hub is at the proper level and free from contamination. If hubs contain water, dirt, or other foreign matter, clean them before transporting.
- 3-4.8** Check tractor air pressure. Pressure must not fall below 65 psi, even after activating brakes a couple of times. Set parking brake and carefully remove all wheel chocks. Set emergency brake and try pulling forward. The semitrailer wheels must not rotate. If semitrailer brakes do not apply, do not transport until defect, or defects, are repaired.

3-5 TOWING THE SEMITRAILER

- 3-5.1** Driving the tractor with the semitrailer coupled behind requires constant attention to the overall length. Turning, passing, accelerating, braking, stopping, and back-up require special considerations. When executing steep grades or turning tight curves, the semitrailer must not be allowed to push the tractor, or jackknifing may result. Application of the semitrailer brakes to keep the semitrailer in tow will help prevent this situation. To assure control, brake before descending a hill or attempting a curve.
- 3-5.2** Make a moving test of the semitrailer brakes at low and medium speeds **before** traveling at highway speed.
- a.** The Anti-Lock Brake System (ABS) warning lamp mounted at left rear side of the trailer should come on when power is supplied to the ABS by turning the tractor keyswitch on. The warning lamp should go off once the trailer exceeds 4 mph. If the warning lamp does not go off, a fault exists in the trailer ABS. Once the vehicle speed exceeds 4 mph, the light should remain off unless a fault occurs or the keyswitch is turned off, then on again.

- 3-5.3** Monitor the air pressure gauge on the dash of the tractor. Pressure should not fall below 90 psi at any time.

CAUTION

WHEN OPERATING TRAILER, DO NOT BACK OVER CURB. THIS WILL CAUSE SEVERE DAMAGE TO UNDERCARRIAGE AND UNDERCARRIAGE CYLINDER.

- 3-5.4** The semitrailer wheels track to the inside of the tractor during turns. Thus, turning corners requires a wide swing to prevent “curb hopping”, and to allow the semitrailer wheels to clear any obstacle on the inside of the corner.
- 3-5.5** To stop, use a gradual and smooth application of brakes. If grabbing occurs, apply less pressure. Grabbing brakes are not efficient.

DANGER

ALWAYS CHECK BEHIND AND UNDER THE TRACTOR AND SEMITRAILER FOR PERSONS OR OBJECTS BEFORE MOVING. FAILURE TO CHECK CAN LEAD TO SERIOUS PERSONAL INJURY, DEATH, OR DAMAGE TO PROPERTY.

- 3-5.6** Backing should be done with care. Tail overhang, semitrailer length, and allowable space must be taken into consideration.

3-6 PARKING THE SEMITRAILER

- 3-6.1 Position tractor/trailer rig on a level, solid surface.
- 3-6.2 Set the **PARKING BRAKE**, not the **semitrailer emergency hand brake**, and check for proper brake holding.
- 3-6.3 Chock wheels.
- 3-6.4 Check for any air leaks in lines, relay valve, brake pods, or any other air system component.

WARNING

WHEN LEAVING THE SEMITRAILER UNATTENDED, POSITION ALL HYDRAULIC CONTROLS TO THE NEUTRAL OR "OFF" POSITION AND SHUT OFF THE HYDRAULIC ENGINE POWER SUPPLY, OR DISCONNECT THE TRACTOR HYDRAULIC HOOK-UP.

3-7 UNCOUPLING TRACTOR FROM SEMITRAILER

- 3-7.1 Park the semitrailer according to instructions in **Section 3-6**.
- 3-7.2 Remove retaining pin and lower landing gear to the ground. Hydraulically raise the front end of the semitrailer until the next hole in the landing gear is available. Insert pin through both inner and outer legs of the landing gear. Hydraulically lower semitrailer onto the legs.

WARNING

SECURE EACH LEG WITH PIN BEFORE LEAVING SEMITRAILER UNATTENDED.

- 3-7.3 Pull the tractor fifth wheel plate latch release.
- 3-7.4 Disconnect emergency and service air lines and attach them to the tractor gladhand holders.
- 3-7.5 Disconnect the 7-way cable and hydraulic lines from the semitrailer and store with the tractor.
- 3-7.6 Attempt to pull the tractor forward. If the tractor uncouples, verify that all service lines are disconnected and semitrailer wheels are chocked. If tractor does not disconnect, repeat **Sections 3-7.5 and 3-7.6**.
- 3-7.7 Pull the tractor away from the semitrailer.

3-8 TRAILER TILT (5TH WHEEL) LEVER

The **TRAILER TILT (5TH WHEEL)** lever is located on the driver's side of the semitrailer under the outer frame beam. (See **Figure 3-2**) It has three positions:

UP In this position, the front end of the semitrailer rises to the load position.

CENTER This is the neutral position. The semitrailer stays in its current position.

DOWN In this position, the front end of the semitrailer lowers to the transport position.

3-9 AXLE CONTROL LEVER

The **AXLE CONTROL** lever (See **Figure 3-2**) is the control on the rear with three positions:

UP In this position, the undercarriage slides forward for loading.

CENTER This is the neutral position.

DOWN In this position, the undercarriage slides to the rear. The undercarriage must be in the rear-most position for transport.

3-10 GEARBOX CONTROLS

DANGER

1. THE GEARBOX IS NOT DESIGNED OR INTENDED TO BE USED FOR LIFTING OR MOVING PEOPLE. USING IT THIS WAY CAN CAUSE SERIOUS INJURY OR DEATH.

2. NEVER ATTEMPT TO DISCONNECT THE GEARBOX CHAIN CONNECTOR WHEN THE CHAIN IS UNDER TENSION. LOSS OF LOAD CONTROL, PROPERTY DAMAGE, INJURY OR DEATH CAN RESULT.

3-10.1 The **HYDRAULIC GEARBOX (WINCH) CONTROL** lever (See **Figure 3-2**) is the center lever. It is a three position control:

UP In this position, the chain rotates counter clockwise.

CENTER This is neutral position.

DOWN In this position, the chain rotates clockwise.

3-11 LOADING PROCEDURE

- 3-11.1** Practice all standard industrial safety standards (See Figure 3-4). Do not load any payload that will overload any component of the semitrailer or cause any unsafe condition.
- 3-11.2** Proper operation requires that the undercarriage be pulled fully forward to create lowest low load angle.
- 3-11.3** Park the tractor/semitrailer in a straight line on level even surface. Set the tractor brakes and release the semitrailer brakes (See Figure 3-4).
- 3-11.4** Start operation of hydraulic power system. If the hydraulic engine package is installed, start and warm up engine following engine operating instructions in Section 3-13. (Read engine operator's manual.)
- 3-11.5** Alternate between moving the undercarriage forward and tilting the front of the bed up until the undercarriage is fully forward and the approach plate is on the ground. The weight of the semitrailer bed should rest partly on approach plate and partly on undercarriage. The object is to have the approach plate resting on the ground whenever the center of gravity of the semitrailer and load is behind the rear axle of semitrailer. In loading position, the approach plate should be resting on the ground and the undercarriage fully forward.

CAUTION

DO NOT ALLOW THE BACK SEMITRAILER AXLE TO LEAVE THE GROUND. THIS CAN RESULT IN DAMAGE TO THE SEMITRAILER.

WARNING

IN LOADING OR UNLOADING POSITION, THE APPROACH PLATE SHOULD BE RESTING ON THE GROUND AND THE UNDERCARRIAGE FULLY FORWARD.

WARNING

ALWAYS USE LOW LOAD ANGLE TO LOAD AND UNLOAD POWERED PRODUCTS.

IMPORTANT

SECTIONS 3-11.6 THRU 3-11.12 DESCRIBE GENERAL LOADING PROCEDURES FOR THE SEMITRAILER. SECTIONS AFTER 3-11.12 ARE MORE SPECIFIC OPERATION PROCEDURES FOR LOADING CONTAINERS.

- 3-11.6** Winch or drive the load onto the semitrailer. Insure that the load is steering straight up onto the semitrailer and does not maneuver off the side of the semitrailer. Continue until load center of gravity is just ahead of the axles. The load should never place more weight on the kingpin than on the rear axles during loading and unloading.

CAUTION

MAXIMUM CONCENTRATED LOAD IS 10,000 LBS. IN A 10 FT. AREA FOR A SINGLE AXLE SEMITRAILER.

WARNING

- 1. THE SEMITRAILER MUST BE COUPLED TO A TRACTOR AND THE LANDING GEAR RAISED OFF THE GROUND BEFORE OPERATING.**
- 2. DO NOT EXCEED THE GROSS AXLE WEIGHT RATINGS FOR ANY AXLE ON YOUR VEHICLE. THE COMBINED WEIGHT OF THE SEMITRAILER AND CARGO MUST NOT EXCEED THE GROSS VEHICLE WEIGHT RATING (GVWR) OF THE TRAILER.**



Figure 3-3 Pullout Location

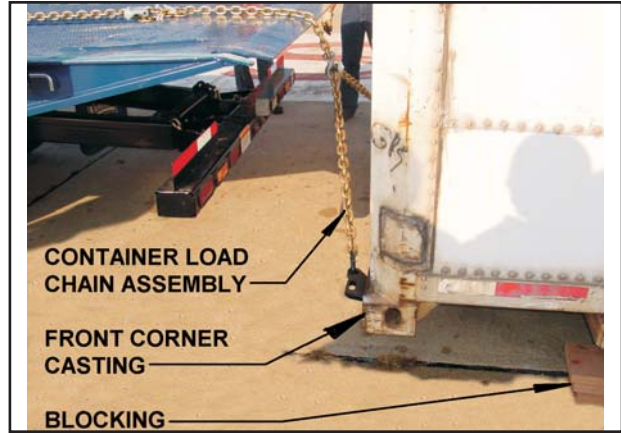

Figure 3-4 Front Corner Castings

⚠ WARNING

THE CENTER OF GRAVITY OF THE LOAD MUST BE IN FRONT OF THE CENTER OF THE UNDERCARRIAGE WHENEVER THE APPROACH PLATE IS NOT SUPPORTED BY THE GROUND. FAILURE TO DO THIS CAN CAUSE THE SEMITRAILER TO TILT BACK RESULTING IN INJURY OR DEATH.

- 3-11.7 If the load center of gravity is not ahead of the rear axle, alternate between tilting the front of the bed up and moving the undercarriage to the rear, until the center of gravity of the semitrailer load is in front of the rear axle. Keep part of the load on the wheels and part on the approach plate. Never move the undercarriage so far to the rear that the approach plate is lifted off the ground during this procedure.
- 3-11.8 When the center of gravity of the semitrailer and load is in front of the rear axle, fully lower the tilt angle.
- 3-11.9 After bed tilt angle is fully lowered, move the undercarriage to the rear until it is in transport position. Hold **TRAILER TILT (5TH WHEEL)** lever in the down position until hydraulic system works against the bottomed out Hydraulic Tilt Cylinders. Hold **AXLE CONTROL** lever in the transport position until hydraulic system works against the fully extended hydraulic axle cylinder.
- 3-11.10 If necessary, unsecure the load, move load slightly forward or rearward on the load bed to get correct weight distribution on kingpin and the semitrailer axles, and resecure the load with the tiedowns and winch cable.

- 3-11.11 Shut down the auxiliary hydraulic power engine following operating instructions in **Section 3-13**.
- 3-11.12 Recheck that the load is properly secured. Assure maintenance schedule is up-to-date and semitrailer is ready to be pulled.
- 3-11.13 The gearbox operates a chain drive that makes a continuous loop from front of trailer to the rear of trailer. The gearbox can move the chain either clockwise or counterclockwise. The chain closest to the center of the trailer is used to pull or push the container on or off.
- 3-11.14 The pullouts are used to guide the container onto the trailer. Position in for 96" wide container and use the outer position for 102" wide container (**See Figure 3-3**).

IMPORTANT

SECTIONS 3-11.15 and 3-11.16 are same for loading all containers.

- 3-11.15 Check the container to be loaded to see if the container front corner castings are an inch or so off the ground. If they are not, the container will have to be lifted first and blocks placed a few inches behind front of container to keep container an inch or so off the ground (**See Figure 3-4**).
 - a. The trailer can be used to lift empty containers. The trailer should be straight in front of container and as close to container as possible without hitting container.
 - b. Operating trailer using the same methods described earlier in this section, move the undercarriage forward a couple feet and tilt the front of trailer up fully.

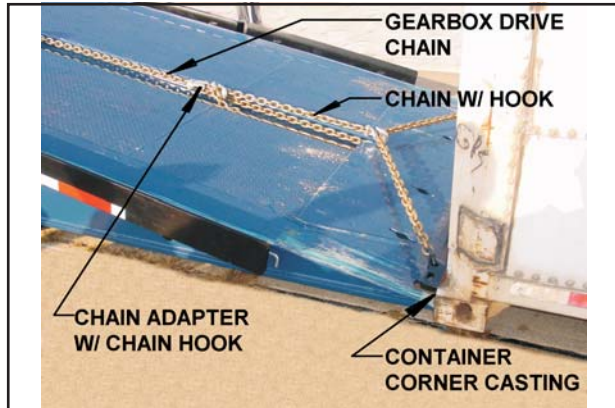

Figure 3-5 Chain Connections

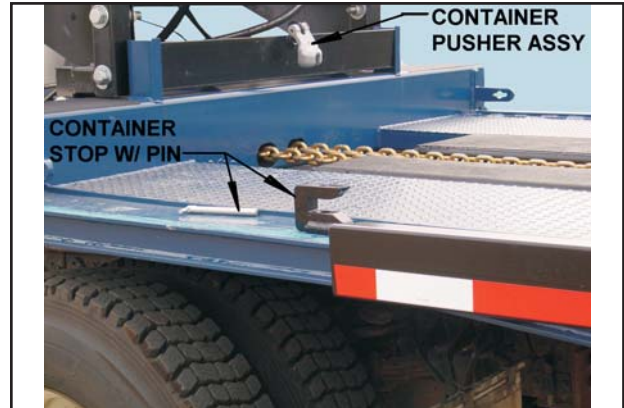

Figure 3-6 Container Pusher Assembly and Stops

- c. Connect the container chain harnesses provided with trailer to the container corner castings (**See Figure 3-5**).
- d. Connect the chain adapter with chain hook onto the gearbox drive chain.
- e. Connect chain hook into another chain with hook which connects into center of container chain harness.
- f. Operate the gearbox to tighten the chain. **See Section 3-10** for gearbox operating instructions.
- g. Tilt the trailer down until the front of container is lifted enough to block up an inch or so.
- h. Install provided container stops on the trailer where front of container is going to be pulled up to (**See Figure 3-6**).

3-11.16 Pull undercarriage forward and tilt the rear of trailer to within a half inch off the ground.

- a. Move trailer back under front of container a few inches.
- b. Tighten chain attached to container by operating gearbox.
- c. The truck and trailer can be pulled under container by releasing both truck and trailer brakes, but make sure either the container or trailer approach plate is always on the ground so the truck and trailer do not roll away freely. An operator needs to be in the truck to apply the brakes just in case the truck and trailer do start to roll away freely.
- d. Operate gearbox until container is on trailer five feet.
- e. The chain with hook can now be removed and the container chain harness connected directly to chain adapter with chain hook. This will allow the container to be pulled on farther (**See Figure 3-5**).

3-11.17 For loading two 20' containers, operate gearbox until first container is up against container stops. When container is against stops, the container harness is to be pinned to stops with pins provided.

- a. Disconnect chain adapter with chain hook from gearbox drive chain.
- b. Connect rear of 20' container to trailer with container stop assembly provided (**See Figure 3-7**).
- c. To load the second 20' container or just one 20' container, install container stops in the rear set of slots in the trailer top flange.
- d. The same procedure is used as loading the first 20' container except stop the container a couple feet behind the stops so the rear feet can be installed into bottom of container corner castings (**See Figure 3-7**).
- e. The trailer has to be tilted down so the rear of container is off the ground enough to install feet.



Figure 3-7 Loading Two Containers

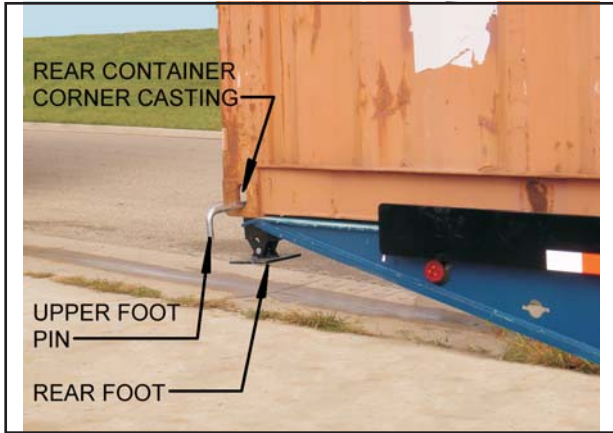

Figure 3-8 Loaded Container w/ Rear Foot

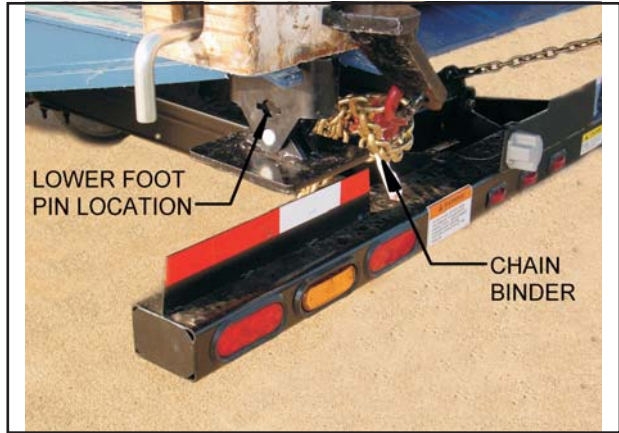

Figure 3-9 Location of Lower Foot Pin Under Approach Plate

- f. After feet are installed, the container can be pulled up to stops (**See Figure 3-8**).
- g. Pin container harness to stops with pins provided.
- h. Install pin in bottom of feet which should be guided into approach plate (**See Figure 3-9**).

3-11.18 Loading a 40' container is the same as a single 20' container except the stops are in the second set of slots behind front of trailer.

3-11.19 Loading a 45' container is similar to a single 20' container except that no stops are used since the container will go into the stops welded onto front of trailer (**See Figure 3-10**).

- a. The undercarriage has to be used to pull the container on the last four feet of the trailer. With the container within four feet of the front of the trailer, the feet in the rear container corner castings, and with trailer tilted down, remove the container chain harness.
- b. Remove the chain adapter with chain hook from the gear box chain.
- c. Move the undercarriage all the way back.
- d. Connect chains on undercarriage to rear container corner castings.
- e. Move undercarriage forward until front of container goes into front trailer feet and rear feet go into approach plate.
- f. Install pin in rear feet under approach plate (**See Figure 3-9**). Move undercarriage all the way back.
- g. Use chain binders to tighten the chain from undercarriage to container (**See Figure 3-9**).

3-11.20 Use the same procedure for returning the loaded trailer back to transport as described in **Sections 3-11.9 through 3-11.12**.

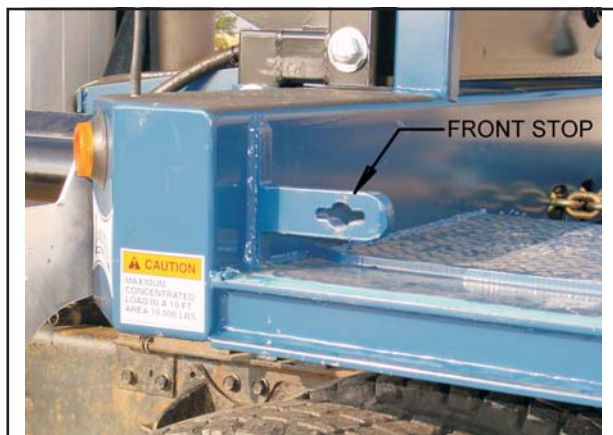
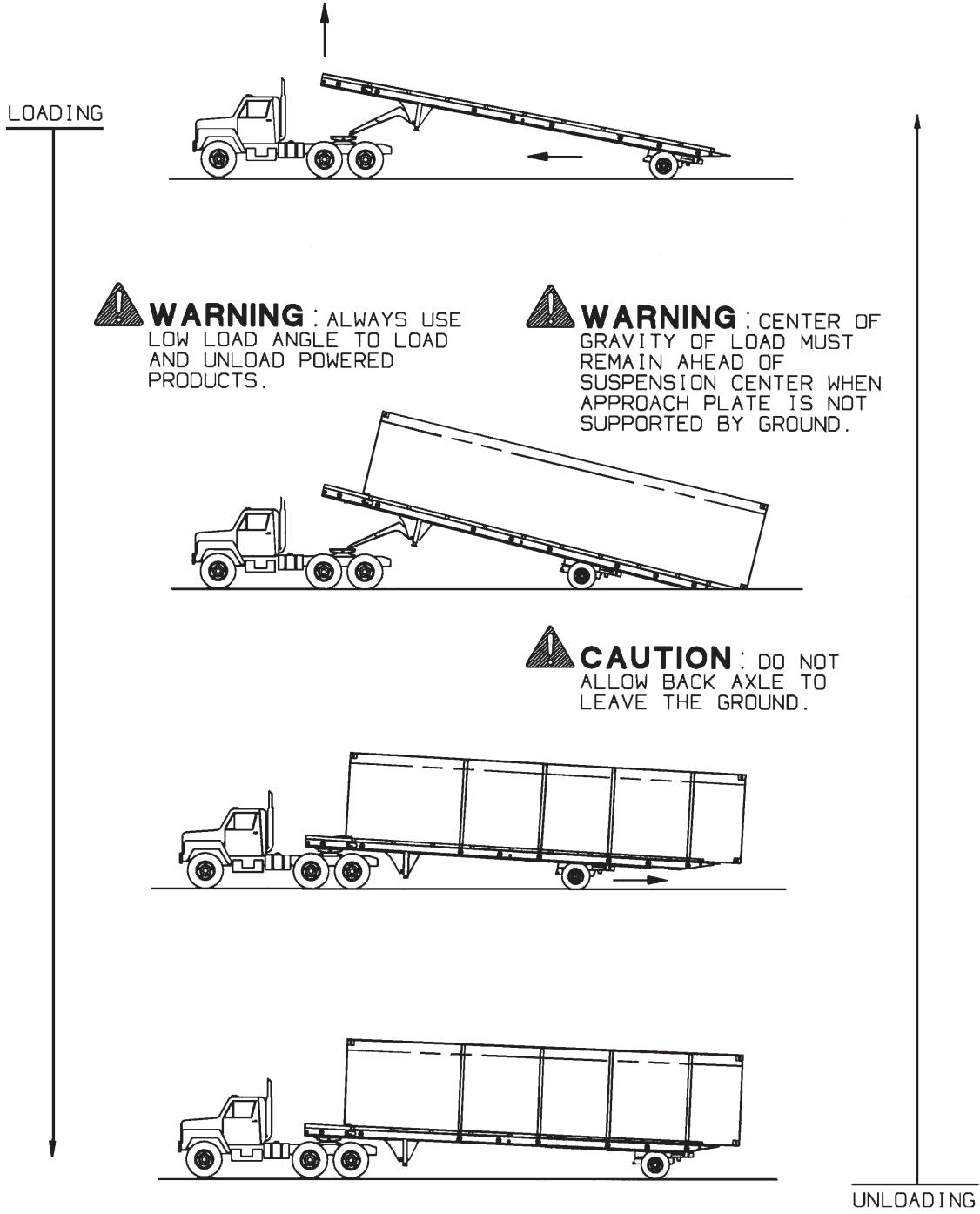

Figure 3-10 Front Stop Used w/ 45' Containers



3mc410-011503a

Figure 3-4 Steps for Loading and Unloading

3-12 UNLOADING THE TRAILER

WARNING

NEVER TILT THE TRAILER WITHOUT THE LOAD PROPERLY RESTRAINED. FAILURE TO DO SO MAY RESULT IN THE LOAD MOVING RESULTING IN SERIOUS PERSONAL INJURY, DEATH, OR DAMAGE TO PROPERTY IN IT'S PATH.

WARNING

DO NOT PULL THE REAR AXLE OF TRAILER FARTHER FORWARD THAN THE CENTER OF GRAVITY OF THE PAYLOAD WHEN REAR APPROACH PLATE IS OFF THE GROUND. FAILURE TO OPERATE CORRECTLY CAN ALLOW FRONT OF TRAILER TO GO UP AND PULL TOWING TRUCK OFF THE GROUND RESULTING IN SERIOUS PERSONAL INJURY, DEATH, OR DAMAGE TO PROPERTY IN ITS PATH.

- 3-12.1 Practice all standard industrial safety standards (**See Figure 3-4**).
- 3-12.2 Park towing vehicle and trailer on relatively level ground.
- 3-12.3 Set towing vehicle's brakes.
- 3-12.4 Engage the P.T.O. or start the hydraulic power engine.

IMPORTANT

SECTIONS 3-12.5 THRU 3-12.10 DESCRIBE GENERAL UNLOADING PROCEDURES FOR THE SEMITRAILER. SECTIONS AFTER 3-12.10 ARE MORE SPECIFIC OPERATION PROCEDURES FOR UNLOADING CONTAINERS.

3-12.5 Alternate between raising the trailer and pulling the axles forward until the approach plate touches the ground. Never pull the axles forward so far that center of gravity of the load and trailer are behind the rear axle of the trailer unless the approach plate is on the ground. Always use low load angle to unload powered products. To achieve low load angle, the undercarriage has to be all the way forward. The object is to keep a part of the weight on the approach plate, and part of the weight on the wheels while lowering the tilt angle. The maximum load angle is only intended, if required, for unloading non-powered products and to transfer load to tractor. Transfer load to tractor by raising deck and moving axles toward rear until load is forward of the rear axle, thus transferring load to tractor.

3-12.6 If load is non-powered, insure that the gearbox drive chain is firmly attached to the load and tension is on the chain. Tilt trailer according to **Section 3-12.5**. With chain firmly attached to load, remove other load securing devices. Use the gearbox to assist the load down to the end of the approach plate. With end of load resting on the ground, block load from rolling or sliding, if necessary. Disconnect the chain connectors and move the trailer from under the load, allowing the load to move off trailer to the ground.

WARNING

WHEN REMOVING LOAD, INSURE THAT THE LOAD IS STEERING STRAIGHT SO IT DOES NOT MANEUVER OFF THE SIDE OF THE TRAILER. FAILURE TO DO SO COULD RESULT IN DAMAGE TO EQUIPMENT, INJURY, OR DEATH.

3-12.7 If load is powered, tilt trailer according to **Section 3-12.5**. Make sure the trailer tilt is at the lowest load angle. Remove safety secure devices. Take tension off gearbox drive chain and remove chain connectors. Power load off the trailer.

3-12.8 Before returning the trailer to transport position, insure that there is sufficient distance between the load and the rear of the trailer so that the trailer does not hit the load when being folded back to transport position.

| |
|---|
|  CAUTION |
| BEFORE RETURNING THE TRAILER TO TRANSPORT POSITION, INSURE THAT THERE IS SUFFICIENT DISTANCE BETWEEN THE LOAD AND THE REAR OF THE TRAILER. FAILURE TO DO SO MAY RESULT IN DAMAGE TO THE TRAILER AND/OR LOAD. |

3-12.9 Tilt the bed down and move undercarriage rearward to transport position. Hold **TRAILER TILT (5TH WHEEL)** lever in the down position until hydraulic system works against the bottomed out Hydraulic Tilt Cylinders. Hold **AXLE CONTROL** lever in the transport position until hydraulic system works against the fully extended hydraulic axle cylinder.

3-12.10 Disengage the P.T.O. system of tractor or shut off the hydraulic power engine.

3-12.11 The unloading of containers is similar to unloading other loads. The procedures for getting the trailer ready to unload are the same.

3-12.12 For unloading a single 20' container, remove tiedown restraints such as chain binders, feet, and pins from the container before tilting the trailer (**See Figure 3-9**). Make sure nothing is behind the trailer for several feet in case the container starts sliding back when the trailer is tilted.

a. Connect the container pusher angle in front of the container into the gearbox chain (**See Figure 3-6**).

b. Tilt the trailer at a low load angle until the approach plate is on the ground.

c. Power the container off with the gearbox until the rear of container is on the ground.

See Section 3-10 for gearbox operating instructions.

d. The truck and trailer can now be pulled forward out from underneath the container.

3-12.13 For unloading two 20' containers, remove tiedown restraints such as chain binders, feet, and pins from the rear container before tilting the trailer (**See Figure 3-9**).

a. Tilt the trailer until the rear feet in container rear corner castings hit the ground.

b. Pull the truck and trailer ahead a couple feet so the container is off the trailer a couple feet.

c. Tilt the trailer back down and remove the rear feet.

d. Tilt trailer until the rear of container hits the ground.

e. The truck and trailer can now be pulled forward out from underneath the container.

f. Unload second 20' container as described in **Section 3-12.12**.

3-12.14 For unloading a 40' container, use the same procedure as unloading a 20' container (**See Section 3-12.12**).

3-12.15 For unloading a 45' container, the container has to be moved back off the trailer a couple feet before the container pusher angle can be installed since the 45' container is all the way to the front of the trailer. Do this by removing tiedown restraints such as chain binders, feet, and pins from the rear container before tilting trailer.

a. Tilt trailer until container feet hit the ground and lifts the rear of container up slightly.

b. Pull the truck and trailer forward a couple feet so container is off trailer a couple feet.

c. Tilt trailer down and remove container rear feet.

d. The 45' container can now be removed using the same procedure as unloading a 20' container (**See Section 3-12.12**).

3-12.16 Use the same procedure for returning the trailer back to transport as described in **Sections 3-12.8 and 3-12.9**.

3-13 AUXILIARY HYDRAULIC POWER ENGINE OPERATION

3-13.1 The Hydraulic Power Supply Engine is used to power the hydraulic functions, should the tractor not be equipped with hydraulic hookups.

IMPORTANT

1. CHECK THE FOLLOWING FLUID LEVELS BEFORE STARTING THE ENGINE PACKAGE: ENGINE OIL, FUEL SUPPLY, HYDRAULIC OIL. (CHECK OIL LEVEL WHILE SEMITRAILER IS NOT TILTED AS TILTING WILL CHANGE THE OIL LEVEL IN THE TANK.)

2. IF THE ENGINE DOES NOT CRANK, CHECK THE FOLLOWING ON THE BATTERY: CHARGE, FLUID, TERMINALS, AND CABLES. TAKE CORRECTIVE ACTIONS AS NEEDED.

CAUTION

IF THE HYDRAULIC FLUID LEVEL IS LOW DURING OPERATION, THE SEMITRAILER MAY NOT OPERATE CORRECTLY, RESULTING IN DAMAGE TO THE SEMITRAILER.

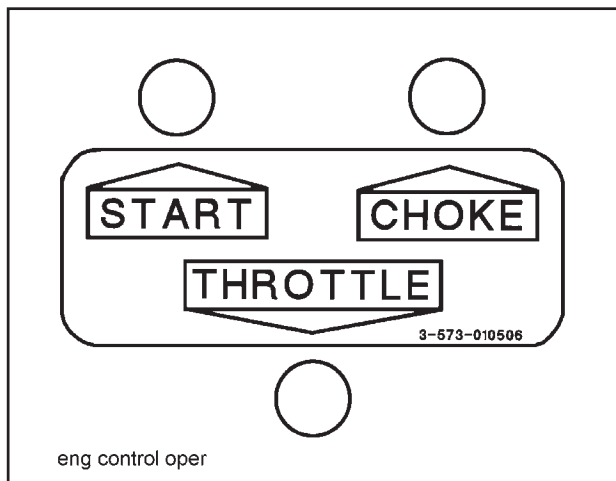

Figure 3-12 Engine Control Panel

3-13.2 The Engine Ignition Switch, Choke and Throttle are on the Engine Control Panel mounted on the drivers side by the hydraulic controls. (See Figure 3-12).

3-13.3 The **HYDRAULIC POWER SUPPLY ENGINE THROTTLE** controls the speed at which the engine operates (See Figure 3-12). It is a variable position control:

HIGH In this position, the engine throttle is fully open, letting it run at full speed.

LOW In this position, the engine throttle is closed, letting the engine run at a slow idle.

3-13.4 To start pull the choke completely out and set the throttle to the LOW position.

3-13.5 Turn the ignition key to the START position. The engine should crank and then start.

CAUTION

DO NOT CRANK ENGINE FOR MORE THAN 30 SECONDS. IF ENGINE DOES NOT START CONSULT THE OWNER'S MANUAL SUPPLIED WITH THE ENGINE.

3-13.6 When the engine starts, release the key. Gradually push the choke lever in until the engine runs smoothly.

3-13.7 Black smoke from the exhaust and a rough running engine usually indicate over-choking.

3-13.8 To adjust the speed, turn the throttle control in or out, as needed, until the engine runs smoothly at a speed capable of withstanding use of the hydraulic controls. The hydraulic controls should now be functional.

3-13.9 Before shutting it off, allow the engine to cool down by running at a slow idle for one to two minutes. Then turn the ignition switch to the off position.

3-13.10 Once the engine is cool, turn or push the throttle and choke control completely in and turn the key to the OFF position.

3-14 BULKHEADS

 **DANGER**

TO AVOID SERIOUS INJURY ALL REMOVABLE ATTACHMENTS MUST BE FIRMLY ATTACHED WITH FASTENERS PROVIDED AT ALL TIMES

To remove a bulkhead, take out the pins holding bulkhead into the pockets on the semitrailer front and lift the bulkhead off.

3-15 REAR IMPACT GUARD SYSTEM

Vehicle standards FMVSS No. 224, Rear Impact Protection, requires all semitrailers manufactured after January 26, 1998 shall be equipped with a rear impact guard certified by the manufacturer as meeting FMVSS No. 223, Rear Impact Guards. The guard, or bumper, meets the following requirements:

- a minimum of 4 inches vertical height
- extend laterally to within 4 inches of the sides of the trailer
- have a ground clearance of no more than 22 inches
- be placed no more than 12 inches from the rear of the trailer

The standard also specifies minimum force and energy absorption requirements for the guard. A DOT decal certifies that the guard meets FMVSS No. 223 and 224 standards. The decal is placed **and must remain at all times** on the forward facing surface of the guard, 12 inches inboard of the curb side and of the guard. **See Figure 3-13** for location of decals.

Replace any component that does not allow the above minimum requirements to be met. Any hardware that holds the rear impact guard and becomes damaged or becomes loose shall be removed and replaced. The 3/4" grade 8 screws that hold the bumper energy pack shall be loctited and torqued to 280 ft.-lbs.

 **DANGER**

ALWAYS CHECK THE CONDITION OF THE REAR BUMPER ENERGY PACK. IF PACK HAS BEEN DAMAGED, IT MUST BE REPLACED. FAILURE TO MAINTAIN ENERGY PACK MAY RESULT IN INJURY OR DEATH TO OTHERS.

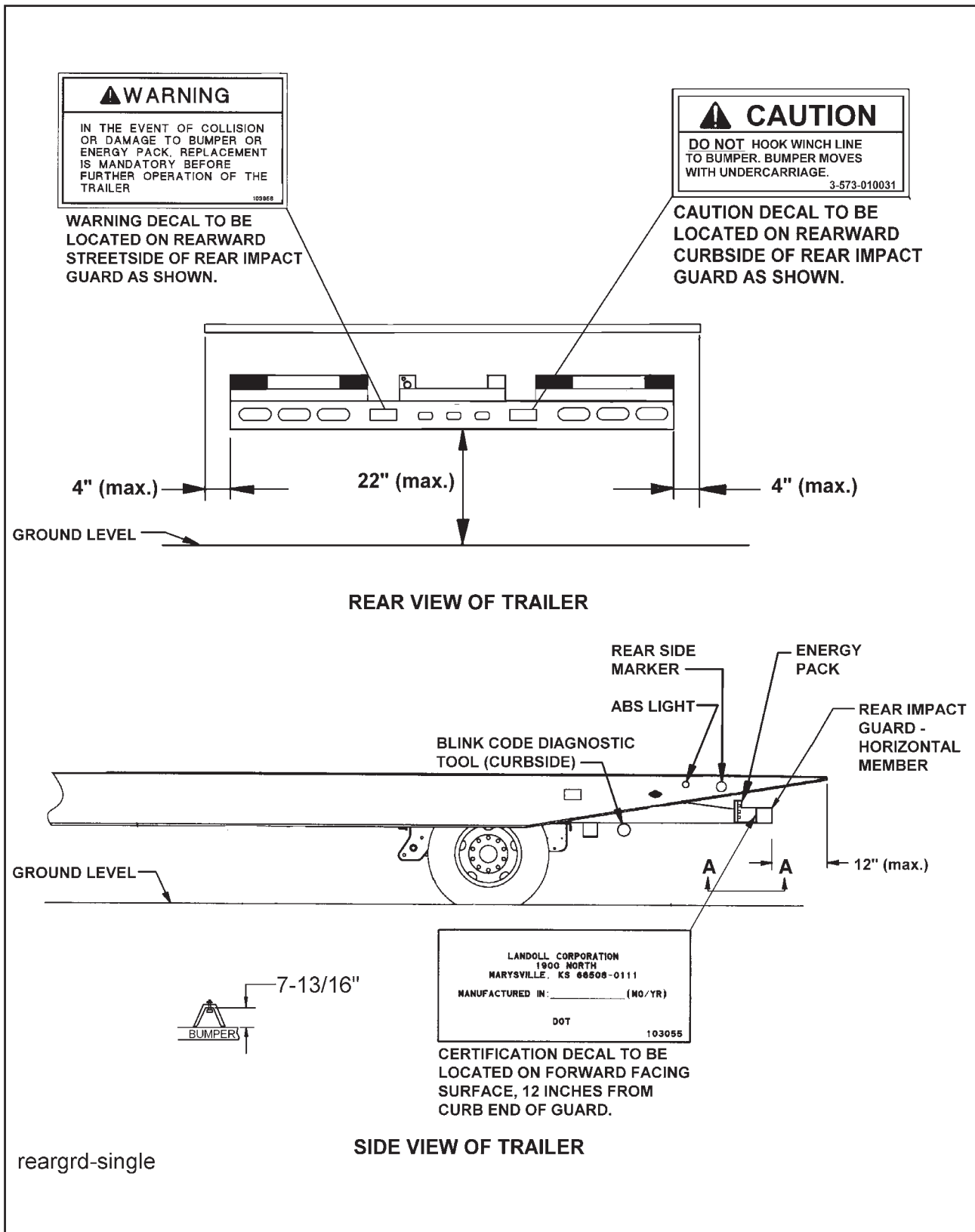

Figure 3-13 Rear Impact Guard System

3-16 ANTI-LOCK BRAKE SYSTEM (ABS)

Vehicle standards FMVSS No. 121, anti-lock brake system requires all trailers with air brake systems to have ABS after March 1, 1998. Each trailer (including a trailer converter dolly) shall be equipped with an anti-lock brake system that controls the wheels of at least one axle of the trailer. Wheels on other axles of the trailer may be indirectly controlled by the anti-lock brake system.

NHTSA Docket 92-29; notice 11 published September 23, 1996 specifies the ABS warning light be mounted near the rear of the left side of the trailer (See Figure 3-13).

- **decals or lens marking with ABS to identify the lamp**
- **the lamp must illuminate one time whenever power is supplied to the ABS. At any time the light remains on when power is supplied there is a malfunction to the system.**

The ABS used on the semitrailer is a commercial unit. Single axle trailers use a two sensor, one modulator system.

The ABS is constant powered by the auxiliary (blue) circuit, center pin on the semitrailer seven way electrical connector. This circuit must be hot whenever the tractor keyswitch is on. This circuit must also not be used to power any additional electrical devices while the semitrailer is moving forward. However, additional devices such as remote controls may be powered from the auxiliary circuit while the semitrailer is stationary. Back up power to the ABS is supplied through the stop lamp (red) circuit, No. 4 pin on the seven way connector, and ground is supplied by the white wire, No. 1 pin.

CAUTION

THE AUXILIARY (BLUE) CIRCUIT IS FOR POWERING THE SEMITRAILER ABS. THIS CIRCUIT MUST BE HOT WHEN THE TRACTOR KEY SWITCH IS ON. NO OTHER ELECTRICAL DEVICES MAY BE POWERED BY THIS CIRCUIT WHILE THE SEMITRAILER IS MOVING FORWARD.

Malfunction in the ABS is signaled by illumination of the ABS warning lamp located at the left rear side of the semitrailer. The warning lamp will come on and stay on while power is supplied to the ABS on a moving vehicle, if there is a fault. If a fault in the ABS exists, normal braking will still occur, but wheels may lock. The semitrailer is still operable, but the system should be serviced as soon as possible.

CAUTION

IF A FAULT EXISTS IN THE SEMITRAILER ABS, NORMAL BRAKING WILL OCCUR, BUT WHEELS MAY LOCK. SERVICE THE ABS AS SOON AS POSSIBLE.

The ABS is also equipped with a Blink Code Diagnostic Tool mounted at the right rear corner of the undercarriage or at the very rear of the trailer. This tool is used to identify faults that may occur in the ABS so that they may be repaired.

Refer to ABS maintenance manual supplied with semitrailer to answer basic questions for the anti-lock brake system, obtain outline procedures on how to adjust, test, remove, and install ABS components, as well as how to test for faults in the system by using "Blink Code Diagnostics"; and illustrates ABS components, wiring, and plumbing installation diagrams.

3-17 COLD WEATHER OPERATION

3-17.1 Cold weather causes lubricants to congeal, insulation and rubber parts to become hard, which may lead to problems found in bearings, electrical systems, and air systems. Moisture attracted by warm parts can condense, collect and freeze to immobilize equipment. The truck/trailer operator must always be alert for indicators of cold weather malfunctions.

3-17.2 During any extended stop period, neither the service nor parking brake should be used as they can freeze up. Use wheel chocks to secure the vehicle from moving.

3-17.3 Check all structural fasteners, air system fittings, gaskets, seals and bearings for looseness that can develop due to contraction with cold. Do not over-tighten.

3-17.4 Check tire inflation. Tire inflation decreases when the temperature decreases.

3-17.5 Periodically check drain holes in the bottom of the relay valve (for trailers with air brakes) and storage compartments. They must be open at all times to avoid moisture entrapment.

3-18 HOT WEATHER OPERATION

3-18.1 Hot weather operation can cause expansion of parts, resulting in tightening of bearings, fasteners, and moving parts. Failure of gaskets or seals can occur.

3-18.2 The trailer should be parked in the shade if possible. Long exposure to the sun will shorten service life of rubber components (i.e., tires, light and hose grommets, hoses, etc.) and paint life.

3-18.3 Check tire pressure early in the day before beginning operations while the tire is cool. Put all valve stem caps back on after checking.

3-18.4 If the area is extremely humid, protect electrical terminals with ignition insulation spray. Coat paint and bare metal surfaces with an appropriate protective sealer.

3-18.5 For trailers with air brakes, the use of a filter-lubricator in the towing vehicle's air delivery system is recommended.

This section contains instructions necessary for proper maintenance of the semitrailer. The 340 semitrailer is designed for years of service with minimal maintenance. However, proper maintenance is important for durability and safe operation and is an owner/user responsibility.

DANGER

OPERATING THE TRACTOR OR SEMI-TRAILER WITH DEFECTIVE, BROKEN OR MISSING PARTS MAY RESULT IN SERIOUS INJURY OR DEATH; DAMAGE TO THE TRACTOR/TRAILER, ITS CARGO, OR PROPERTY IN ITS PATH.

4-1 MAINTENANCE SCHEDULE

Semitrailer maintenance includes periodic inspection and lubrication. **Table 4-2, Maintenance Schedule**, lists the recommended maintenance and lubrication tasks by time interval and by accumulated mileage (use whichever occurs first). **Table 4-3, Hydraulic Engine Maintenance Schedule**, lists the recommended maintenance tasks for the hydraulic engine package.

4-1.1 Inspection

- a. Inspect the tractor, the semitrailer, and semitrailer parts periodically for damage or signs of pending failure. Damaged or broken parts must be repaired or replaced at once. Determine the cause of any binding or hydraulic leakage at once. Correct the problem before using the tractor or semitrailer.
- b. Use the Troubleshooting Guide to check for "SYMPTOMS" and "PROBLEMS" of any semitrailer system not functioning correctly, or where wear, distortion, or breakage are found. Administer "REMEDY" according to the right-hand column of the Troubleshooting Guide.

4-1.2 Lubrication

Figure 4-1 and Table 4-1 details lubrication points and intervals, method of application, and lubricant required, and illustrates the location of each part to be lubricated. During inspections of the semitrailer, if lubricants are found to be fouled with dirt or sand, those parts should be cleaned with paint thinner, dried, and relubricated immediately. Dirt in a lubricant forms an abrasive compound that will wear parts rapidly.

WARNING

PAINT THINNER AND OTHER SOLVENTS ARE FLAMMABLE AND TOXIC TO EYES, SKIN, AND RESPIRATORY TRACT. AVOID SKIN AND EYE CONTACT. GOOD GENERAL VENTILATION IS NORMALLY ADEQUATE. KEEP AWAY FROM OPEN FLAMES OR OTHER COMBUSTIBLE ITEMS.

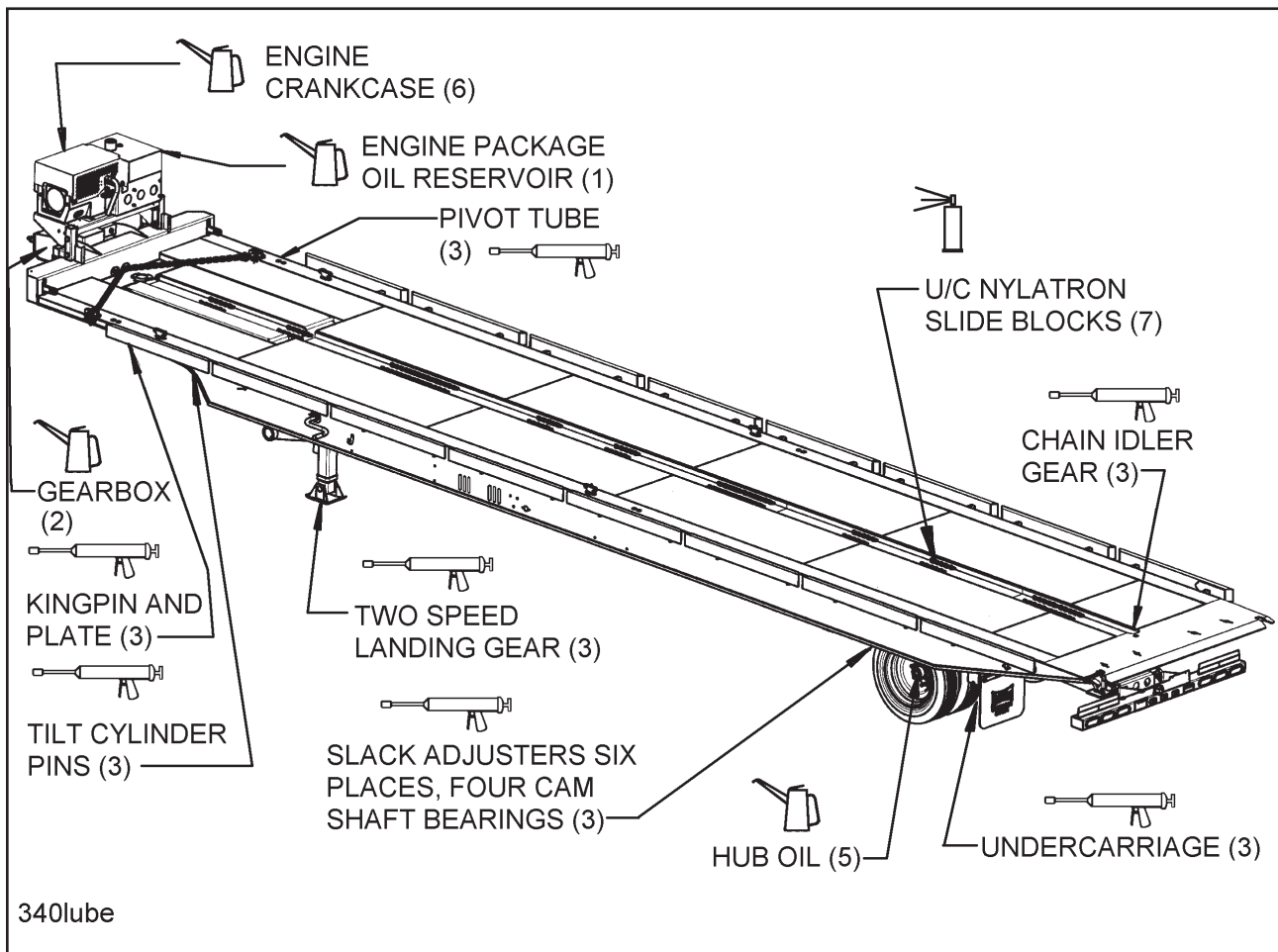

Figure 4-1 Lubrication Points

| LUBE | SEASON | BRAND AND PRODUCT (WEIGHT AND/OR TYPE) | | | |
|------|-------------|---|-----------------------------|---------------------------------|--------------------------|
| | | AMOCO | EXXON | PHILLIPS | TEXACO |
| 1 | ALL YEAR | Rycon MV | HDX Plus 10W | Mangus Oil A KV 5W-20 | Rando HD-AZ |
| *2 | ALL YEAR | Permagear EP 460 SAE 140 | Spartan 460 SAE 140 | Phil Gear Lube 460 SAE 140 | Meropa 460 SAE 140 |
| 3 | ALL YEAR | Lit-Multi-purpose Grease | Rondex Multi-purpose Grease | Phil Lube M.W. Grease | MarFax All Purpose |
| 4 | ALL YEAR | Industrial Oil 32 | Estic 32 | Condor 32 or Magnus 32 | Regal Oil R&O 32 |
| 5 | ALL YEAR | Gear Lube SAE 80W-90 | Gear Oil GX SAE 80W-90 | Superior MP Gear Oil SAE 80W-90 | Multi-gear EP SAE 80W-90 |
| 6 | ABOVE 0° F | Ultimate Gold 10W-30, 10W-40 | SuperFlow 10W-30, 10W-40 | Tropartic 10W-30, 10W-40 | Havoline 10W-30, 10W-40 |
| | BELOW 32° F | Ultimate Gold 5W-20, 5W-30 | SuperFlow 5W-20, 5W-30 | Tropartic 5W-20, 5W-30 | Havoline 5W-20, 5W-30 |
| 7 | ALL YEAR | Multi-Purpose Petroleum Based Lubricating Spray | | | |

* GEAR BOX GENERALLY LEAVES MANUFACTURING FACILITY USING MOBIL 85W140 GEAR LUBE.

Table 4-1 Lubrication Specifications

| NORMAL OPERATING SERVICE INTERVALS ^a | | | | | | | | |
|---|-------|-----------|--------|---------|----------|--------|--------|-------|
| SERVICE INTERVAL : | TIMES | 1st 5 Hrs | Weekly | Monthly | 6 Months | Yearly | LUBE # | NOTES |
| ITEM | MILES | 50 | 500 | 2,000 | 12,000 | 25,000 | | |
| LIGHTS | | I | I | | | | | |
| WIRING & CONNECTIONS | | I | | I | | | | |
| FASTENERS | | I, T | | I | | | | b |
| KING PIN & PLATE | | I | | C, I, L | | | 3 | c |
| BRAKE AIR SYSTEM | | I | I | I | | | | |
| RELAY VALVES | | | | | | I, C | | |
| BRAKE ADJ & WEAR | | I | | I, T | | | | d |
| SLACK ADJUSTERS | | I | I | | | L | 3 | c |
| CAMSHAFT ASSYS | | I | I | | | L | 3 | c |
| HUB OIL | | I | I, L | | | R | 5 | c |
| WHEEL BEARINGS | | I | | | I, T | | 5 | c |
| TIRE INFLATION & WEAR | | I | I | | | | | e |
| WHEEL LUG NUTS | | I, T | I | I, T | | | | f |
| SUSPENSION ALIGNMENT | | I | | I | | | | |
| UNDERCARRIAGE NYLATRON BLOCKS | | | L | | | | 7 | c |
| HYDRAULIC OIL | | I | I | | | R | 1 | c |
| HYDRAULIC FILTER | | R | | | R | | | |
| HOSES | | I | | I | | R | | |
| GEARBOX | | I | | L | | | 2 | c |
| CHAIN IDLER GEAR | | I | | L | | | 3 | c |

I – Inspect, R – Replace, T– Tighten/ Adjust Torque, L – Lubricate, C – Clean

NOTES:

- Perform at the time shown. Shorten service intervals when operating in severe or dirty conditions.
- See **Tables 2-1 and 2-2 (General and Hydraulic Fitting Torque Charts)** for correct torque.
- See **Table 4-1 (Lube Specification Chart)** for recommended lubricant.
- Call Landoll Customer Services for procedures to replace.
- See Serial Number Plate on the front of the semitrailer for proper inflation requirements.
- See **Figure 4-18** , Stud Tightening Sequence.

Table 4-2 Maintenance Schedule

| ENGINE MAINTENANCE SCHEDULE | | | | | | | |
|---|-------------------------------------|----------------|----------------|----------------|----------------|-----|----------------|
| OPERATION | AFTER EACH CYCLE OF INDICATED HOURS | | | | | | |
| | 8 | 25 | 50 | 100 | 200 | 500 | 1000 |
| Inspect Engine Generally | X ¹ | | | | | | |
| Check Oil Level | X | | | | | | |
| Service Air Cleaner Element And Element Wrapper | | X ² | | | | | |
| Change Crankcase Oil (20 hp engine) | | X ³ | X ² | | | | |
| Change Crankcase Oil (24 hp engine) | | X ³ | | X ² | | | |
| Replace Oil Filter | | X ³ | | X ² | | | |
| Check Battery Electrolyte Level | | | X | | | | |
| Clean Cooling Fins | | | X ² | | | | |
| Replace Air Cleaner Element | | | | | X ² | | |
| Replace Fuel Filter | | | | | X | | |
| Check or Replace Spark Plugs | | | | | | X | |
| Check Valve Clearance | | | | | | | X ⁴ |
| Clean Carbon and Lead Deposits (cylinder head) | | | | | | | X ⁵ |
| NOTES: | | | | | | | |
| <p>X¹. Check for fuel leaks. With engine running, visually and audibly check exhaust system for leaks. X². Perform more often when running under severe operating conditions. X³. Required for initial break-in only. X⁴. For detailed maintenance, contact a service center or refer to the Service Manual. X⁵. Clean carbon more frequently when running under continuous light load and/or on leaded fuel. Use of carburetor and combustion cleaner is recommended every 200 hours to help reduce carbon buildup.</p> | | | | | | | |
| ⚠ WARNING | | | | | | | |
| BREATHING EXHAUST GASES CAN RESULT IN SEVERE PERSONAL INJURY OR DEATH. DO NOT USE AIR CLEANER, EXHAUST ELBOW, OR CONNECTING PARTS AS A SUPPORTING STEP. DAMAGE TO THESE AND CONNECTING PARTS CAN CAUSE AN EXHAUST LEAK. | | | | | | | |

Table 4-3 Hydraulic Engine Maintenance Schedule

4-2 MAINTENANCE PROCEDURES

4-2.1 Tools and Equipment. Tools, equipment, and personnel normally found in a facility capable of making truck repairs will be adequate for maintenance of the semitrailer. No other special tools or equipment should be necessary.

4-2.2 Standard Torque Values. Tables 2-1 and 2-2 lists torque values for standard hardware and is intended as a guide for average applications involving typical stresses and mechanical surfaces. Values are based on the physical limitations of clean, plated, and lubricated hardware. In all cases, when an individual torque value is specified, it takes priority over values given in this table. Replace original fasteners with hardware of equal grade.

WARNING

PAINT THINNER AND OTHER SOLVENTS ARE FLAMMABLE AND TOXIC TO EYES, SKIN, AND RESPIRATORY TRACT. AVOID SKIN AND EYE CONTACT. GOOD GENERAL VENTILATION IS NORMALLY ADEQUATE. KEEP AWAY FROM OPEN FLAMES OR OTHER COMBUSTIBLE ITEMS.

4-2.3 Cleaning

- a. Wash semitrailer to remove all accumulated dirt and grime.
- b. Use any mineral spirits paint thinner (or its equivalent) to remove grease and oil from all parts of the semitrailer. Rinse degreasing solution off with cold water.
- c. Inspect semitrailer for cause of any reported troubles.
- d. Scrape, sand, prime, and repaint areas where finish is missing or where there is evidence of corrosion.
- e. After disassembling any components, thoroughly clean dirt and old lubricant from all parts. Do not use a wire brush on any bearing parts or surfaces — use a stiff bristle brush. Do not use compressed air, or spin bearing parts when cleaning. These practices can throw solvents, dirt, or metal particles into your eyes. Dry clean parts with lint free, clean, soft, absorbent, cloth or paper. Wash and dry hands.
- f. Inspect seals, seal wiping surfaces, bearing caps, and bearing cones for wear, pitting, chipping, or other damage.

4-3 HITCH, FRAME, AND DECK

4-3.1 Repairing Structural Defects

If any structural defect is found, the fault must be corrected before further use of the vehicle. To continue usage could endanger the semitrailer, its load, personnel, traffic, and properties. Inspect the deck daily for broken or missing planks or missing attachments. Replace any defective parts promptly.



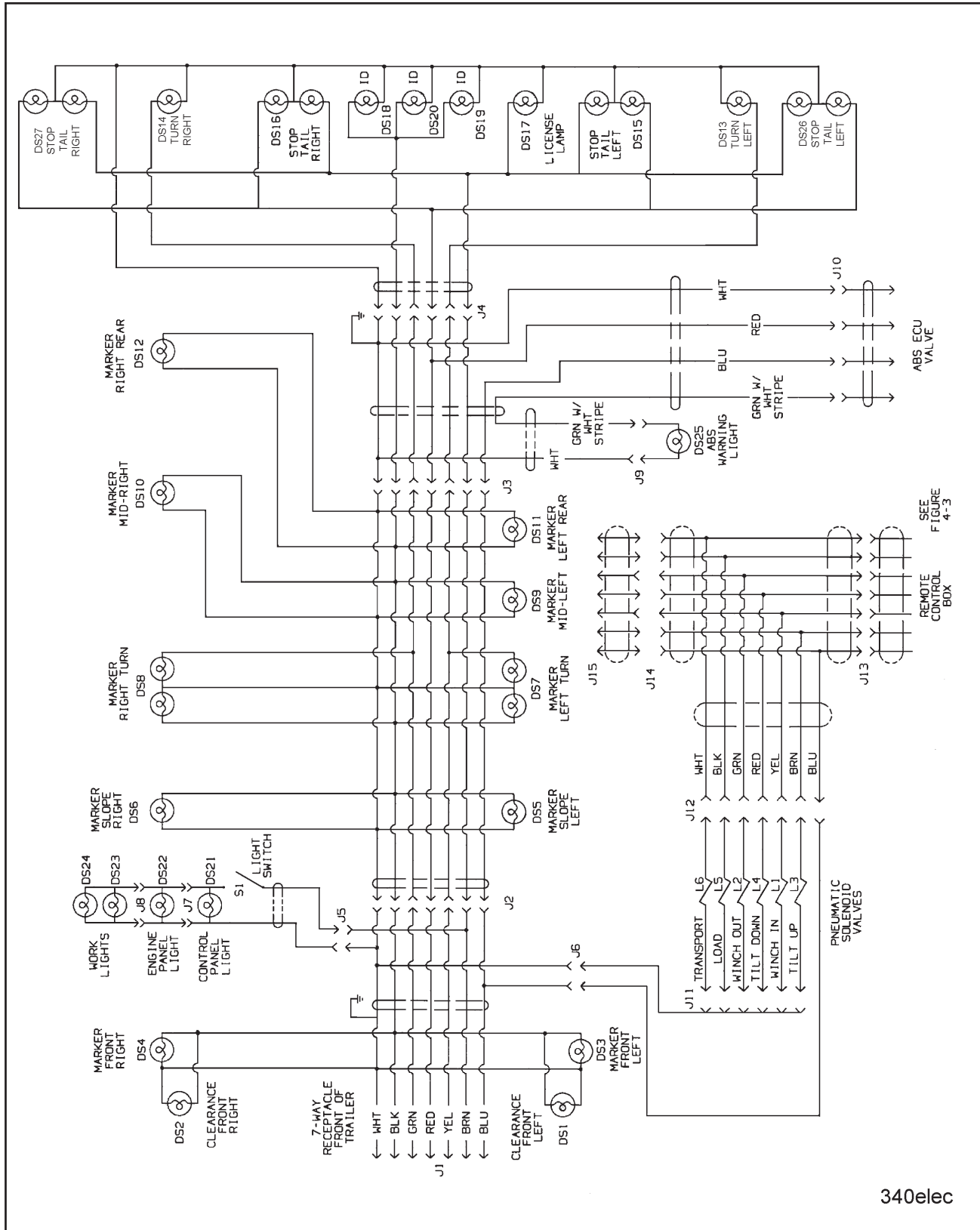
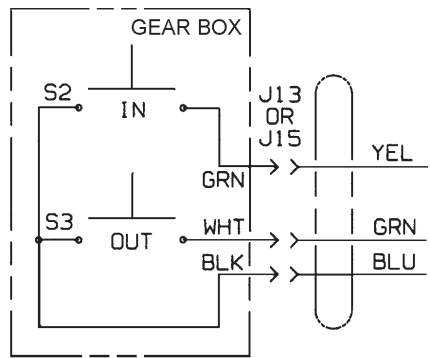
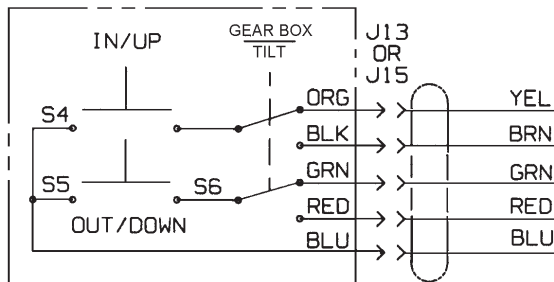

Figure 4-2 340 Wiring Diagram



WIRED REMOTE 3-209-010001

SINGLE FUNCTION - GEAR BOX



WIRED REMOTE 3-209-010004

DUAL FUNCTION - GEAR BOX / TILT

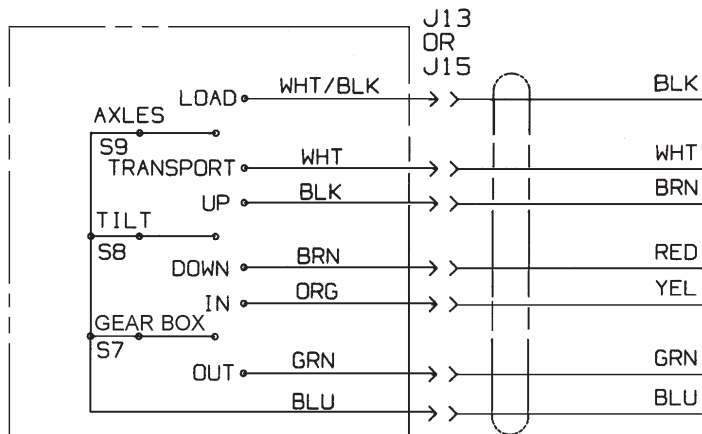

WIRED REMOTE 3-209-010006

TRIPLE FUNCTION - GEAR BOX / TILT / AXLE

3ma208-010053

Figure 4-3 Remote Wiring Diagram

| 340 WIRING PARTS LIST | | 340 WIRING PARTS LIST | |
|-----------------------|-----------------------------------|-----------------------|--|
| REF. DES. | FUNCTION | REF. DES. | FUNCTION |
| DS1 | FRONT LEFT CLEARANCE, YELLOW | DS26 | LEFT STOP/TAIL, RED |
| DS2 | FRONT RIGHT CLEARANCE, YELLOW | DS27 | RIGHT STOP/TAIL, RED |
| DS3 | FRONT LEFT MARKER, YELLOW | J1 | FRONT MAIN CONNECTOR |
| DS4 | FRONT RIGHT MARKER, YELLOW | J2 | LOWER DECK CONNECTOR |
| DS5 | LEFT SLOPE MARKER, YELLOW | J3 | U/C CONNECTOR |
| DS6 | RIGHT SLOPE MARKER, YELLOW | J4 | BUMPER CONNECTOR |
| DS7 | LEFT SIDE MARKER/TURN, YELLOW | J5 | AUX. LIGHTS PWR/GRND CONN |
| DS8 | RIGHT SIDE MARKER/TURN, YELLOW | J6 | REMOTE CONTR.PWR/GRND CONN |
| DS9 | MID-LEFT SIDE MARKER, YELLOW | J7 | ENGINE PANEL LIGHT |
| DS10 | MID-RIGHT SIDE MARKER, YELLOW | J8 | WORK LIGHTS |
| DS11 | LEFT REAR SIDE MARKER, RED | J9 | ABS LAMP CONNECTOR |
| DS12 | RIGHT REAR SIDE MARKER, RED | J10 | ABS ECU VALVE CONNECTOR |
| DS13 | LEFT TURN, YELLOW | J11 | GRND CONN TO SOLENOID VLVS. |
| DS14 | RIGHT TURN, YELLOW | J12 | PWR & FUNCTION CONNECTION TO SOLENOID VALVES |
| DS15 | LEFT STOP/TAIL, RED | J13 | REMOTE, STREET REAR |
| DS16 | RIGHT STOP/TAIL, RED | J14 | CURBSIDE REMOTE CONN |
| DS17 | LICENSE PLATE LIGHT | J15 | REMOTE, CURB REAR |
| DS18 | IDENTIFICATION RIGHT, RED | L1 | GEAR BOX IN |
| DS19 | IDENTIFICATION LEFT, RED | L2 | GEAR BOX OUT |
| DS20 | IDENTIFICATION CENTER, RED | L3 | TILT UP |
| DS21 | CONTROL PANEL, LH | L4 | TILT DOWN |
| DS22 | CONTROL PANEL, RH | L5 | AXLE LOAD |
| DS23 | FIRST WINCH LIGHT | L6 | AXLE TRANSPORT |
| DS24 | FIRST WINCH LIGHT | S1 | WORK LIGHT |
| DS25 | ABS MALFUNCTION INDICATOR, YELLOW | S2 | GEAR BOX IN |

Figure 4-4 340 Wiring Parts List

4-4 HYDRAULIC SYSTEM

4-4.1 General

- a. Check the oil level of the tractor wet kit hydraulic tank weekly, or after any leakage. See **Table 4-1** for proper hydraulic oil. Check the hydraulic oil level with hydraulic cylinders in the retracted position. Disengage the hydraulic pump.
- b. Overfilling can cause hydraulic fluid overflow during operation.
- c. Hydraulic system pressure relief valves should be set at 2500 PSI.

4-4.2 Hydraulic Engine Package

- a. Check the hydraulic oil level weekly, or after any leakage. See **Table 4-1** for proper hydraulic oil. Check oil level with hydraulic cylinders in the retracted position and with the engine stopped.

- b. Check hoses weekly for cracks or leaks. If a valve or line leaks, it should be replaced immediately.
- c. Check the engine oil each time before using. Oil level should be maintained between the “**ADD**” and “**FULL**” marks on the oil dip stick.
- d. Replace hydraulic filter with new filter at least *every 6 months* or more often under adverse conditions.
- e. Use the fuel recommended for the engine package installed on your semitrailer.
- f. For further maintenance procedures and proper lubrication specifications, please refer to the engine owners manual that was supplied with the hydraulic engine package.

4-5 ELECTRICAL SYSTEM

4-5.1 Maintenance of the electrical system consists of inspection and minor servicing. Any wire, connection or electrical component showing signs of corrosion, wear, breakage or unraveling must be repaired or replaced.

4-5.2 Frayed or unraveling wire must have the defective section removed and replaced with wire of the same color and gauge. Seal all connections and insulate.

4-5.3 Corroded terminals must have the corrosion removed, source of corrosion neutralized and the terminals resealed, protected, and insulated.

4-5.4 Fuse or circuit breaker burn-out or blow-out usually indicates an electrical short-circuit, although a fuse can occasionally fail from vibration. Insert a second fuse or reset the breaker. If this fuse immediately burns out or the breaker trips, locate the cause of the electrical short and repair.

4-5.5 A light that repeatedly burns-out usually indicates a loose connection, poor system ground, or a malfunctioning voltage regulator. Locate the source of the problem and repair. System grounds must be grounded to bare metal surfaces. Paint, grease, wax, and other coatings act as insulators. Replacement lamps must be equivalent to the factory installed lamp.

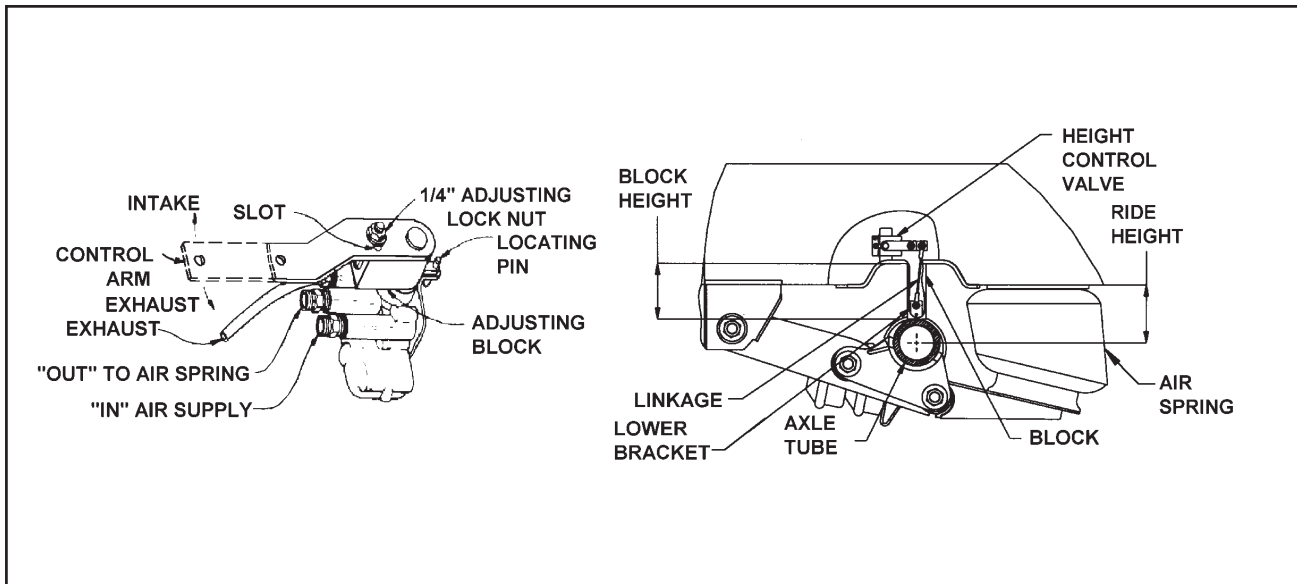

Figure 4-5 Air Ride Height Adjustment

4-6 SUSPENSION MAINTENANCE

4-6.1 Spring Suspension

- a. Make certain that all springs are properly located on the wear pads. Twisted springs or cocked hangers will cause uneven spring contact with wear pad and will result in excessive wear on the spring suspension. Check the shocks for excessive wear.
- b. Replacing the equalizer bushings and the torque arm bushings on the spring suspension is a complex operation and should be left to trained service personnel. If the bushings need to be replaced contact a Landoll authorized service center or the Landoll factory for servicing.

4-6.2 Air Ride Suspension

- a. Physically check all nuts, bolts, and air line fittings for proper torque (see torque chart below).

| AIR SUSPENSION TORQUE CHART | | | | |
|-----------------------------|----------|---------|----------|---------|
| Size | 1-1/8"-7 | 1/2"-13 | *3/4"-16 | 3/4"-10 |
| Torque in Ft. Lbs. | 800 | 35 | 35 | 150 |

* Air Spring Connections Only.

- b. Check all other suspension components for any sign of damage, looseness, wear or cracks.
- c. With trailer on level surface and air pressure in excess of 65 psi, all air springs should be of equal firmness. The height control valve on right side of front axle controls all air springs on tandem axle suspensions.

4-6.3 Air Ride Height Adjustment. (See Figure 4-5 for parts identification).

- a. Before adjusting, the vehicle must be empty with the kingpin at operating height and have air supplied to the trailer.
- b. Disconnect linkage at the control arm and raise control arm to the "up" position, raising the trailer until a block can be placed between axle tube and undercarriage frame (See Figure 4-5).
- c. Position the wood block between the axle tube and frame according to table below. Block height is dependent upon suspension ride height and/or axle brake size.

| AIR SUSPENSION RIDE HEIGHT AND BLOCK | | |
|--------------------------------------|-------------|--------------|
| Brake Size | Ride Height | Block Height |
| 16-1/2" Dia. | 5.5" | 5" |

- d. Lower the trailer by exhausting air from the air springs by moving the control arm to the "down" position (about 45°) until the axle tube is resting on the block.
- e. Check the ride height to make sure it is correct. Consult Landoll Service Center if correct height cannot be obtained.
- f. Loosen the 1/4" adjusting lock nut located on the adjusting block, allowing the control arm to move approximately 1 inch. Move the adjusting block until holes align, then insert locating pin. **(See Figure 4-5).**
- g. Align the control arm linkage to the control arm lower bracket and re-tighten the 1/4" adjusting lock nut to 2-4 ft.lbs. The ride height valve should now be correctly adjusted.
- h. Remove the locating pin.
- i. The block can now be removed by using the height control valve as an improvised jack by disconnecting the control arm at the lower bracket and pushing the control arm to an "up" position.
- j. Remove the block and reconnect the linkage. This allows the Automatic Height Control Valve to resume normal operation.
- k. Check the air ride height. If necessary, go through the adjustment procedure again until the proper air ride height is achieved.
- l. Check the air ride height periodically and adjust as needed.

4-7 ALIGNMENT

4-7.1 Wheel Alignment

| |
|---|
|  DANGER |
| TO PREVENT A LIFE THREATENING ACCIDENT: |
| 1. SUPPORT TRAILER AND UNDERCARRIAGE SO TIRES ARE OFF THE GROUND. |
| 2. SUPPORT THE TRAILER AND UNDERCARRIAGE ON JACK STANDS WITH SUFFICIENT CAPACITY TO SUPPORT THE TOTAL WEIGHT OF THE TRAILER AND ANY LOAD WHICH IT MAY BE CARRYING. |

When trailer tires show signs of scuffing, feather-edging or uneven wear, examine the trailer for damaged suspension (frame, shocks, linkage, etc.), axle, wheel bearings and wheels. Proper wheel alignment and wheel bearing adjustment is essential for proper tire wear. The simplest form of checking wheel alignment "toe" is by running the trailer over a "SCUFF GAUGE". A scuff gauge reading of 16 feet or less per mile is considered satisfactory. If a scuff gauge is not readily available, or edge wear on one side of a tire is occurring signifying positive or negative camber, alignment can be checked as follows:

- a. Remove wheel, hub and bearing assemblies.
- b. Place a 3-point axle gauge against the front side of the axle, and adjust each axle gauge point to the axle. (Double point end against the inner and outer wheel bearing surfaces of the spindle being checked and the other point on the inner bearing surface on the other spindle.) **(See Figure 4-7).**
- c. Move the axle gauge and place against the back side of the axle. If either of the points of double point end fails to touch the axle surface, a bent spindle is evident. A point gap of .015" or more is considered excessive tire "toe" and the axle must be replaced **(See Figure 4-7).**

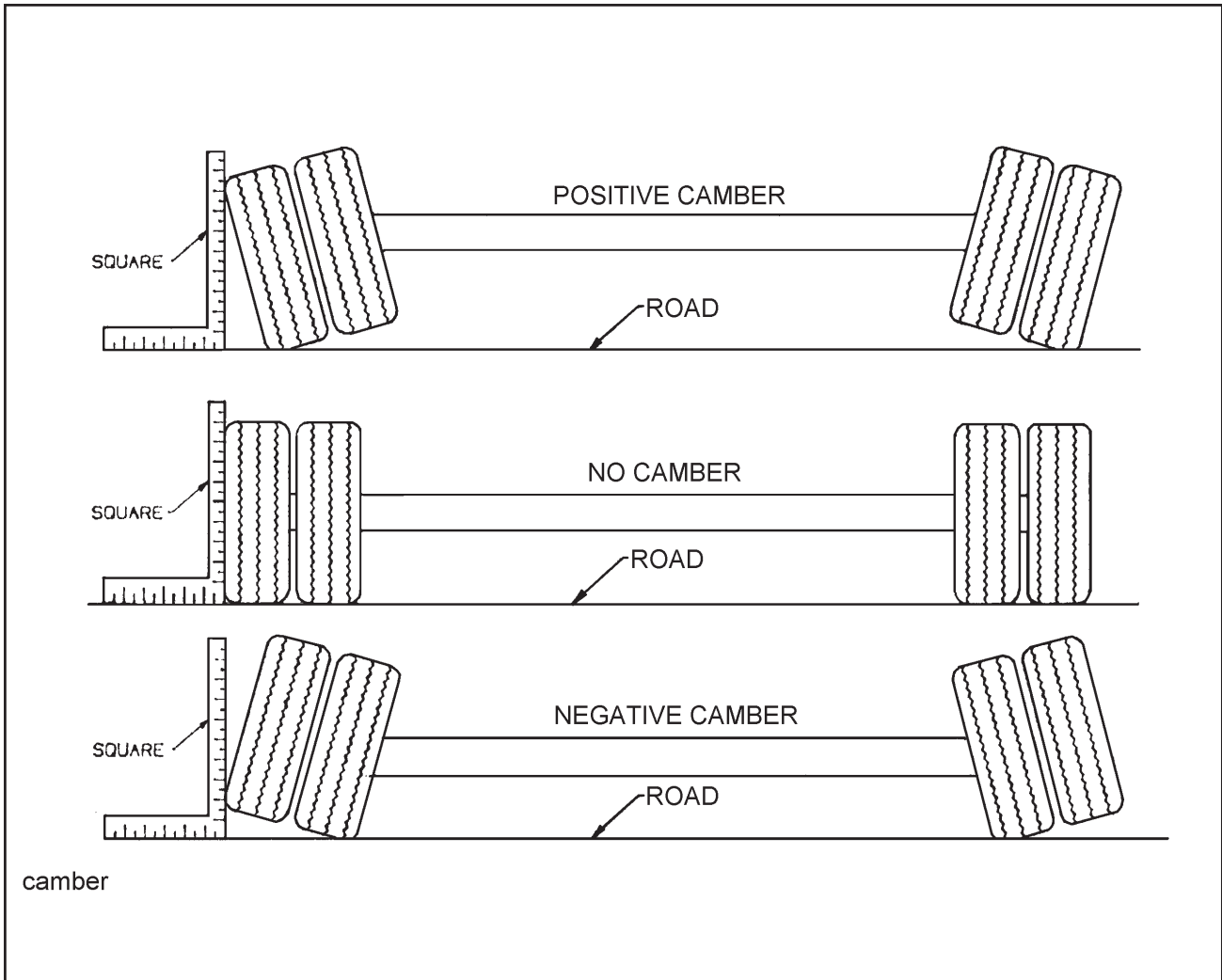

Figure 4-6 Examples of Camber

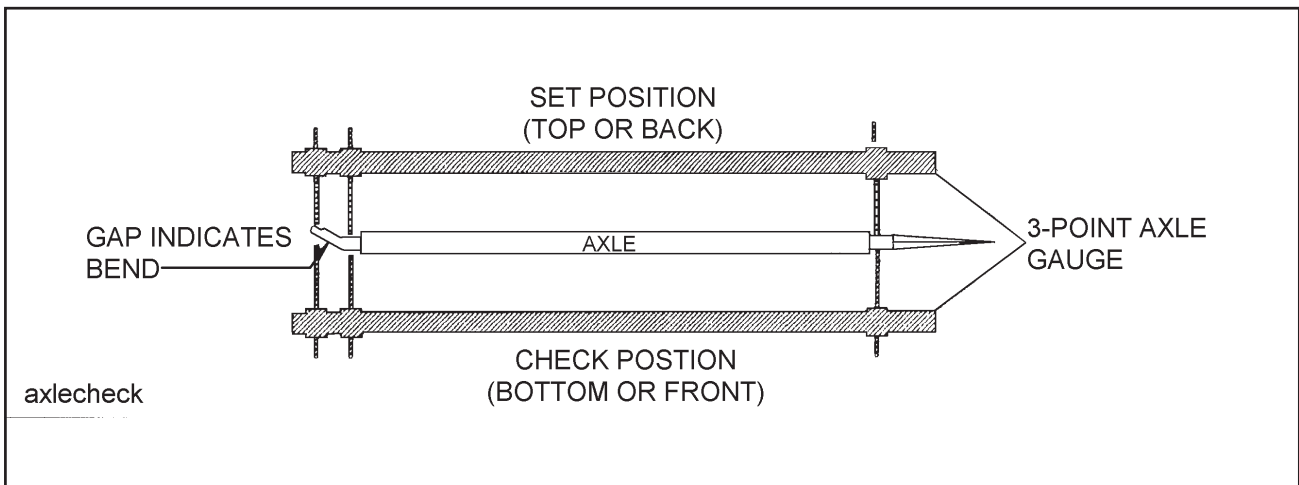

Figure 4-7 Checking Axle for Bend

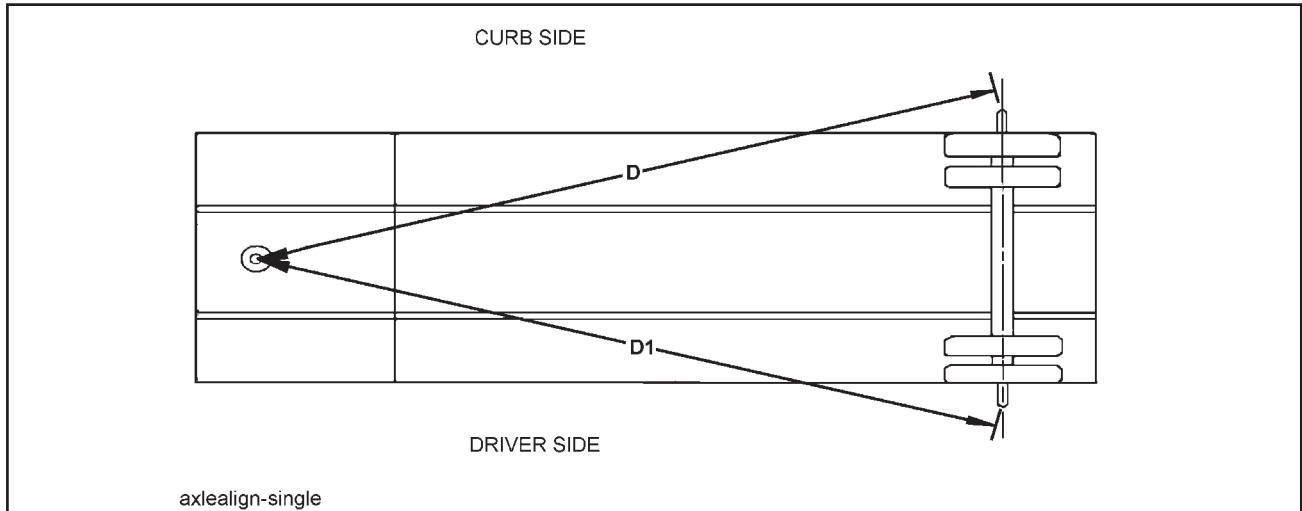

Figure 4-8 Checking Axle Alignment

- d. Follow the same procedures as in **Section 4-7.1 b. and c.**, except place the axle gauge above and below the axle. If gauge point gap is found, the axle has positive or negative camber. The trailer axle has no camber from the factory. If it is found to have positive or negative camber, axle replacement is necessary (**See Figure 4-6** for examples of camber).

4-7.2 Axle Alignment

Proper axle to king pin alignment is necessary to obtain straight tracking. If axle alignment is off, "dog-tracking" occurs. Check alignment manually or by using a semitrailer alignment machine. In either case, a thorough inspection of the complete suspension must be performed and all defects corrected before aligning.

a. Manual Alignment Procedure

1. Position semitrailer on a firm and level surface. Insure that the undercarriage is in the rear most position. Eliminate any suspension binding due to sharp turns or unusual maneuvers.
2. Detach tractor from the semitrailer and jack the trailer up sufficiently to permit measuring from the underside of the trailer.
3. Suspend a plumb bob at axle height from the center of the king pin.

4. Measure (D) from the plumb bob to the center point on one end of the axle. Record this measurement (**See Figure 4-8**).
5. Measure (D1) to the other end of the axle in the same manner as in **Step 4**. Record this measurement (**See Figure 4-8**).
6. Set D about 1/8" shorter than D1 to insure proper trailer tracking on slope of road.
7. The suspensions must be in good repair with no binding or other restrictions before aligning. All defective parts of the suspension or axles must be replaced immediately.

b. Air Ride Suspension Axles

The air ride suspension is aligned and adjusted at the factory and it should not be necessary to align the axles. If, however it does become necessary to align the axles, the procedure is as follows:

1. To align air ride suspension axles, locate the front axle equalizer beam pivot bolt in front hanger at front end of lock nut. Rotate the head of the pivot bolt. For axle alignment forward, rotate bolt head clockwise. For axle alignment rearward, rotate the bolt head counter-clockwise. Loosen the suspension pivot bolt lock nut.
2. Align the axle using the method outlined in **Section 4-7.2 a.c.**
3. After proper alignment has been obtained, tighten the suspension pivot bolt nut to the torque listed in the table in **Section 4-6.2**.

c. Spring Suspension Axles

| SPRING SUSPENSION TORQUE CHART | | | | |
|--------------------------------|---------|------|-------------|-------|
| Size | 1" | 7/8" | 7/8" U-bolt | 1/2" |
| Torque in Ft.Lbs. | 480-500 | 250 | 300 | 55-60 |

1. Loosen the torque arm clamp bolts on the adjustable torque arms and loosen the axle U-bolts.
2. Turn the adjustable torque arm on the front axle until the proper alignment has been achieved using the procedure outlined in **Section 4-7.2 a.c.**
3. Tighten the axle U-bolts to the torques listed in the above table.
4. Tighten the front axle torque arm clamp bolts to the torque listed in the above table.

4-8 BRAKE SYSTEM MAINTENANCE

! WARNING

USE GREAT CARE IF WHEELS OR BRAKE DRUMS MUST BE HANDLED. THEY MAY BE VERY HOT AND CAN CAUSE SERIOUS INJURY.

4-8.1 General

- a. Check air hoses for chafing, bends, kinks, or damaged fittings. Replace defective hoses.
- b. Check the brake system for loose, missing, deformed, or corroded fastenings. Replace and tighten defective hardware.
- c. Check brake linings for excessive wear or distortion.
- d. Drain air reservoir daily. A drain cock on the bottom of each air reservoir vents the tank to drain collected water and oil. If held open, air pressure in the tanks is relieved, causing the emergency or parking brakes to be applied (**See Figure 4-9**).

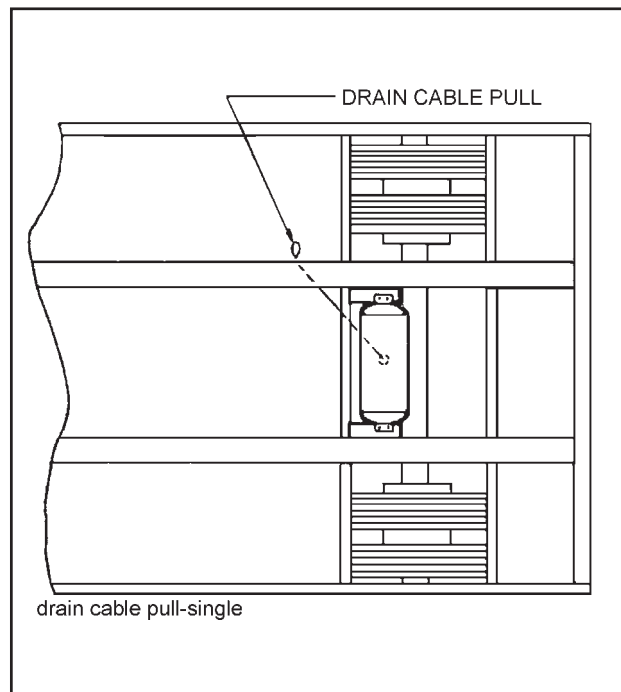

Figure 4-9 Drain Cock Locations

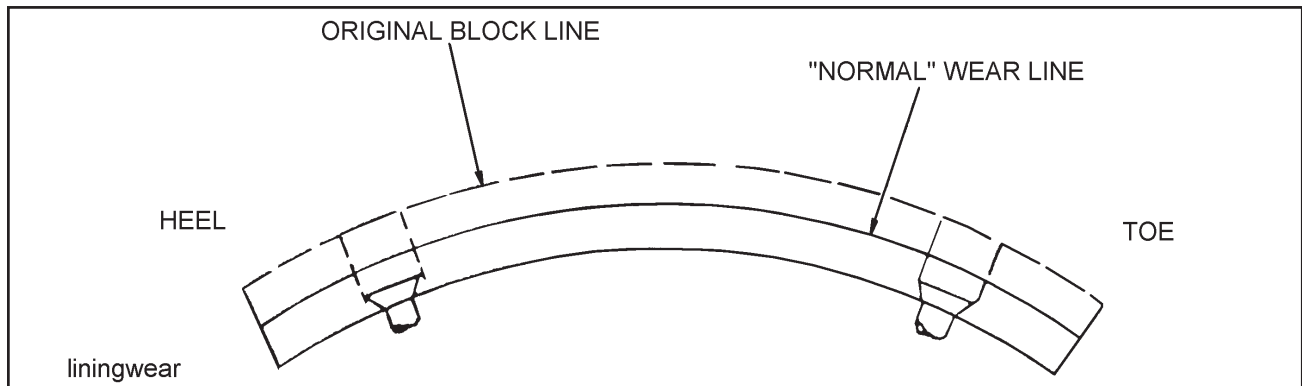

Figure 4-10 Brake Lining Wear

4-8.2 Spring Air Brake Chamber

Repair or replace faulty units. Check the condensation holes on the underside of the brake chambers to make sure they are open. The spring brake has two brake chambers, a service chamber and an emergency chamber or spring chamber. Service brake chambers should be disassembled and cleaned at 50,000 miles or yearly. The diaphragm and any marginal parts should be replaced. The spring chamber should not be serviced. Replace entire unit if spring chamber becomes faulty. When replacing the service diaphragm, replace the corresponding parts for the other chamber on the same axle (to aid in even brake application and release). Examine yoke pin for wear and replace as necessary.

⚠ WARNING

THE SPRING BRAKE CHAMBER EMPLOYS A SPRING WITH HIGH FORCES. SERVICE SHOULD NOT BE ATTEMPTED. SERIOUS INJURY OR DEATH MAY RESULT.

a. Caging the Power Spring

1. Chock the semitrailer wheels.
2. Remove dust cap from spring brake chamber.
3. Remove the release bolt from its holding brackets and insert it into the spring brake chamber. **DO NOT USE AN IMPACT WRENCH TO CAGE THE SPRING BRAKE!**
4. Turn the bolt until the spring brake is caged. This should be 2-1/4 to 2-1/2 inches of release bolt extension.
5. The brakes should now be released. Do not operate loaded semitrailer with brake manually released.

6. To reset the spring brake, turn the release bolt until the spring is released. Remove the release bolt and store it in its brackets.
7. Snap the dust cap back in place on the chamber.

b. Removal

1. Chock all tractor and semitrailer wheels and drain the air system.
2. Mark the brake chamber for proper air line port alignment for reassembly.
3. **CAGE THE POWER SPRING** following the steps outlined in **Section 4-8.2 a.**
4. Disconnect the slack adjuster from the connecting rod by removing the clevis pin (**See Figure 4-12**).
5. Mark all air service lines for proper re-installation and disconnect from the brake chamber.
6. Remove the brake chamber from the axle brackets.

c. Installation

1. **CAGE THE POWER SPRING** following the steps outlined in **Section 4-8.2 a.**
2. Position the inlet ports by loosening the service chamber clamp bands and rotating the center housing so the ports align with marks made during disassembly. Then re-tighten the clamp bands.
3. Loosen the clamp bands on the spring brake chamber and rotate the chamber housing until the breather hole faces downward. Re-tighten the clamp bands.
4. Remount the brake chamber on the axle brackets and reconnect the air service hoses and the slack adjuster connecting rod (**See Figure 4-12**).

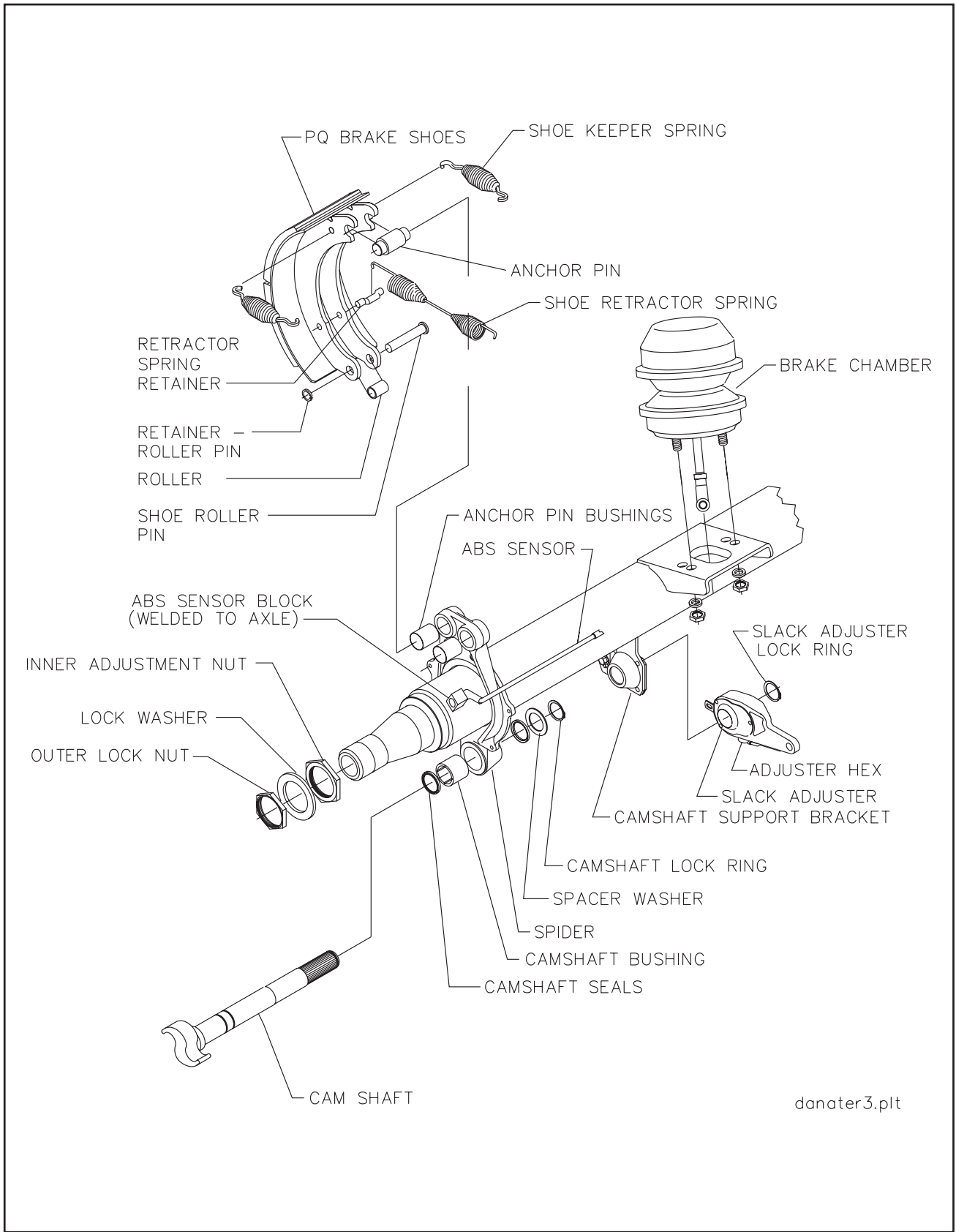

Figure 4-11 Axle and Brake Assembly

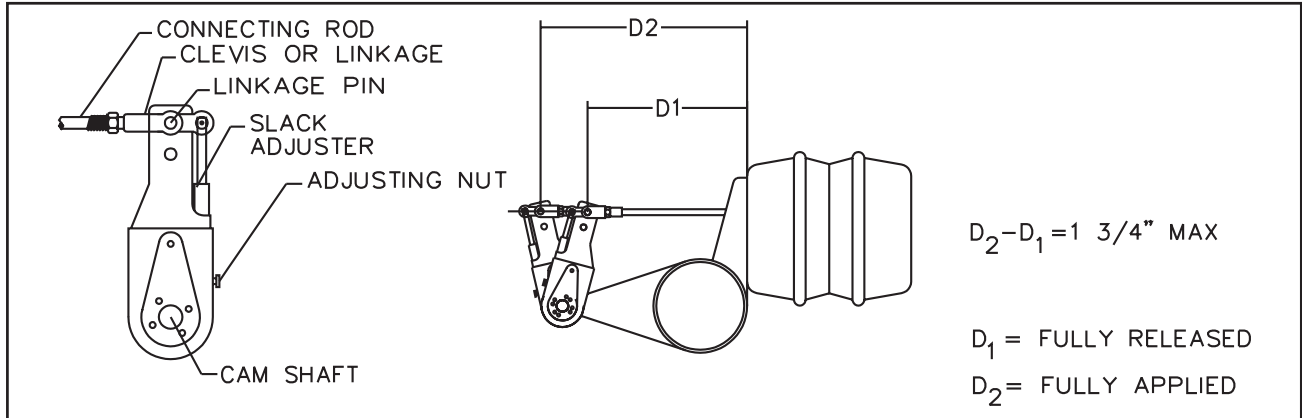

Figure 4-12 Checking Brake Adjustment

IMPORTANT

BE SURE THE SERVICE LINE IS ON THE SERVICE CHAMBER PORT AND THE EMERGENCY LINE IS ON THE SPRING BRAKE PORT.

- d. Check for leakage by charging the air system to a minimum of 90 psi and applying soap suds to the brake chamber and connections. If a growing bubble is detected or bubbles are blown away, locate the source of the leak and repair.
- e. Insure that the clamp band is properly seated and tight **before** uncaging the power spring.

4-8.3 Relay Valve Maintenance

Every 3600 operating hours, 100,000 miles, or yearly, the Relay Emergency Valve should be disassembled, cleaned, and lubricated by a trained technician.

⚠ WARNING

REPAIR OR REPLACEMENT OF THE RELAY/EMERGENCY VALVE IS A COMPLEX OPERATION AND SHOULD BE PERFORMED BY TRAINED SERVICE PERSONNEL. CONTACT A LANDOLL AUTHORIZED SERVICE CENTER FOR SERVICING.

4-8.4 Brake Assembly Maintenance

The brake assemblies should be inspected and adjusted every 2,000 miles or monthly. Examine the brake linings visually to locate the lining showing the greatest amount of wear. The wheel and drum should be removed and the linings replaced if the thinnest portion of the lining is 3/8 in. (9.5 mm) or less. Do not allow the linings to wear thin enough that the lining rivet contacts the drum. (See Figure 4-10).

⚠ WARNING

DO NOT ALLOW GREASE TO CONTACT BRAKE LININGS AS THIS COULD RESULT IN REDUCED BRAKING PERFORMANCE.

- a. **Brake Adjustment** . Slack adjusters provide the means for routine brake adjustment to compensate for lining wear. Inspect and adjust slack adjusters weekly or at 2,000 mile intervals.
 1. To check adjustment release brakes.
 2. Measure the distance (D1) from the face of the brake air chamber to the center of the slack adjuster linkage pin (See Figure 4-12).
 3. Apply brakes.
 4. Repeat step 2 to measure the distance (D2).
 5. Subtract the two distances to find the air chamber push rod travel. The total travel of the brake push rod must be less than 1-3/4" to meet Federal "IN-SERVICE" criteria. It is advisable to adjust all brakes on the same axle to within 1/2" of each other to prevent unbalanced braking.

6. To adjust, release brakes.
 7. Place a 9/16" box end or socket wrench on the slack adjuster adjusting nut (**See Figure 4-12**), and push in on the locking sleeve.
 8. Adjust by rotating the adjusting nut counterclockwise to loosen the brake and clockwise to tighten the brake.
 9. Remeasure air chamber push rod travel from release to full brake application. If the adjustment is not within the "IN-SERVICE" criteria readjust. If the adjustment has brought the travel to within specifications, proceed to the next step.
 10. Remove wrench from slack adjuster. Check locking sleeve to verify that it has sprung back out and is locking the adjusting nut. If not, the adjuster will have to be rotated slightly.
- b. Disassembly (See Figure 4-11)**
1. Release brakes and back off slack adjuster.
 2. Remove slack adjuster lock ring and slack adjuster.
 3. Remove drum assembly.
 4. Disengage the roller retainers from the rollers.
 5. Press down on the bottom brake shoe and remove the lower cam roller. Lift the top shoe and take out the top cam roller.
 6. Lift out the shoe retractor spring, which is now free of tension.
 7. Swing the lower shoe back approximately 180° to relieve the tension on the shoe keeper springs. Remove the springs and slip the shoes off the anchor pins.

8. Remove camshaft lock ring, spacer washer(s) and camshaft.
9. After removing the shoes, completely inspect all brake components, servicing as necessary.

c. Reassembly

1. Install new anchor pin bushings, camshaft bushing, and camshaft seals into the spider.

IMPORTANT

WHEN INSTALLING CAMSHAFT SEALS, THE SEAL ON THE SLACK ADJUSTER SIDE IS INSTALLED FACING INTO THE SPIDER. THIS ALLOWS GREASE TO PURGE OUTSIDE THE BRAKE ASSEMBLY WHEN GREASING THE CAMSHAFT BUSHING.

2. Install cam roller, retainer clip and retractor spring retainers onto the brake shoes.
3. Install 1/8" thick camshaft washer onto the camshaft.
4. Install the cam shaft into the spider. Install spacer washer and lock ring retainer on camshaft before sliding the camshaft through the camshaft support bracket. Install the slack adjuster, washer, and lock ring retainer.
5. Install the brake keeper springs onto the shoes. Install shoes onto the spider by placing shoes in place on the anchor pins, then "wrap" the two shoes into place about the spider.
6. Install the shoe retractor spring onto the shoes.
7. Connect the slack adjuster to the brake chamber pushrod.
8. Adjust brakes as outlined in brake adjustment procedures.

4-9 HUB AND DRUM MAINTENANCE

4-9.1 Clean and inspect the brake drums whenever relining the brakes. To be suitable for further service, the brake drum should pass the following checks.

- a. The brake surface should be free of scoring, excessive heat checks and cracks.
- b. The brake surface diameter should be within the maximum diameter cast or stamped on the drum.
- c. The mounting holes and pilot must be round and true.
- d. The mounting surface must be clean and flat.

⚠ WARNING

FAILURE TO REPLACE FAULTY BRAKE DRUMS WILL RESULT IN AN UNRELIABLE BRAKING SYSTEM, AND MAY LEAD TO AN ACCIDENT.

4-9.2 It may be necessary to turn or resurface the braking surface to remove small heat checks or other surface defects resulting from normal use.

- a. The maximum diameter cast into the back plate portion of the brake drum is the maximum diameter or discard diameter to which the brake drum may be turned or worn and still be usable. If any portion of the brake surface exceeds the maximum diameter it must be discarded. The maximum is .120 over the nominal new diameter unless stated otherwise on the casting. The maximum diameter cast into the brake drum supersedes all published information.

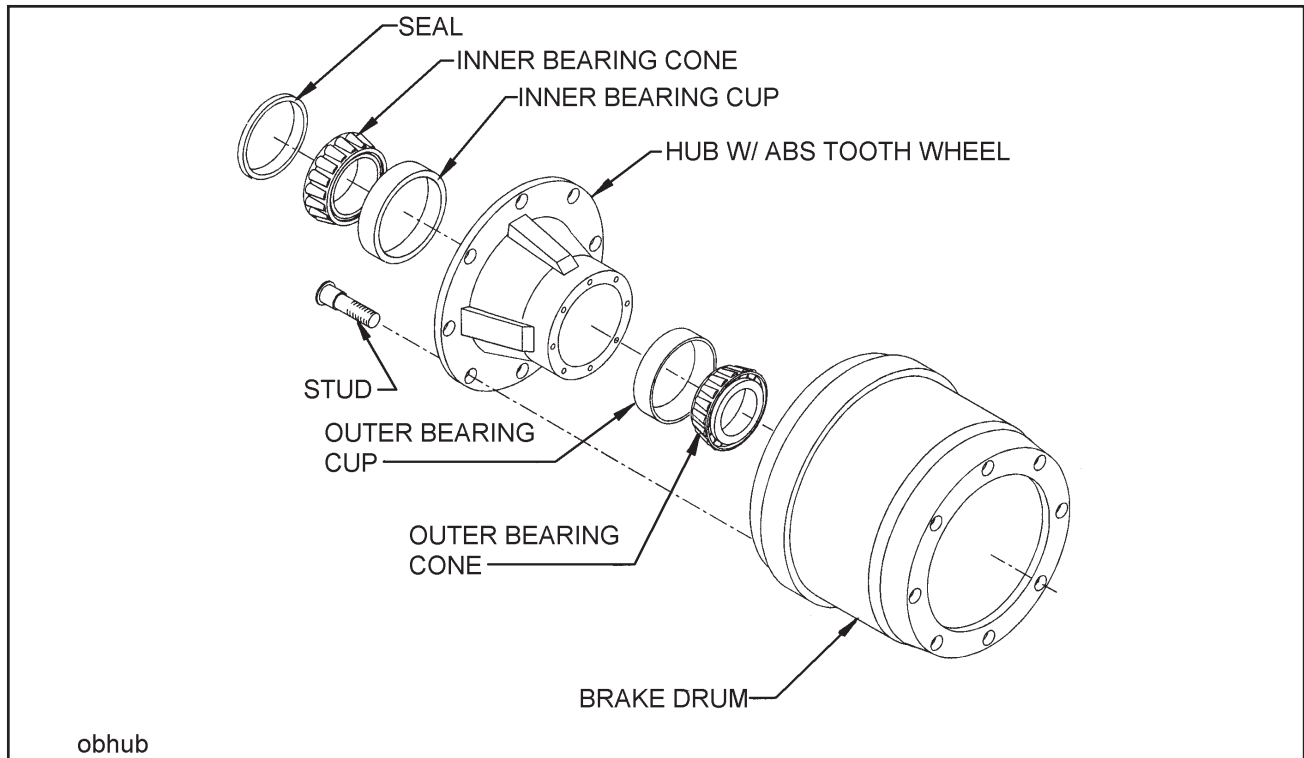

Figure 4-13 Outboard Mount Hub and Drum

- b. When resurfacing a drum, allow at least 0.040 inches under the maximum diameter for additional wear.

! WARNING

TURNING A BRAKE DRUM BEYOND 0.040 INCHES UNDER THE MAXIMUM DIAMETER WILL RESULT IN A WEAKER BRAKE DRUM AND MAY RESULT IN AN ACCIDENT.

- 4-9.3** Replacement of the brake drum is required if any of the following conditions exist:
- a. The brake drum is cracked.
 - b. The brake surface is heat checked, grooved or worn beyond the rebore limit or the maximum diameter.
 - c. The back plate is cracked.
 - d. The bolt holes are elongated.
 - e. The brake drum has been severely overheated.
 - f. The brake drum is out-of-round.

! CAUTION

REPLACE BRAKE DRUMS IN PAIRS TO ACHIEVE THE SAME BRAKING POWER ON BOTH WHEELS AND MAINTAIN AN EVEN BRAKING LOAD ON THE AXLE. FAILURE TO DO THIS MAY SIGNIFICANTLY REDUCE THE PERFORMANCE, SERVICE LIFE, AND/OR SAFETY OF YOUR VEHICLE.

- 4-9.4** Replace the hub and drum as follows **(See Figure 4-13):**

- a. Remove the brake drum **(See Figure 4-13)**. It may be necessary to release the slack adjuster.
- b. Remove hub cap and catch lubricant in a pan.
- c. Remove outer spindle nut, spindle locking washer, inner spindle nut, and bearing. Remove hub from axle.
- d. Using an appropriate driver, remove inner bearing cone, and seal.
- e. Using an appropriate driver, remove bearing cups from hub.
- f. Check that the hub cavity is clean. If the hub is to be reused, clean it thoroughly.
- g. Insert bearing cups into the hub.
- h. Clean the mounting surfaces with a good grade commercial cleaner and soft rag. Dry all component parts with a clean, absorbent cloth or paper. Lubricant will not adhere to surfaces wet with solvent.
- i. Install inner bearing, cone, and seal.

IMPORTANT

DO NOT MIX NEW CUPS WITH OLD CONES OR NEW CONES WITH OLD CUPS.

- j. Place the hub or wheel over the axle spindle being careful to align the hub bore with the axle. Do not damage the seal. Support the hub assembly until the outer bearing cone and spindle nut are installed, to avoid damaging the seal.
- k. Install the outer bearing cone and inner spindle nut, tightening the nut until it is snug against the outer bearing cone. Remove the hub support allowing the hub to rest on the bearings.
- l. Install and adjust bearings **(See Wheel Bearing Lubrication and Adjustment)**.
- m. Install the hub cap with the proper gasket. Tighten the cap screws of the hub cap to 15 to 20 ft-lbs. of torque.
- n. Remove the filler plug and fill the hub cavity to the recommended level with a gear type oil.
- o. Place the drum over the hub and brake shoes being careful not to damage the threads on the studs. Make sure the drum seats flat against the hub flange and mates properly with the hub pilot. There should be no interference between the brake drum pilot chamfer and the corner radius on the hub. If interference exists, the hub will not be able to function properly.

4-10 WHEEL BEARING LUBRICATION AND ADJUSTMENT

With semitrailer sitting level, the oil level must be checked daily and maintained between the "ADD" and "FULL" lines on the hub cap window. Check for cracked windows, missing filler plugs, and oil leaks. Add hub oil through the "POP-IN" filler plug located in the center of the hub windows. Re-install the "POP-IN" plugs after filling each hub. Adjust wheel bearings and change oil every 50,000 miles or with each brake lining replacement, whichever occurs first.

4-10.1 Adjustment

- a. With a drain pan under the hub cap, remove the hub cap assembly allowing oil to drain.
- b. Lift the wheel off of the ground.
- c. Adjust slack adjuster to eliminate brake drag during tire/wheel rotation.
- d. Remove outer lock nut and inner nut and lock washer.
- e. Tighten the inner adjustment nut to a minimum of 75 ft.-lbs., while rotating wheel to insure proper seating of the bearings and cups in the wheel hub.
- f. Loosen the inner adjustment nut so that the wheel will turn freely.
- g. Retighten the inner adjustment nut to 50 ft.-lbs. while rotating the wheel, to properly position the bearings for the final adjustment.
- h. Loosen the inner adjustment nut 1/3 turn.
- i. Install the spindle nut lock washer so that the dowel on the inner nut will align with a hole in the lock washer and the washer tang fits in the spindle keyway.
- j. Install the outer lock nut and tighten to 250-300 ft.-lbs. End-play of .001" to .010" must be present in the adjusted wheel bearing assembly.
- k. Install the hub cap with a new gasket and fill with oil to the full mark. Use 90 weight gear oil.
- l. Adjust brakes according to **Section 4-8.4 a.**
- m. Check hub oil level after the wheel has set level in one position for a few minutes to allow the oil to work into the bearings.

DANGER

FAILURE TO TORQUE THE OUTER LOCK NUT PROPERLY COULD CAUSE THE WHEEL TO COME OFF DURING VEHICLE OPERATION RESULTING IN PROPERTY DAMAGE OR LOSS OF LIFE.

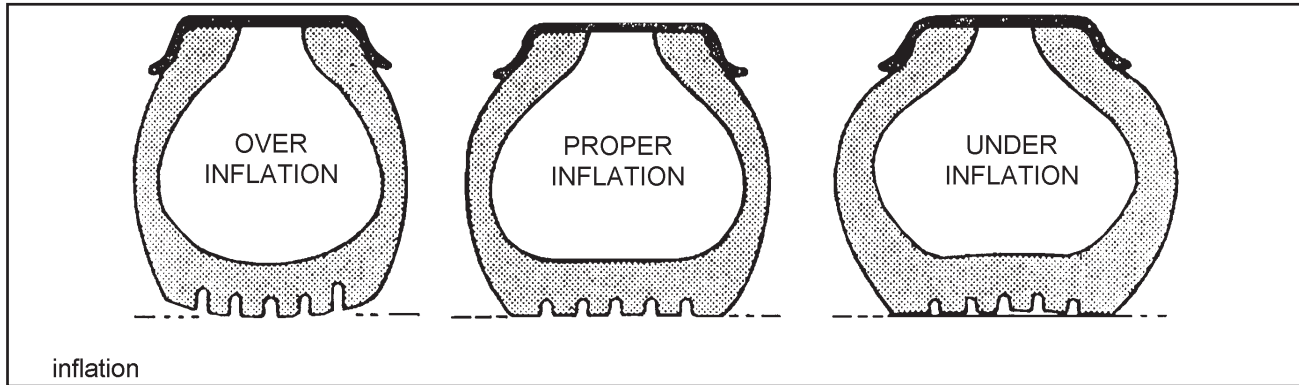

Fig. 4-14 Tire Inflation Examples

4-11 TIRE MAINTENANCE

4-11.1 Tire Inflation. Tire inflation will cause tire to ground contact characteristics as shown in **Figure 4-14**. Tire inflation should be checked daily while the tire is cold, and during road stops. Checking the tire pressures while tires are hot will give a faulty increased pressure reading. Adjusting tire air pressure to the specified amount while tires are hot will produce improper tire to road contact and thus abnormal wear. Do not exceed cold inflation pressure listed on the semitrailer VIN plate located on the front of the semitrailer. Exceeding cold inflation pressure will result in damaged tire bodies, rims, and wheels. Replace all valve stem caps when pressure checking/adjusting has been completed. Remove any foreign objects from between duals.

4-11.2 Tire Matching. Both tires on the same spindle must be the same size in order to properly distribute the load and braking forces between them. The tire must be mounted on a rim and properly inflated before measuring. If there is an allowable difference in size the smaller tire should be mounted to the inside position of the duals.

a. Tape Measuring Method: Measure around each tire on the tread surface. A maximum difference of 3/4" is allowed between the two mating tires of a dual (**See Figure 4-15**).

b. Straight Edge or String Method: (This method can not be used if tire and wheel assemblies are not mounted on the axle.) Jack semitrailer up until the wheels are off of the ground. Hold a straight edge against the tires of both ends of an axle. A gap at one tire indicates a smaller tire. A maximum of 1/8" gap is allowed (**See Figure 4-16**).

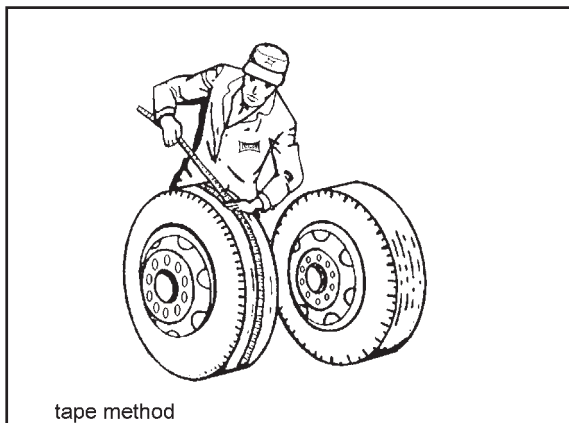

tape method

Fig. 4-15 Measuring Tape Method

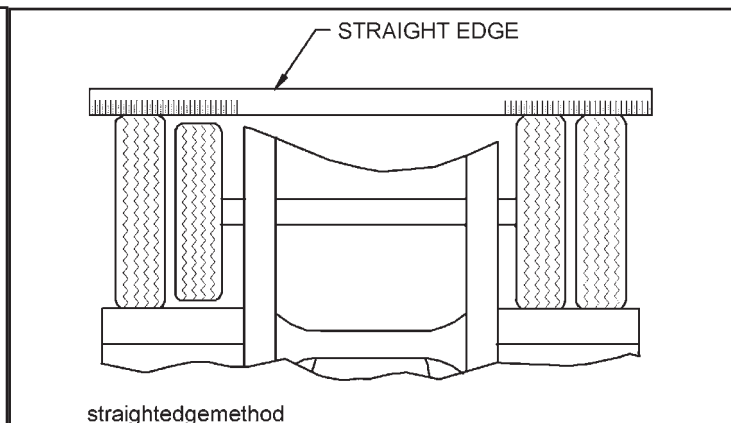

straightedgemethod

Fig. 4-16 Straight Edge Method

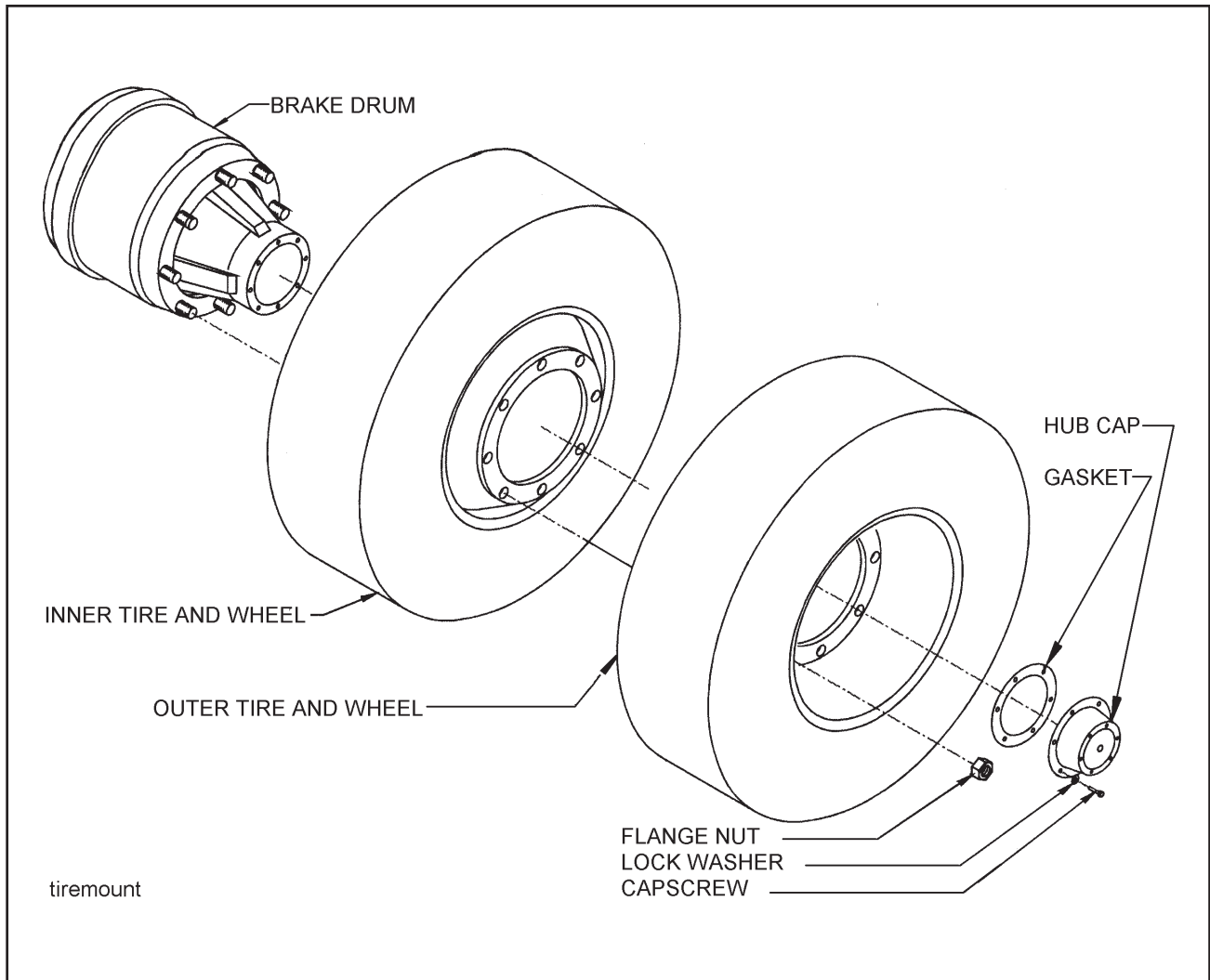

Figure 4-17 Mounting Tires and Wheels

4-11.3 Tire Removal from Trailer

- a. Tires need to be off the ground to provide enough clearance to remove tires from trailer. Place block under approach plate. Tilt trailer until tires come off the ground.

4-11.4 Mounting Tire and Wheel

- a. Make sure that all mounting surfaces are clean and free of rust, dirt or paint. A wire brush may be used to clean these surfaces (See Figure 4-17).
- b. Position the inner disc wheel over the studs, being careful not to damage the stud threads. Make sure that the disc wheel is flat against the mounting surface and that there is clearance between the disc wheel taper and brake drum.
- c. Install the inner capnuts on the studs and tighten to fifty foot-pounds using the sequence illustrated in Figure 4-18. Make certain that the left-handed threads are installed on the driver side of the vehicle and the right-handed threads are installed on the curbside of the vehicle.
- d. Tighten the inner capnuts to full torque of 450 to 500 foot-pounds using the sequence shown in Figure 4-18.
- e. Position the outer disc wheel over the capnuts being careful not to damage the inner capnut threads. Be sure the valve stems for both the inner and outer tire are accessible.

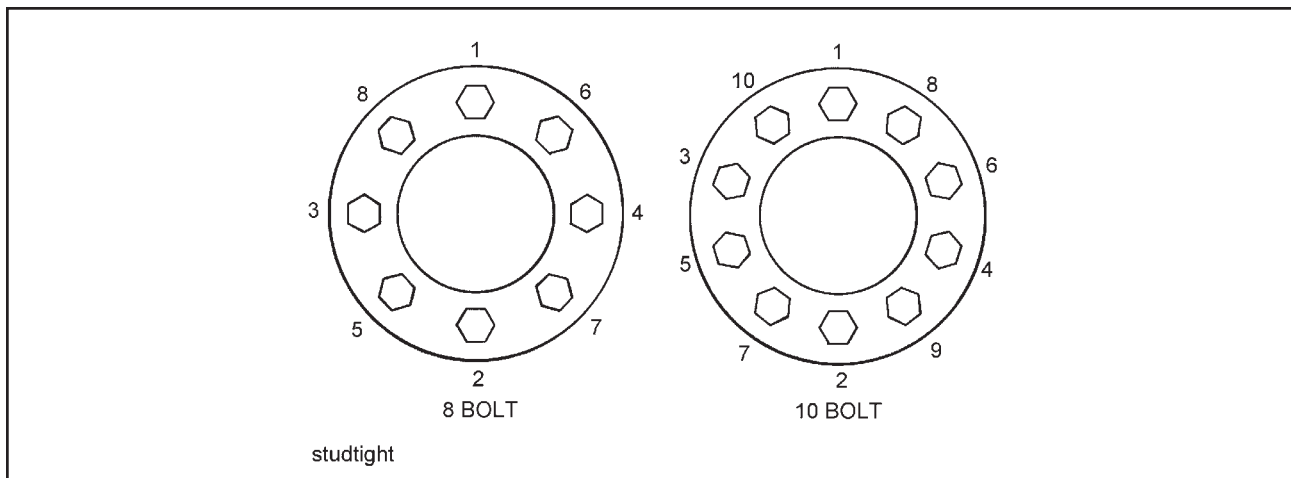



Figure 4-18 Stud Tightening Sequence

- f. Install the outer capnuts and tighten to 50 foot-pounds using the sequence in **Figure 4-18**. Then tighten to full torque of 450 to 500 foot-pounds using the same sequence.
- g. Torque will drop after the first 50 to 100 miles of operation. Check the capnuts for proper torque after this interval and retighten them. Loosen the outer capnuts and retighten the inner and outer capnuts per **steps d. to f.**

| |
|--|
|  WARNING |
| <p>USE A TORQUE WRENCH TO ASSURE PROPER TORQUE. INSUFFICIENT TORQUE CAN CAUSE STUD BREAKAGE AND DAMAGE WHEEL PILOTS. OVERTORQUE CAN OVERSTRESS THE STUDS AND STRIP THE THREADS.</p> |

4-12 GEARBOX MAINTENANCE

- 4-12.1** Inspect the gearbox chain before and after usage.
- 4-12.2** If the chain is loose, it needs to be tightened before loading a load. This is done up at the gearbox.
 - a. Loosen the four screws that hold gearbox to the mounting plate.
 - b. Pull the gearbox forward using the adjusting screws.

- c. Do not put more than 12,000 pounds of pull on the gearbox so each screw should have no more than 6,000 pounds of pull on it. Torque of 90 ft.-lbs on 7/8-9 non-oiled, clean thread should create 6,000 pounds tension.
- 4-12.3** If the gearbox chain has more than 1/32" wear in the links, the chain needs to be replaced. If the chain needs to be replaced or if links need to be taken out in order to get the chain tight, one of the chain links will need to be cut and welded back together. A chain splice p/n 129214 is used to aid in splicing the chain back together. Use stainless steel missile rod (Welco Super Missile Weld 120,000 psi tensile strength) to weld the link back together.

4-13 HYDRAULIC ENGINE PACKAGE

The hydraulic engine package should be inspected weekly to insure continued proper operation. The inspection should include:

- 4-13.1** Check the hydraulic oil level weekly, or after any leakage. See **Table 4-1** for proper hydraulic oil. With all hydraulic cylinders in the retracted position and with the engine stopped, check the hydraulic oil level.
- 4-13.2** Check hoses weekly for cracks or leaks. If a valve or line leaks, it should be replaced immediately.
- 4-13.3** Check the engine oil each time before using. Oil level should be maintained between the "ADD" and "FULL" marks on the oil dip stick. For further maintenance procedures and proper lubrication specifications, please refer to the engine owner's manual that was supplied with the hydraulic engine package.
- 4-13.4** Replace hydraulic filter with new filter at least every 6 months or more often under adverse conditions.
- 4-13.5** Use the fuel recommended for the engine package installed on you trailer.

Troubleshooting should be performed by a trained technician. Landoll Corporation is not responsible for equipment that is improperly maintained. Contact an authorized Landoll Service center for servicing.

5-1 ELECTRICAL

Most electrical system problems show up as a burned out light or fuse, or inoperative electrical component. Wiring, grounds, or components may be at fault. Locate the symptom in this section that best identifies your electrical problem. Check out each possible problem under that symptom. If the problem cannot be located, see an automotive electrical specialist. For maintenance procedures, see **Section 4-5**.

SYMPTOM

PROBLEM: REMEDY

NO LIGHTS

Fuse blown: replace fuse.

Connection at plug-in: tighten connection.

Broken or corroded wires: replace wire.

Ground wire loose: clean and tighten ground.

Dirty or corroded 7-way connector or receptacle: Clean w/ wire brush or replace connector or receptacle.

LIGHTS FLICKERING

Wires shorted or loose: locate, insulate, replace, or tighten.

LIGHTS DIM

Voltage difference between trailer & tractor: tractor supply wire or circuit components are too low a capacity. - Enlarge wire or component. Match bulbs with tractor voltage.

LIGHTS BRIGHT & BURN OUT

Ground wire disconnected: connect ground wire.

Voltage difference between trailer & tractor: tractor supply wire or circuit components are too low a capacity. - Enlarge wire or component. Match bulbs with tractor voltage.

FUSE BLOW-OUT OR CIRCUIT BREAKER TRIPPING

Vibration: locate source of vibration and repair.

Short circuit: replace fuse and try all accessories. If fuse blows right away, locate short and repair.

LAMP BULB BURN OUT

Vibration: locate source of vibration and repair.

Short circuit: replace fuse and try all accessories. If fuse blows right away, locate short and repair.

Loose connection: check lamp sockets and ground connections.

Intermittent short: locate short and repair.

Improper voltage: check voltage regulator output.

5-2 TIRES - WHEELS - SUSPENSION

Most tire, wheel, and suspension related problems are due to excessive loads, extreme conditions, and improper maintenance. Tire, wheel, and suspension problems can be easily detected and solved by checking the following guide. For maintenance procedures, see **Sections 4-6, 4-9, 4-10, and 4-11.**

SYMPTOM

VIBRATIONS WHILE DRIVING

PROBLEM: REMEDY

Improper tire inflation: inflate to proper pressure.
Tires cupped or have flat spots: replace tires.
Wheels bent or loose: replace or tighten.
Tires incorrectly mounted: remount.
Mud in wheels: clean wheels.
Tire(s) out of balance: balance tires.
Brakes dragging: locate cause and repair.
Object(s) stuck between duals: remove object(s).

RAPID TIRE WEAR/DETERIORATION:

CENTER TREAD WEAR

Over inflation: deflate to correct inflation.

SHOULDER TREAD WEAR - BOTH SHOULDERS

Under inflation: increase inflation to correct PSI. Check axle alignment.
Overloading: loads are above rated tire capacity. DO NOT load above rated tire capacity.

SHOULDER TREAD WEAR - ONE SHOULDER

Axle damage: straighten or replace axle.
Axles not parallel: check axle alignment.

OVERALL TREAD WEAR

Overloading: check tire load rating.
High speeds: adjust speed according to road and load conditions.
Incorrect dual matching: properly match dual tires.

TIRE FLAT SPOTS

Quick stops: adjust braking practices.
Grabbing brakes: adjust brakes properly.
Worn or loose wheel bearings: adjust or replace as needed.
Out of balance wheels and tire: balance wheels and tires.
Check ABS system function.

UNEVEN WEAR

Suspension bushings worn: replace bushings.
Worn or loose wheel bearings: adjust or replace as needed.
Out of balance wheels and tires: balance wheels and tires.

RIM FAILURE*:

CRACKING

Overinflated tires: deflate tire to proper PSI.
High speeds: adjust speed according to road and load conditions.
High speed cornering: adjust cornering practices.
Overloading: check rim load rating.

***IN ALL INSTANCES OF RIM FAILURE, REPLACE THE RIM IMMEDIATELY!**

TIRES - WHEELS - SUSPENSION (CONTINUED)

SYMPTOMS

BENDING OR WARPING

PROBLEM: REMEDY

Curb-hopping or potholes: adjust turning practices and adjust speed accordingly with road conditions.

Improper tightening sequence: follow proper tightening sequence. (See Figure 4-.)

BROKEN STUDS*

Over tightening: use correct torque when mounting.

Under torque: Use correct torque and tightening sequence when mounting.

Rim not seated: Adjust rim to equal distance with hub.

*REPLACE BROKEN STUDS BEFORE USING THE SEMITRAILER!

SEMITRAILER TRACKING PROBLEMS:

TRACKS TO ONE SIDE

Axle alignment: re-align axle.

TRACKS TO EITHER SIDE

Broken or bent springs or equalizers: replace defective parts.

Axles not parallel: realign axles

AIR RIDE HEIGHT PROBLEMS:

TOO HIGH

Axle to control valve linkage: readjust linkage.

Height Control Valve internal leak: repair or replace valve.

TOO LOW

Axle to control valve linkage: readjust linkage.

Height Control Valve filter plugged: clean or replace valve.

Pressure Protection Valve filter plugged: clean or replace valve.

System air pressure low (65 PSI minimum required): troubleshoot air supply.

UNEVEN FROM SIDE TO SIDE

Linkage adjustment: readjust linkage.

Exhaust port plugged: clean or replace valve(s).

Height control valve internal leak: repair or replace valve.

Supply line to one height control valve pinched, restricted, or plugged: repair or replace line.

5-3 BRAKES

For maintenance procedures, see **Sections 4-8.**

SYMPTOM

NO BRAKES OR BRAKES
ARE INTERMITTENT

PROBLEM: REMEDY

Brake air system improperly connected: reconnect gladhands properly.

Relay/Emergency valve plugged: clean valve.

Defective tractor protection valve: repair or replace.

Restricted tubing or hose line: locate and eliminate restriction.

Broken line: locate break and repair.

Tractor air system failure: troubleshoot tractor air system and repair. Check ABS system function.

BRAKES (CONTINUED)

SYMPTOM

PROBLEM: REMEDY

SINGLE BRAKE DRAGGING
OR LOCKED

Broken internal brake component: locate and replace broken part.

Flat spot on cam roller or cam shaft: replace and lubricate.

Improper adjustment: adjust slack adjusters.

Spider bushing or cam bracket bushing binding: lubricate or replace bushing.

Improper lubrication: lubricate per **Figure 4-1**.

Worn brake shoe bushing: replace bushing.

Brake drum distortion: replace drum.

Broken brake chamber spring: replace spring.

Brake chamber pushrod binding: re-align brake chamber bracket.

Air brake line loose or broken: tighten or repair.

UNEVEN BRAKES

See “**SINGLE BRAKE DRAGGING OR LOCKED**”

Restriction in hose: locate restriction and remove.

Worn brake linings: reline brakes.

Grease on linings: reline brakes.

Broken slack adjuster: replace slack adjuster.

Call Factory or see qualified Trailer/Brake Technician.

Leaking brake chamber diaphragm: replace diaphragm.

BRAKES APPLY TOO SLOWLY

Brakes need adjusting or lubrication: adjust or lubricate as needed.

Low air pressure in brake system (below 90 PSI): check tractor air system.

Restricted tubing or hose: locate restriction and remove.

Defective relay valve: clean or replace.

Call Factory or see qualified Trailer/Brake Technician

BRAKES RELEASE TOO SLOWLY

Brakes need adjusting or lubrication: adjust or lubricate as needed.

Brake rigging binding: align brakes or replace bent parts.

Exhaust port of relay valve restricted or plugged: clean or replace valve.

Air lines kinked: Straighten air lines.

ALL BRAKES DO NOT RELEASE

Air system improperly connected to tractor: tighten or adjust connections.

Brake valve on tractor is applied: release brake.

Relay emergency valve in emergency position: check line pressure and check valve.

Restricted tubing or line: locate restriction and remove.

Defective tractor protection valve: troubleshoot tractor air system.

Parking brakes locked: troubleshoot air system.

Moisture in air system: Check air system

BRAKES (CONTINUED)

SYMPTOM

PROBLEM: REMEDY

INSUFFICIENT BRAKES

Brakes need adjusting: adjust brakes.
Brakes need lubricating: lubricate brakes.
Brakes need relining: reline brakes.
Low air pressure: troubleshoot air system.
Defective relay emergency valve: repair or replace.
Brakes overheated: stop and allow brakes to cool, locate cause of overheating.

BRAKES GRABBING

Grease on brake linings: reline brakes.
Brake rigging binding: align brakes or replace bent parts.
Defective brake valve on tractor: repair or replace valve.
Defective relay emergency valve: repair or replace valve.

EXCESSIVE LEAKAGE WITH
BRAKES RELEASED

Relay emergency valve leaking: repair or replace valve.
Leaking tubing or hose: replace defective part.

EXCESSIVE LEAKAGE WITH
BRAKES APPLIED

Relay emergency valve leaking: repair or replace valve.
Leaking brake chamber diaphragm: replace diaphragm.
Call Factory or see qualified Trailer/Brake Technician
Leaking tubing or hose: replace defective part.

EXCESSIVE LEAKAGE WITH
EMERGENCY SYSTEM ONLY
APPLIED - NO LEAKAGE WITH
NORMAL BRAKING

Defective relay emergency valve: repair or replace valve.

EXCESSIVE WATER PRESENT IN
BRAKE SYSTEM

Reservoir not drained often enough: drain reservoir daily.

EXCESSIVE OIL PRESENT IN
BRAKE SYSTEM

Compressor on tractor passing excessive oil: repair compressor.

BRAKE WILL NOT APPLY
PROPERLY

Flat spot on cam roller or camshaft: replace and lubricate.

BRAKES WILL NOT APPLY
WHEN EMERGENCY LINE IS
DISCONNECTED

Initial air pressure too low: allow air system to build up to minimum 90 PSI and stabilize.
Defective relay valve: repair or replace valve.
Air line leak: locate leak and repair.
Brake chamber leak: locate leak and repair or replace.

ABS WARNING LIGHT STAYS
ON

Refer to Rockwell WABCO ABS maintenance manual supplied with semitrailer, for system function and use of blink code diagnostics.

5-4 BRAKE DRUMS

For maintenance procedures, see **See Sections 4-8.**

SYMPTOM

PROBLEM: REMEDY

EXCESSIVE LOSS OF BRAKES
OR FADING

Overheated brake drums: check for defective or misadjusted brake linings, distorted or over-machined drums. Also check for operating conditions or loads that create severe or excessive brake applications.

BRAKES PULL TO EITHER SIDE

Drums of different diameters: replace with drums of same diameter.

Foreign matter in drums: clean drums out.

ROUGH OR NOISY BRAKING ACTION

Defective drums: pull drums and inspect for any of the following; Heat spotted drums, grease spotting, blue drums, scored drums, excessive wear at rivet holes or edges, polished drums, out of round drums, unbalanced drums, worn/damaged brake components, foreign matter in drums. Correct situation or replace defective part(s).

VIBRATION IN RIDE

Defective drums or out-of-round: replace drums.

Out-of-balance drums: balance drums.

5-5 HYDRAULIC SYSTEM

Most hydraulic system failures follow the same pattern: a gradual or sudden loss of pressure or flow with a resulting loss of cylinder or motor power. Any one of the system's components may be at fault. By following step-by-step procedures, the trouble can be located in a short time.

SYMPTOM

PROBLEM: REMEDY

SEMITRAILER LOCKED IN
TILTED POSITION

Velocity fuse activated: raise the trailer slightly (to reset the velocity fuse), then lower the trailer slowly.

SYSTEM INOPERATIVE

Not enough oil in system: fill, check for leaks.

Wrong oil in system: change oil, see specifications.

Filter dirty or clogged: drain oil and replace filter.

Hydraulic lines dirty or collapsed: clean or replace as necessary.

Air leaks in pump suction line: repair or replace as necessary.

Worn or dirty pump: clean, repair or replace. Check for contaminated oil. Drain and flush.

Badly worn components: examine for internal leakage. Replace faulty components. Check for cause of wear.

Leakage: check all components, and relief valve for proper settings.

Excessive load: check unit specifications for load limits.

Slipping or broken pump drive: repair or replace couplings. Check for alignment.

HYDRAULIC SYSTEM (CONTINUED)

SYMPTOM

SYSTEM OPERATES ERRATICALLY

PROBLEM: REMEDY

Air in the system: check suction side of system for leaks. Repair leaks.

Cold oil: allow ample warm-up time. Use proper weight oil for operating temperature.

Dirty or damaged components: clean or repair as needed.

Restriction in filters or lines: clean and/or replace filter or lines.

Not enough oil in system: fill and check for leaks.

SYSTEM OPERATES SLOWLY

Oil viscosity too high, or "cold oil": Allow oil to warm up before operating.

Low pump drive speed: increase engine speed (check pump owners manual for specifications).

Low oil level: check reservoir and add oil as necessary.

Air in system: check suction side for leaks. Repair leaks.

Badly worn pump, valves, cylinders, etc.: repair or replace faulty component(s) as necessary.

Restrictions in lines or filter: clean and/or replace filter or lines.

Improper adjustments: check orifices, relief valves, etc. Adjust as necessary.

Oil leaks: tighten fittings. Replace seals, gaskets and damaged lines.

SYSTEM OPERATES TOO FAST

Engine running too fast: reduce engine speed.

See Landoll Dealer.

OVER HEATING OF OIL IN SYSTEM

Incorrect, low, dirty oil: use recommended oil. Fill reservoir with clean oil. Replace filter.

Engine running too fast: reduce engine speed.

Excessive component internal leakage: repair or replace component as necessary.

Restriction in filters or lines: clean and/or replace filter or lines.

Insufficient heat radiation: clean dirt and mud from reservoir and components.

Malfunctioning component: repair or replace.

HYDRAULIC SYSTEM (CONTINUED)

SYMPTOM

PROBLEM: REMEDY

FOAMING OF OIL

Incorrect, low, or dirty oil: replace, clean or add oil as needed.

Water in oil: replace oil

Air leaks: check suction line and component seals for suction leaks. Replace defective parts.

NOISY PUMP

Low, incorrect, foamy oil: replace, clean, or add oil as needed.

Suction line plugged: clean out obstruction or replace line. Flush system, replace filter.

Pump damaged: repair or place.

LEAKY PUMP

Damaged or worn shaft seal: Replace seal and/or shaft and check for misalignment.

Loose or broken parts: Tighten or replace.

CYLINDERS MOVE WITH
CONTROL VALVE IN
NEUTRAL POSITION

Leaking cylinder seals or fittings: Replace worn seals or fittings.

Control valve not centering when released: Check linkage for binding and repair.

Valve damaged: Repair or replace.

CONTROL VALVE LEAKS

Seals damaged or worn: Replace.

CYLINDER LEAKS

Seals worn or damaged: Replace.

Rod damaged: Replace.

Barrel damaged: Replace.

CYLINDERS DO NOT FUNCTION,
OR CREEP WITH PTO
DISENGAGED

Leaking fittings or cylinder seals: Tighten loose fittings. Replace worn seals or fittings.

5-6 HYDRAULIC POWER SUPPLY ENGINE PACKAGE

To troubleshoot the engine in the hydraulic engine package, please refer to the owners manual that was provided with the engine package.

5-7 GEARBOX

CHAIN SLIPS ON GEAR

Incorrect chain tension: Tighten chain. Do not torque 7/8-9 threads more than 90 ft-lbs when pulling gearbox forward because no more than 6,000 pounds shall be on each bolt.

Gearbox gear worn out: Replace gearbox gear.

Chain worn out: Replace drive chain.

NOTES:
