

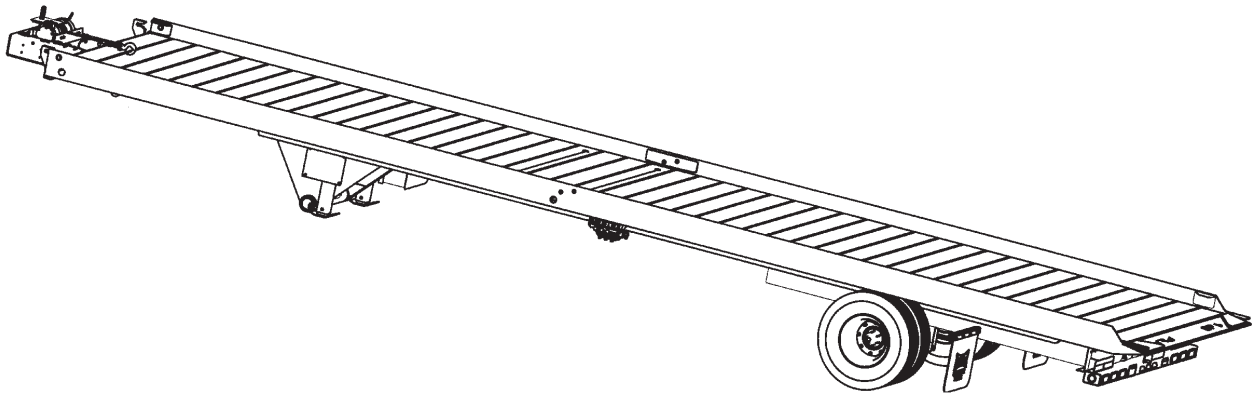

**MODEL 341
SEMITRAILER
OPERATOR'S MANUAL**



**1900 North Street
Marysville, KS 66508
(785)562-5381**

**MODEL 341
SEMITRAILER
OPERATOR'S MANUAL**

PURCHASED FROM: _____ **DATE** ____ / ____ / ____

ADDRESS: _____

PHONE NO.: _____ **SERIAL NO.:** _____

REPORTING SAFETY DEFECTS

If you believe that your vehicle has a defect which could cause a crash or could cause injury or death, you should immediately inform the National Highway Traffic Safety Administration (NHTSA) in addition to notifying Landoll Manufacturing.

If NHTSA receives similar complaints, it may open an investigation, and if it finds that a safety defect exists in a group of vehicles, it may order a recall and remedy campaign. However, NHTSA cannot become involved in individual problems between you, your dealer, or Landoll Manufacturing.

To contact NHTSA, you may either call the Auto Safety Hotline toll-free at 1-800-424-9393 (or 366-0123 in Washington, D.C. area) or write to: NHTSA, U.S. Department of Transportation, Washington, D.C. 20590. You can also obtain other information about motor vehicle safety from the Hotline.

In the event of a defect or problem with your LANDOLL equipment, please notify LANDOLL CORPORATION:

**LANDOLL CORPORATION
SALES AND SERVICE
1900 NORTH STREET
MARYSVILLE, KANSAS 66508**

OR PHONE:

1-800-HAULLOLL

(1-800-428-5655)

FAX NO.: (785)562-3240

FOR REPLACEMENT PARTS:

(785)562-4650

1-800-423-4320

FAX NO.: (785) 562-4654

TABLE OF CONTENTS

SECTION NO.	DESCRIPTION	PAGE NO.
1	INTRODUCTION	1-1
2	STANDARD SPECIFICATIONS.	2-1
3	OPERATING INSTRUCTIONS.	3-1
3-1	PRE-COUPLING OF SEMITRAILER AND TRUCK.	3-2
3-2	COUPLING OF THE TRUCK TO THE SEMITRAILER	3-3
3-3	CONNECTING TRUCK SERVICES TO THE SEMITRAILER.	3-4
3-4	TRUCK AND SEMITRAILER CHECK-OUT	3-5
3-5	TOWING THE SEMITRAILER.	3-6
3-6	PARKING THE SEMITRAILER.	3-7
3-7	UNCOUPLING TRUCK FROM SEMITRAILER.	3-7
3-8	TRAILER TILT LEVER.	3-8
3-9	AXLE CONTROL LEVER.	3-8
3-10	WINCH CONTROLS.	3-8
3-11	GENERAL LOADING PROCEDURE	3-9
3-12	LOADING PROCEDURE FOR 20' CONTAINERS	3-11
3-13	LOADING PROCEDURE FOR 40' CONTAINERS	3-13
3-14	GENERAL UNLOADING PROCEDURE.	3-14
3-15	UNLOADING PROCEDURE FOR 20' AND 40' CONTAINERS	3-16
3-16	AUXILIARY HYDRAULIC POWER ENGINE OPERATION	3-17
3-17	REAR IMPACT GUARD SYSTEM.	3-19
3-18	BLEEDING AND ADJUSTING THE BRAKES	3-20
3-19	INSTALLATION AND ADJUSTMENT OF ELECTRONIC BRAKE CONTROL.	3-21
3-20	RADIO REMOTE CONTROL OPERATION	3-24
3-21	COLD WEATHER OPERATION	3-25
3-22	HOT WEATHER OPERATION	3-25
4	MAINTENANCE AND LUBRICATION	4-1
4-1	MAINTENANCE SCHEDULE	4-1
4-2	MAINTENANCE PROCEDURES.	4-5
4-3	HITCH, FRAME, AND DECK	4-9
4-4	HYDRAULIC SYSTEM	4-9
4-5	ELECTRICAL SYSTEM	4-9
4-6	SUSPENSION MAINTENANCE.	4-10
4-7	ALIGNMENT	4-10
4-8	ELECTRIC/HYDRAULIC BRAKE SYSTEM MAINTENANCE.	4-12
4-9	HUB AND DRUM MAINTENANCE	4-13
4-10	WHEEL BEARING LUBRICATION AND ADJUSTMENT.	4-15
4-11	TIRE MAINTENANCE.	4-16
4-12	HYDRAULIC ENGINE PACKAGE	4-18
5	TROUBLESHOOTING GUIDE.	5-1

SAFETY PRECAUTIONS



THIS IS THE SAFETY ALERT SYMBOL. IT IS USED TO ALERT YOU TO POTENTIAL INJURY HAZARDS. OBEY ALL SAFETY MESSAGES THAT FOLLOW THIS SYMBOL TO AVOID POSSIBLE INJURY OR DEATH.

DANGER

DANGER INDICATES AN IMMINENTLY HAZARDOUS SITUATION WHICH, IF NOT AVOIDED, WILL RESULT IN DEATH OR SERIOUS INJURY.

WARNING

WARNING INDICATES A POTENTIALLY HAZARDOUS SITUATION WHICH, IF NOT AVOIDED, COULD RESULT IN DEATH OR SERIOUS INJURY.

CAUTION

CAUTION INDICATES A POTENTIALLY HAZARDOUS SITUATION WHICH, IF NOT AVOIDED, MAY RESULT IN MINOR OR MODERATE INJURY.

CAUTION

CAUTION USED WITHOUT THE SAFETY ALERT SYMBOL INDICATES A POTENTIALLY HAZARDOUS SITUATION WHICH, IF NOT AVOIDED, MAY RESULT IN PROPERTY DAMAGE.

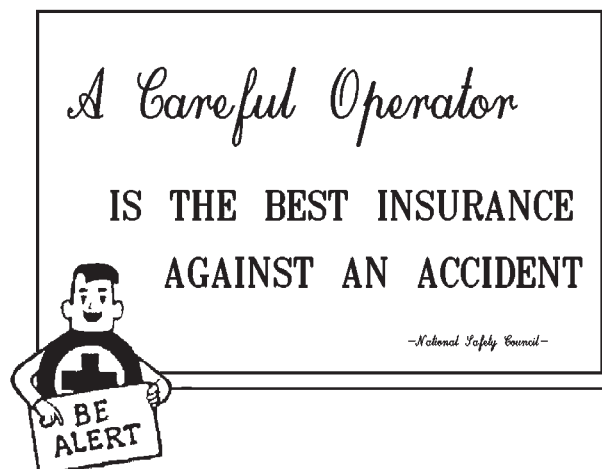

This manual provides operating, servicing, and maintenance instructions, with detailed parts lists for Model 341 semitrailer, manufactured by Landoll Corporation, Marysville, Kansas 66508.

- SECTION 1** gives basic instructions on the use of this manual.

- SECTION 2** gives specifications for the semitrailer, including measurements and component specifications. A Standard Bolt Torque Table is provided to give guidelines for bolt torques to be used when servicing this product.

- SECTION 3** gives instructions for the proper operation of the equipment.

- SECTION 4** gives general maintenance procedures, a maintenance schedule, and a lubrication schedule. Improper maintenance will void your warranty.

IF YOU HAVE ANY QUESTIONS CONTACT:

**LANDOLL CORPORATION
1900 NORTH STREET
MARYSVILLE, KANSAS 66508
or phone:
(785) 562-5381 or
(800) 428-5655
or FAX:
(785) 562-4893**

- SECTION 5** is a troubleshooting guide to aid in diagnosing and solving problems with the semitrailer.

- PARTS LIST** is a separate manual showing the various assemblies, subassemblies, and systems. Refer to that manual when ordering Landoll replacement parts. Order parts from your Landoll dealer.

- WARRANTY** The Warranty Registration form is located with the product documents. Fill it out and mail it within 15 days of purchase. The Warranty is printed inside the front cover.

NOTE: IMPROPER ASSEMBLY, MODIFICATION, OR MAINTENANCE OF YOUR LANDOLL MACHINE CAN VOID YOUR WARRANTY.

- COMMENTS** Address comments or questions regarding this publication to:

**LANDOLL CORPORATION
1900 NORTH STREET
MARYSVILLE, KANSAS 66508
ATTENTION: PUBLISHING -DEPT. 55**

STANDARD SPECIFICATIONS

CAPACITY*:

SINGLE AXLE 15,000 LB. DISTR. - 5,000 LB. in 10 FT.

KING PIN SETTING (FROM FRONT OF ALUMINUM BED): 12"

KING PIN SETTING (FROM WINCH SUPPORT): 42"

UNDERCARRIAGE TRAVEL: 11'-6"

STANDARD LOAD ANGLE: 12°

HYDRAULIC HOOKUP:

QUICK COUPLERS FLAT FACE 3/4" BODY SIZE
MAXIMUM OPERATING PRESSURE 2500 PSI
OPERATING FLOW 17 GPM

ELECTRICAL HOOKUP: 7-WAY CONNECTOR

SPECIFIC BOLT TORQUES

FOR SPRING SUSPENSION:

AXLE CLAMP U-BOLTS 300 FT.-LBS.
TORQUE ARM BOLT 250 FT.-LBS.
TORQUE ARM CLAMP NUTS 60 FT.-LBS.

WHEEL FASTENERS - ALL MODELS:

OUTER SPINDLE NUTS 250-400 FT.-LBS.
PILOT WHEEL NUTS 450-500 FT.-LBS.

* CAPACITY RATINGS ARE FRAME CAPACITIES ONLY. ACTUAL LOAD CAPACITIES MAY BE RESTRICTED BY FACTORS SUCH AS GROSS AXLE WEIGHT RATINGS (GAWR) OR STATE AND FEDERAL REGULATIONS.

**LANDOLL CORPORATION
GENERAL TORQUE SPECIFICATIONS (REV. 4/97)**

THIS CHART PROVIDES TIGHTENING TORQUES FOR GENERAL PURPOSE APPLICATIONS WHEN SPECIAL TORQUES ARE NOT SPECIFIED ON PROCESS OR DRAWING.
 ASSEMBLY TORQUES APPLY TO PLATED NUTS AND CAPSCREWS ASSEMBLED WITHOUT SUPPLEMENTAL LUBRICATION (AS RECEIVED CONDITION). THEY DO NOT APPLY IF SPECIAL GRAPHITE MOLY-DISULFIDE OR OTHER EXTREME PRESSURE LUBRICANTS ARE USED. WHEN FASTENERS ARE DRY (SOLVENT CLEANED), ADD 33% TO AS RECEIVED CONDITION TORQUE.
 BOLT HEAD IDENTIFICATION MARKS INDICATE GRADE AND MAY VARY FROM MANUFACTURER TO MANUFACTURER.
 THICK NUTS MUST BE USED ON GRADE 8 CAPSCREWS.
 USE VALUE IN [] IF USING PREVAILING TORQUE NUTS.
TORQUE IS SPECIFIED IN FOOT POUNDS

UNC Size	SAE Grade 2		SAE Grade 5		SAE Grade 8		UNF Size	SAE Grade 2		SAE Grade 5		SAE Grade 8	
1/4-20	4	[5]	6	[7]	9	[11]	1/4-28	5	[6]	7	[9]	10	[12]
5/16-18	8	[10]	13	[16]	18	[22]	5/16-24	9	[11]	14	[17]	20	[25]
3/8-16	15	[19]	23	[29]	35	[43]	3/8-24	17	[21]	25	[31]	35	[44]
7/16-14	24	[30]	35	[43]	55	[62]	7/16-20	27	[34]	40	[50]	60	[75]
1/2-13	35	[43]	55	[62]	80	[100]	1/2-20	40	[50]	65	[81]	90	[112]
9/16-12	55	[62]	80	[100]	110	[137]	9/16-18	60	[75]	90	[112]	130	[162]
5/8-11	75	[94]	110	[137]	170	[212]	5/8-18	85	[106]	130	[162]	180	[225]
3/4-10	130	[162]	200	[250]	280	[350]	3/4-16	150	[188]	220	[275]	320	[400]
7/8-9	125	[156]	320	[400]	460	[575]	7/8-14	140	[175]	360	[450]	500	[625]
1-8	190	[237]	408	[506]	680	[850]	1-14	210	[263]	540	[675]	760	[950]
1-1/8-7	270	[337]	600	[750]	960	[1200]	1-1/8-12	300	[375]	660	[825]	1080	[1350]
1-1/4-7	380	[475]	840	[1050]	1426	[1782]	1-1/4-12	420	[525]	920	[1150]	1500	[1875]
1-3/8-6	490	[612]	110	[1375]	1780	[2225]	1-3/8-12	560	[700]	1260	[1575]	2010	[2512]
1/1-2-6	650	[812]	1460	[1825]	2360	[2950]	1/1-2-12	730	[912]	1640	[2050]	2660	[3325]

METRIC

COARSE THREAD METRIC CLASS 10.9 FASTENERS AND CLASS 10.0 NUTS AND THROUGH HARDENED FLAT WASHERS, PHOSPHATE COATED, ROCKWELL "C" 38-45.
 USE VALUE IN [] IF USING PREVAILING TORQUE NUTS.

Nominal Thread Diameter mm	Standard Torque		Nominal Thread Diameter mm	Standard Torque					
	Newton-Meters	Foot-Pounds		Newton-Meters	Foot-Pounds				
6	10	[14]	7	[10]	20	385	[450]	290	[335]
7	16	[22]	12	[16]	24	670	[775]	500	[625]
8	23	[32]	17	[24]	27	980	[1105]	730	[825]
10	46	[60]	34	[47]	30	1330	[1470]	990	[1090]
12	80	[101]	60	[75]	33	1790	[1950]	1340	[1450]
14	125	[155]	90	[115]	36	2325	[2515]	1730	[1870]
16	200	[240]	150	[180]	39	3010	[3210]	2240	[2380]
18	275	[330]	205	[245]					

Table 2-1 General Torque Specifications

**LANDOLL CORPORATION
HYDRAULIC FITTING TORQUE SPECIFICATIONS
37° JIC, ORS, & ORB (REV. 10/97)**

THIS CHART PROVIDES TIGHTENING TORQUES FOR HYDRAULIC FITTING APPLICATIONS WHEN SPECIAL TORQUES ARE NOT SPECIFIED ON PROCESS OR DRAWING.
 ASSEMBLY TORQUES APPLY TO PLATED CARBON STEEL AND STAINLESS STEEL FITTINGS ASSEMBLED WITHOUT SUPPLEMENTAL LUBRICATION (AS RECEIVED CONDITION). THEY DO NOT APPLY IF SPECIAL GRAPHITE MOLY-DISULFIDE OR OTHER EXTREME PRESSURE LUBRICANTS ARE USED.
 BRASS FITTINGS AND ADAPTERS - 65% OF THE TORQUE VALUE FOR STEEL. STAINLESS STEEL, ALUMINUM AND MONEL - THREADS ARE TO BE LUBRICATED.
TORQUE IS SPECIFIED IN FOOT POUNDS

PARKER BRAND FITTINGS

Dash Size	37 Degree JIC	O-Ring (ORS)	O-Ring Boss (ORB)
-4	11-13	15-17	13-15
-5	14-16	—	21-23
-6	20-22	34-36	25-29
-8	43-47	58-62	40-44
-10	55-65	100-110	57.5-62.5
-12	80-90	134-146	75-85
-16	115-125	202-218	109-121
-20	160-180	248-272	213-237
-24	185-215	303-327	238-262
-32	250-290	—	310-340

**LANDOLL CORPORATION
HYDRAULIC FITTING TORQUE SPECIFICATIONS
37° JIC, ORS & ORB (REV. 10/97)**

THIS CHART PROVIDES TIGHTENING TORQUES FOR HYDRAULIC FITTING APPLICATIONS WHEN SPECIAL TORQUES ARE NOT SPECIFIED ON PROCESS OR DRAWING.
 ASSEMBLY TORQUES APPLY TO PLATED CARBON STEEL AND STAINLESS STEEL FITTINGS ASSEMBLED WITHOUT SUPPLEMENTAL LUBRICATION (AS RECEIVED CONDITION). THEY DO NOT APPLY IF SPECIAL GRAPHITE MOLY-DISULFIDE OR OTHER EXTREME PRESSURE LUBRICANTS ARE USED.
 BRASS FITTINGS AND ADAPTERS - 65% OF THE TORQUE VALUE FOR STEEL.
TORQUE IS SPECIFIED IN FOOT POUNDS.



AEROQUIP BRAND FITTINGS

Dash Size	37 Degree JIC	O-Ring (ORS)	O-Ring Boss (ORB)
-4	11-12	10-12	14-16
-5	15-16	—	18-20
-6	18-20	18-20	24-26
-8	38-42	32-35	50-60
-10	57-62	46-50	72-80
-12	79-87	65-70	125-135
-14	—	—	160-180
-16	108-113	92-100	200-220
-20	127-133	125-140	210-280
-24	158-167	150-165	270-360
-32	245-258	—	—

Table 2-2 Hydraulic Fitting Torque Specifications

This section supplies information for operation of the trailer. It describes and locates controls and gives general operation procedures. Read all instructions, warnings, cautions and danger notes before attempting to operate the trailer. Operators must have proper training before operating the semitrailer.

A hydraulic pump must be coupled to the trailer hydraulic system, or the optional hydraulic engine package started, before using hydraulic controls.

 WARNING
DO NOT OPERATE THE SEMITRAILER WITH ANY KNOWN FAULT THAT MIGHT ENDANGER THE OCCUPANTS, NEARBY WORKERS, OTHER TRAFFIC, THE LOAD, OR THE EQUIPMENT.
 WARNING
DO NOT OPERATE THE SEMITRAILER UNTIL YOU HAVE READ THE OPERATOR'S MANUAL AND COMPLETELY UNDERSTAND THE PROPER USE AND FUNCTION OF ALL CONTROLS. IMPROPER USE CAN CAUSE PERSONAL INJURY, DAMAGE TO YOUR SEMITRAILER AND CARGO, AND CAUSE TIME-CONSUMING BREAKDOWNS.
 WARNING
INSPECT ALL TRAILER COMPONENTS INCLUDING THE WINCH AND WINCH CABLE FOR ANY CRACKS, BROKEN PARTS OR DEFECTS. REPAIR OR REPLACE BAD PARTS BEFORE OPERATING TRAILER. FAILURE TO DO SO CAN RESULT IN SERIOUS PERSONAL INJURY OR DEATH.

3-0.1 Electric/Hydraulic Brake System

The electric/hydraulic brake system of the trailer is operated from the towing vehicle after coupling.

The electric/hydraulic brake system requires 12 volt power to the red terminal. It should be 10 gauge wire with a 30 amp circuit breaker to protect it. The blue terminal should be controlled by an electronic brake controller that is approved for working with the electric/hydraulic brake unit. Acceptable controllers include the Carlisle "HSC", Tekonsha "Voyager" 9030 and 9035, Envoy 9040, Dexter "Predator", and Draw-tite "Activator II and III". The black terminal is used to charge the break-a-way battery on the trailer.

 CAUTION
1. DISCONNECT TRAILER PLUG FROM THE TOW VEHICLE PRIOR TO TESTING A BREAK-A-WAY SWITCH OR YOU MAY DESTROY THE BRAKE CONTROLLER.
2. IN STOP AND GO TRAFFIC, THE ELECTRIC/HYDRAULIC ACTUATOR CAN GET QUITE WARM TO THE TOUCH. THIS IS NORMAL AND SHOULD NOT BE OF CONCERN. CARE SHOULD BE TAKEN TO LOCATE THE UNIT IN AN AREA WHERE YOUR SKIN WILL NOT COME IN DIRECT CONTACT WITH THE UNIT.
3. THE ELECTRIC/HYDRAULIC ACTUATOR CONTAINS SENSITIVE ELECTRONICS THAT MUST BE PROTECTED. DRILLING ADDITIONAL HOLES IN THE ACTUATOR HOUSING OR WELDING ANYWHERE ON THE UNIT WILL DAMAGE THE UNIT MAKING IT INOPERABLE AND WILL VOID THE MANUFACTURER'S WARRANTY. ALWAYS MAKE SURE TO DISCONNECT THE ACTUATOR FROM THE TRAILER ELECTRICAL SYSTEM BEFORE DOING ANY WELDING REPAIR OR MODIFICATIONS TO THE TRAILER STRUCTURE.

⚠ WARNING

THE ELECTRIC/HYDRAULIC ACTUATOR AND TRAILER BRAKES ARE INTENDED ONLY TO SUPPLEMENT THE SERVICE BRAKE SYSTEM ON THE TOWING VEHICLE. THE ACTUATOR AND TRAILER BRAKES ARE NOT DESIGNED TO FUNCTION AS A PARK BRAKE. AT NO TIME SHOULD THE TOWED VEHICLE BRAKE SYSTEM BE USED AS THE PRIMARY SOURCE OF BRAKING FOR THE TOWING VEHICLE.

⚠ WARNING

WHEN STOPPED FOR EXTENDED PERIODS (MORE THAN TWO MINUTES), APPLY THE PARK BRAKE ON THE TOWING VEHICLE AND RELEASE THE SERVICE BRAKE PEDAL SO THAT THE ELECTRIC/HYDRAULIC ACTUATOR DOES NOT RUN CONTINUOUSLY. FAILURE TO FOLLOW THIS GUIDELINE WILL CAUSE THE UNIT TO OVERHEAT AND WILL DAMAGE THE UNIT.

⚠ WARNING

DO NOT ATTEMPT TO TOW THE TOWED VEHICLE UNLESS THE EMERGENCY BREAK-A-WAY BATTERY IS FULLY CHARGED.

⚠ WARNING

ALTHOUGH THE ELECTRIC/HYDRAULIC ACTUATOR IS WEATHER TIGHT, IT IS NOT DESIGNED TO WITHSTAND THE DIRECT SPRAY FROM A POWER/CAR WASH. CARE SHOULD BE TAKEN TO PROTECT THE UNIT FROM DIRECT SPRAY WHEN WASHING THE TRAILER.

⚠ WARNING

DO NOT LEAVE THE BREAK-A-WAY SWITCH PULLED FOR MORE THAN TWO MINUTES. THE ELECTRIC/HYDRAULIC UNIT WILL OVERHEAT IF RAN CONTINUOUSLY FOR MORE THAN TWO MINUTES.

3-1 PRE-COUPLING OF SEMITRAILER AND TRUCK

3-1.1 Slowly back the truck up to the front end of the semitrailer so the kingpin of the semitrailer is centered between the truck fifth wheel jaws. Stop the truck several inches ahead of the semitrailer. Set truck parking brake.

3-1.2 The king pin plate should be the same height as the latch area of the fifth wheel plate of the truck. If necessary, connect the truck hydraulic lines or start the trailer hydraulic power engine. Use the **TRAILER TILT** lever (**See Figure 3-2**) to raise or lower the kingpin plate sufficiently to allow proper coupling.

3-1.3 Before coupling any lines to trailer, test the emergency brakes of trailer by pulling pin of emergency break-a-way switch. The electric/hydraulic brake unit should run and apply brakes. Do not let the brake unit run more than two minutes or the brake unit will get hot and damage the unit.

3-1.4 If emergency brakes do not come on, repair problem before going any further. If they work, then place pin back in break-a-way switch.

3-2 COUPLING OF THE TRUCK TO THE SEMITRAILER

DANGER

KEEP ALL PERSONNEL CLEAR OF FRONT, REAR, AND SIDES OF TRUCK AND SEMITRAILER DURING COUPLING, COMPONENT OPERATIONS, AND UNCOUPLING. FAILURE TO STAY CLEAR CAN RESULT IN SERIOUS PERSONAL INJURY OR DEATH.

3-2.1 Verify the semitrailer wheels are chocked.

3-2.2 Make sure the truck's fifth wheel coupler is open.

3-2.3 Slowly back the truck so the fifth wheel contacts the kingpin plate. Continue backing until the fifth wheel coupler locks onto the kingpin.

3-2.4 Try to pull the truck forward a few inches to verify the vehicle coupling is secure. If the truck disconnects from the semitrailer: locate the source of the coupling failure; repair before continuing; and repeat **Steps 3-2.3 and 3-2.4.**

CAUTION

PUSHING SEMITRAILER BACKWARDS CAN DAMAGE LANDING GEAR.

3-2.5 Check that the truck couples securely to the semitrailer before setting truck parking brakes.

IMPORTANT

KEEP TRUCK PARKING BRAKES ENGAGED FOR REMAINDER OF COUPLING, CHECK-OUT, AND PARKING.

3-3 CONNECTING TRUCK SERVICES TO THE SEMITRAILER

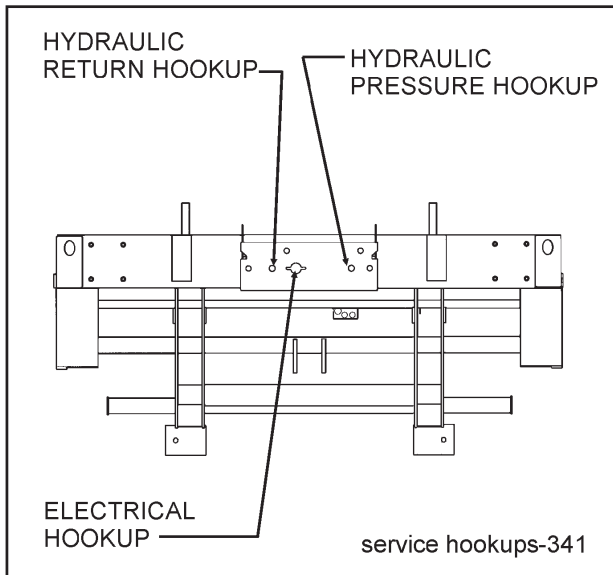

Figure 3-1 Service Hookups (Front View)

3-3.1 Connect the truck 7-way electrical plug to the electrical receptacle on the front of the semitrailer (See Figure 3-1).

IMPORTANT

THE KEY ON THE PLUG AND THE KEYWAY IN THE SOCKET MUST BE PROPERLY ALIGNED BEFORE INSERTING THE PLUG INTO THE SEMITRAILER SOCKET.

3-3.2 If you have not already done so, connect the truck hydraulic lines to the semitrailer, unless your semitrailer is equipped with the auxiliary hydraulic power engine package.

IMPORTANT

SOME OIL MAY NEED TO BE REMOVED FROM THE TRUCK RESERVOIR TO ALLOW ROOM FOR 7 GALLONS OF ADDITIONAL OIL DISPLACED FROM THE SEMITRAILER HYDRAULIC SYSTEM.

3-3.3 Connect the break-a-way switch cable to a part of the truck so, if the trailer becomes disconnected from the truck, the cable will pull the pin of the break-a-way switch and stop the trailer.

3-4 TRUCK AND SEMITRAILER CHECK-OUT

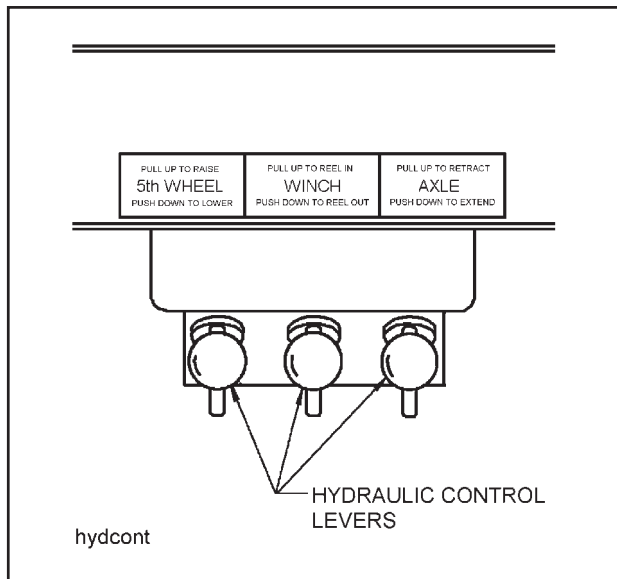

Figure 3-2 Hydraulic Control Levers

3-4.1 While hydraulic power is operating, raise the front end of the semitrailer with the **TRAILER TILT** lever (See **Figure 3-2**) until weight is off the landing gear. Raise landing gear. Secure each leg with a park stand retaining pin in fully retracted position before transporting.

! WARNING

LANDING GEAR LEGS MUST BE FULLY RETRACTED AND SECURED WITH PINS BEFORE OPERATING OR MOVING SEMITRAILER.

- 3-4.2** Lower the front end with the **TRAILER TILT** lever until the semitrailer is fully lowered. Hold lever in the down position until hydraulic system works against the bottomed out hydraulic tilt cylinders.
- 3-4.3** Verify that the traveling undercarriage is completely slid back to transport position. Shut off hydraulic power.
- 3-4.4** Check the operation of all lights and signals on the semitrailer for proper response to switch positions (stop, right turn, left turn and clearance).
- 3-4.5** Check that tire inflation matches the pressure listed on the tire.
- 3-4.6** Check truck/semitrailer combination for leaks. If leakage is found, repair the defect before transporting.
- 3-4.7** Check that the oil in each hub is at the proper level and free from contamination. If hubs contain water, dirt, or other foreign matter, clean them before transporting.
- 3-4.8** Set truck parking brake and carefully remove all wheel chocks. Depress truck brake pedal. The brake unit should make a humming noise. With the brake pedal depressed, slide the manual slide on the electronic brake controller over to apply brakes. The brake unit should apply the trailer brakes. The brake unit humming noise will change pitch as the brake unit builds up pressure in the hydraulic brakes.

3-5 TOWING THE SEMITRAILER

- 3-5.1** Driving the truck with the semitrailer coupled behind requires constant attention to the overall length. Turning, passing, accelerating, braking, stopping, and back-up require special considerations. When executing steep grades or turning tight curves, the semitrailer must not be allowed to push the truck, or jack knifing may result. Application of the semitrailer brakes to keep the semitrailer in tow will help prevent this situation. To assure control, brake before descending a hill or attempting a curve.
- 3-5.2** Make a moving test of the semitrailer brakes at low and medium speeds **before** traveling at highway speed. The gain setting on the in-cab electronic controller may have to be adjusted depending on how much load is on the trailer. If braking is too severe, adjust the gain setting down to decrease pressure. If braking is inadequate, increase the gain setting to increase pressure. The electronic controller in normal operation does not send a signal to apply brakes if the trailer is not moving because it is inertia activated. The electronic controller does have a manual slide knob that will override the normal operation though that can be used to apply the brakes.
- 3-5.3** When stopping trailer for more than two minutes, use truck parking brakes or chock tires of trailer.

CAUTION

DO NOT APPLY TRAILER BRAKES FOR MORE THAN TWO MINUTES OR IT WILL GET THE BRAKE UNIT HOT AND DAMAGE THE BRAKE UNIT.

CAUTION

WHEN OPERATING TRAILER, DO NOT BACK OVER CURB. THIS WILL CAUSE SEVERE DAMAGE TO UNDERCARRIAGE AND UNDERCARRIAGE CYLINDER.

- 3-5.4** The semitrailer wheels track to the inside of the truck during turns. Thus, turning corners requires a wide swing to prevent "curb hopping", and to allow the semitrailer wheels to clear any obstacle on the inside of the corner.
- 3-5.5** To stop, use a gradual and smooth application of brakes. If grabbing occurs, apply less pressure. Grabbing brakes are not efficient.

DANGER

ALWAYS CHECK BEHIND AND UNDER THE TRUCK AND SEMITRAILER FOR PERSONS OR OBJECTS BEFORE MOVING. FAILURE TO CHECK CAN LEAD TO SERIOUS PERSONAL INJURY, DEATH, OR DAMAGE TO PROPERTY.

- 3-5.6** Backing should be done with care. Tail overhang, semitrailer length, and allowable space must be taken into consideration.

3-6 PARKING THE SEMITRAILER

- 3-6.1 Position truck/trailer rig on a level, solid surface.
- 3-6.2 Set the **TRUCK PARKING BRAKE** and check for proper brake holding.
- 3-6.3 Chock wheels.

WHEN LEAVING THE SEMITRAILER UNATTENDED, POSITION ALL HYDRAULIC CONTROLS TO THE NEUTRAL OR "OFF" POSITION AND SHUT OFF THE HYDRAULIC ENGINE POWER SUPPLY, OR DISCONNECT THE TRUCK HYDRAULIC HOOK-UP.

WARNING

3-7 UNCOUPLING TRUCK FROM SEMITRAILER

- 3-7.1 Park the semitrailer according to instructions in **Section 3-6**.
- 3-7.2 Remove retaining pin and lower landing gear to the ground. Hydraulically raise the front end of the semitrailer until the next hole in the landing gear is available. Insert pin through both inner and outer legs of the landing gear. Hydraulically lower semitrailer onto the legs.

WARNING

SECURE EACH LEG WITH PIN BEFORE LEAVING SEMITRAILER UNATTENDED.

- 3-7.3 Pull the truck fifth wheel plate latch release.
- 3-7.4 Disconnect the 7-way cable and hydraulic lines from the semitrailer and store with the truck.
- 3-7.5 Attempt to pull the truck forward. If the truck uncouples, verify that all service lines are disconnected and semitrailer wheels are chocked. If truck does not disconnect, repeat **Sections 3-7.3 and 3-7.5**.
- 3-7.6 Pull the truck away from the semitrailer.

3-8 TRAILER TILT LEVER

The **TRAILER TILT** lever is located on the driver's side of the semitrailer under the outer frame beam. (See **Figure 3-2**) It has three positions:

UP In this position, the front end of the semitrailer rises to the load position.

CENTER This is the neutral position. The semitrailer stays in its current position.

DOWN In this position, the front end of the semitrailer lowers to the transport position.

3-9 AXLE CONTROL LEVER

The **AXLE CONTROL** lever (See **Figure 3-2**) is the control on the rear with three positions:

UP

In this position, the undercarriage slides forward for loading.

CENTER This is the neutral position.

DOWN In this position, the undercarriage slides to the rear. The undercarriage must be in the rear-most position for transport.

3-10 WINCH CONTROLS

DANGER

1. THE WINCH IS NOT DESIGNED OR INTENDED TO BE USED FOR LIFTING OR MOVING PEOPLE. USING IT THIS WAY CAN CAUSE SERIOUS INJURY OR DEATH.

2. MAKE CERTAIN THE WINCH CABLE SPOOL CLUTCH IS SET TO ENGAGE AND CLUTCH IS FULLY ENGAGE BEFORE LOAD TENSION IS APPLIED TO WINCH CABLE. NEVER ATTEMPT TO DISENGAGE THE WINCH CABLE SPOOL WHEN THE CABLE IS UNDER TENSION. LOSS OF LOAD CONTROL, PROPERTY DAMAGE, INJURY OR DEATH CAN RESULT.

3. FAILURE TO LEAVE AT LEAST FIVE WINCH CABLE WRAPS ON THE WINCH CABLE SPOOL COULD ALLOW THE CABLE TO COME OFF THE SPOOL, RESULTING IN SERIOUS PERSONAL INJURY OR DEATH.

3-10.1 The **12,000# WINCH CLUTCH HANDLE** (See **Figure 3-3**) is on the curbside of the winch assembly. The 12,000 pound winch clutch handle has two positions that engage or disengage the winch spool:

DISENGAGE In this position, the winch is disengaged. This allows the spool to "free-wheel". **This is only used when there is no load on the winch cable.** This feature allows the cable to be pulled out fairly fast and does not require operating the hydraulic system.

ENGAGE In this position, the winch is engaged. Cable may be "power" spooled on or off the winch spool. The winch is now controlled by the Winch Hydraulic Lever.

3-10.2 The **HYDRAULIC WINCH CONTROL LEVER** is the center lever (See Figure 3-2). It has three positions:

UP In this position, the winch reels the winch cable in.

CENTER This is the neutral position. This position has some holding power, but cannot be relied upon to hold a load during transport.

DOWN In this position, the winch reels the winch cable out.

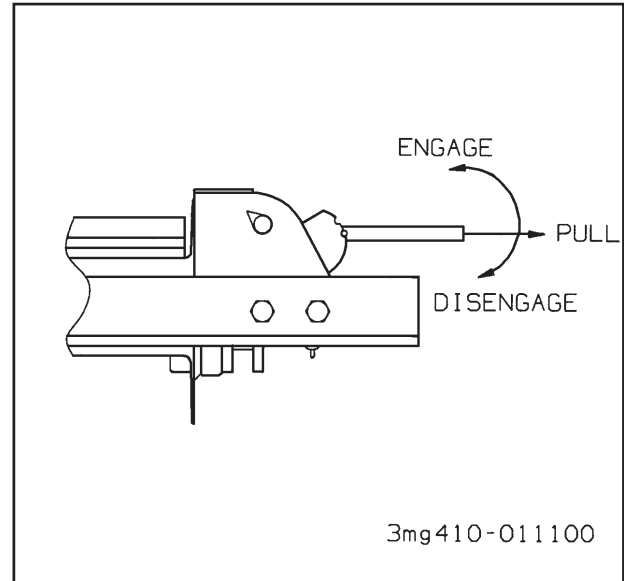

Figure 3-3 Winch Clutch Handle

3-11 GENERAL LOADING PROCEDURE

3-11.1 Practice all standard industrial safety standards (See Figure 3-7). Do not load any payload that will overload any component of the semitrailer or cause any unsafe condition.

3-11.2 Proper operation requires that the undercarriage be pulled fully forward to create lowest low load angle.

3-11.3 Park the truck/semitrailer in a straight line on level even surface. Set the truck parking brakes (See Figure 3-7).

3-11.4 Start operation of hydraulic power system. If the hydraulic engine package is installed, start and warm up engine following engine operating instructions in Section 3-16. (Read engine operator's manual.)

3-11.5 Alternate between moving the undercarriage forward and tilting the front of the bed up until the undercarriage is fully forward and the approach plate is on the ground. The weight of the semitrailer bed should rest partly on approach plate and partly on undercarriage. The object is to have the approach plate resting on the ground whenever the center of gravity of the semitrailer and load is behind the rear axle of semitrailer. In loading position, the approach plate should be resting on the ground and the undercarriage fully forward.

⚠ CAUTION

DO NOT ALLOW THE SEMITRAILER AXLE TO LEAVE THE GROUND. THIS CAN RESULT IN DAMAGE TO THE SEMITRAILER.

⚠ WARNING

IN LOADING OR UNLOADING POSITION, THE APPROACH PLATE SHOULD BE RESTING ON THE GROUND AND THE UNDERCARRIAGE FULLY FORWARD.

⚠ WARNING

ALWAYS USE LOW LOAD ANGLE TO LOAD AND UNLOAD POWERED PRODUCTS.

IMPORTANT

SECTION 3-12 DESCRIBES SPECIFIC PROCEDURES FOR LOADING 20' CONTAINERS. SECTION 3-13 DESCRIBES SPECIFIC PROCEDURES FOR LOADING 40' CONTAINERS.

3-11.6 Winch or drive the load onto the semitrailer. Insure that the load is steering straight up onto the semitrailer and does not maneuver off the side of the semitrailer. Continue until load center of gravity is just ahead of the axles. The load should never place more weight on the kingpin than on the rear axles during loading and unloading.

<p>⚠ CAUTION</p>
<p>MAXIMUM CONCENTRATED LOAD IS 5,000 LBS. IN A 10 FT. AREA FOR A SINGLE AXLE SEMITRAILER.</p>
<p>⚠ WARNING</p>
<p>1. THE SEMITRAILER MUST BE COUPLED TO A TRUCK AND THE LANDING GEAR RAISED OFF THE GROUND BEFORE OPERATING.</p> <p>2. DO NOT EXCEED THE GROSS AXLE WEIGHT RATINGS FOR ANY AXLE ON YOUR VEHICLE. THE COMBINED WEIGHT OF THE SEMITRAILER AND CARGO MUST NOT EXCEED THE GROSS VEHICLE WEIGHT RATING (GVWR) OF THE TRAILER.</p>
<p>⚠ WARNING</p>
<p>THE CENTER OF GRAVITY OF THE LOAD MUST BE IN FRONT OF THE CENTER OF THE UNDERCARRIAGE WHENEVER THE APPROACH PLATE IS NOT SUPPORTED BY THE GROUND. FAILURE TO DO THIS CAN CAUSE THE SEMITRAILER TO TILT BACK RESULTING IN INJURY OR DEATH.</p>

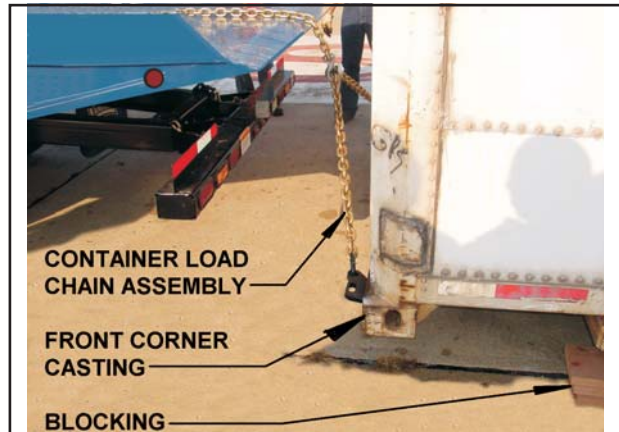

Figure 3-4 Front Corner Castings

- 3-11.7** If the load center of gravity is not ahead of the rear axle, alternate between tilting the front of the bed up and moving the undercarriage to the rear, until the center of gravity of the semitrailer load is in front of the rear axle. Keep part of the load on the wheels and part on the approach plate. Never move the undercarriage so far to the rear that the approach plate is lifted off the ground during this procedure.
- 3-11.8** When the center of gravity of the semitrailer and load is in front of the rear axle, fully lower the tilt angle.
- 3-11.9** After bed tilt angle is fully lowered, move the undercarriage to the rear until it is in transport position. The undercarriage transport position shall be when the undercarriage bumper is no more than 12" in front of the end of the trailer or the end of the load which ever is the farthest back. This is for underride protection. Hold **TRAILER TILT** lever in the down position until hydraulic system works against the bottomed out Hydraulic Tilt Cylinders.
- 3-11.10** If necessary, unsecure the load, move load slightly forward or rearward on the load bed to get correct weight distribution on kingpin and the semitrailer axles, and resecure the load with the tiedowns and winch cable.
- 3-11.11** Shut down the auxiliary hydraulic power engine following operating instructions in **Section 3-16**.
- 3-11.12** Recheck that the load is properly secured. Assure maintenance schedule is up-to-date and semitrailer is ready to be pulled.

3-12 LOADING PROCEDURE FOR 20' CONTAINERS

- 3-12.1** Read general loading procedures first to become familiar with how to operate the trailer (**See Section 3-11**).
- 3-12.2** Check the container to be loaded to see if the container front corner castings are an inch or so off the ground. If they are not, the container will have to be lifted first and blocks placed a few inches behind front of container to keep container an inch or so off the ground (**See Figure 3-4**).
- The trailer can be used to lift empty containers. The trailer should be straight in front of container and as close to container as possible without hitting container.
 - Operating trailer using the same methods described **Section 3-11**, move the undercarriage forward a couple feet and tilt the front of trailer up fully.
 - Connect the container chain harnesses provided with trailer to the container corner castings (**See Figure 3-5**).
 - Connect the container chain harness to the winch cable hook.
- Operate the winch to tighten the chain. **See Section 3-10** for winch operating instructions.
 - Tilt the trailer down until the front of container is lifted enough to block up an inch or so.
 - Install provided container stops in container stop hole on the trailer where front of container is going to be pulled up to (**See Figure 3-6**). The lower hole is used to stop container. The upper hole is used to hold container to trailer.
- 3-12.3** Pull undercarriage forward and tilt the rear of trailer to within a half inch off the ground.
- Move trailer back under front of container a few inches.
 - Tighten chain attached to container by operating winch.
 - The truck and trailer can be pulled under container by releasing both truck and trailer brakes, but make sure either the container or trailer approach plate is always on the ground so the truck and trailer do not roll away freely. An operator needs to be in the truck to apply the brakes just in case the truck and trailer do start to roll away freely.
- 3-12.4** Operate winch until container is up against container stops. When container is against stops, the other container pin is to install in upper hole in trailer that lines up with slot in front bottom container corner castings to hold container in place.

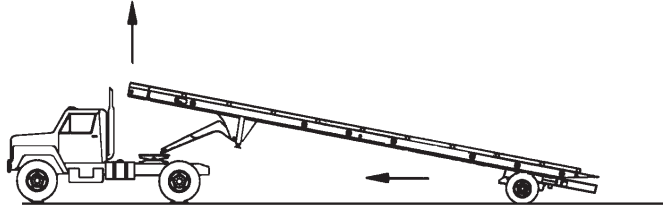

Figure 3-5 Chain Connections



Figure 3-6 Container Stops

LOADING



 **WARNING** : ALWAYS USE LOW LOAD ANGLE TO LOAD AND UNLOAD POWERED PRODUCTS.

 **WARNING** : CENTER OF GRAVITY OF LOAD MUST REMAIN AHEAD OF SUSPENSION CENTER WHEN APPROACH PLATE IS NOT SUPPORTED BY GROUND.

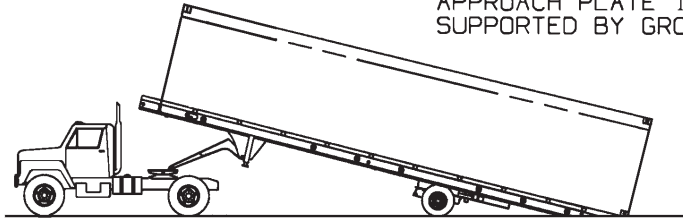

 **CAUTION** : DO NOT ALLOW BACK AXLE TO LEAVE THE GROUND.

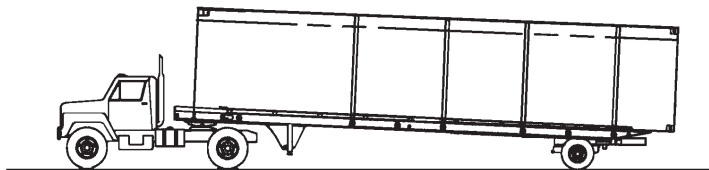
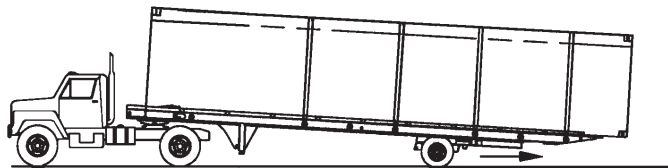

UNLOADING

load-unload

Figure 3-7 Steps for Loading and Unloading

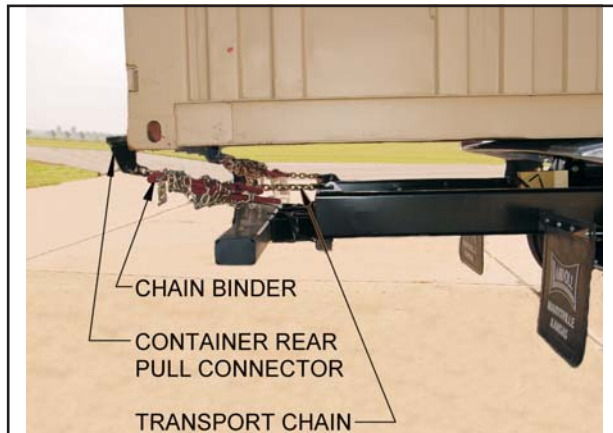

Figure 3-8 Chain Binder Use

3-12.5 Bring the trailer back to road position using same procedure as **Section 3-11.7 thru 3-11.9**.

3-12.6 Connect chains on undercarriage to rear container corner castings.

3-12.7 Use chain binders to tighten the chain from undercarriage to container (**See Figure 3-8**).

3-13 LOADING PROCEDURE FOR 40' CONTAINERS

3-13.1 Read general loading procedures first to become familiar with how to operate the trailer (**See Section 3-11**).

3-13.2 Check the container to be loaded to see if the container front corner castings are an inch or so off the ground. If they are not, the container will have to be lifted first and blocks placed a few inches behind front of container to keep container an inch or so off the ground (**See Figure 3-4**).

- a. The trailer can be used to lift empty containers. The trailer should be straight in front of container and as close to container as possible without hitting container.
- b. Operating trailer using the same methods described earlier in this section, move the undercarriage forward a couple feet and tilt the front of trailer up fully.
- c. Connect the container chain harnesses provided with trailer to the container corner castings (**See Figure 3-5**).
- d. Connect the container chain harness to the winch cable hook.

e. Operate the winch to tighten the chain. **See Section 3-10** for winch operating instructions.

f. Tilt the trailer down until the front of container is lifted enough to block up an inch or so.

3-13.3 Pull undercarriage forward and tilt the rear of trailer to within a half inch off the ground.

- a. Move trailer back under front of container a few inches.
- b. Tighten chain attached to container by operating winch.
- c. The truck and trailer can be pulled under container by releasing both truck and trailer brakes, but make sure either the container or trailer approach plate is always on the ground so the truck and trailer do not roll away freely. An operator needs to be in the truck to apply the brakes just in case the truck and trailer do start to roll away freely

3-13.4 Winch the 40' container up to within 4' of front of trailer.

3-13.5 Bring the trailer back to road position using same procedure as **Section 3-11.7 thru 3-11.9**.

3-13.6 Connect chains on undercarriage to rear container corner castings.

3-13.7 Disconnect winch cable from container chain harness and get cable out of way of container coming forward.

3-13.8 Pull undercarriage forward which will pull container onto trailer farther. Pull container on until chain harness goes into hold-downs at front of trailer. Pin container harness to hold-downs with pin provided (See **Figure 3-9**).

3-13.9 Slide undercarriage back until bumper is within a foot of rear of container (See **Figure 3-10**).

3-13.10 Use chain binders to tighten the chain from undercarriage to container (See **Figure 3-8**).

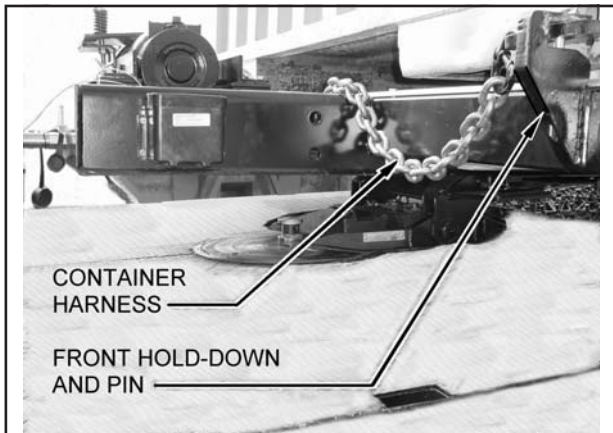

Figure 3-9 Location of Front Hold-down



Figure 3-10 Distance Between U/C and Container

3-14 GENERAL UNLOADING PROCEDURE

⚠ WARNING

NEVER TILT THE TRAILER WITHOUT THE LOAD PROPERLY RESTRAINED. FAILURE TO DO SO MAY RESULT IN THE LOAD MOVING RESULTING IN SERIOUS PERSONAL INJURY, DEATH, OR DAMAGE TO PROPERTY IN IT'S PATH.

⚠ WARNING

DO NOT PULL THE REAR AXLE OF TRAILER FARTHER FORWARD THAN THE CENTER OF GRAVITY OF THE PAYLOAD WHEN REAR APPROACH PLATE IS OFF THE GROUND. FAILURE TO OPERATE CORRECTLY CAN ALLOW FRONT OF TRAILER TO GO UP AND PULL TOWING TRUCK OFF THE GROUND RESULTING IN SERIOUS PERSONAL INJURY, DEATH, OR DAMAGE TO PROPERTY IN ITS PATH.

- 3-14.1 Practice all standard industrial safety standards (**See Figure 3-7**).
- 3-14.2 Park towing vehicle and trailer on relatively level ground.
- 3-14.3 Set truck parking brakes.
- 3-14.4 Engage the P.T.O. or start the hydraulic power engine.
- 3-14.5 Alternate between raising the trailer and pulling the axles forward until the approach plate touches the ground. Never pull the axles forward so far that center of gravity of the load and trailer are behind the rear axle of the trailer unless the approach plate is on the ground. Always use low load angle to unload powered products. To achieve low load angle, the undercarriage has to be all the way forward. The object is to keep a part of the weight on the approach plate, and part of the weight on the wheels while lowering the tilt angle. The maximum load angle is only intended, if required, for unloading non-powered products and to transfer load to truck. Transfer load to truck by raising deck and moving axles toward rear until load is forward of the rear axle, thus transferring load to truck.
- 3-14.6 If load is non-powered, insure that the winch cable is firmly attached to the load and tension is on the cable. Tilt trailer according to **Section 3-14.5**. With cable firmly attached to load, remove other load securing devices. Use the winch to assist the load down to the end of the approach plate. With end of load resting on the ground, block load from rolling or sliding, if necessary. Disconnect the chain connectors and move the trailer from under the load, allowing the load to move off trailer to the ground.

 WARNING
<p>WHEN REMOVING LOAD, INSURE THAT THE LOAD IS STEERING STRAIGHT SO IT DOES NOT MANEUVER OFF THE SIDE OF THE TRAILER. FAILURE TO DO SO COULD RESULT IN DAMAGE TO EQUIPMENT, INJURY, OR DEATH.</p>

- 3-14.7 If load is powered, tilt trailer according to **Section 3-14.5**. Make sure the trailer tilt is at the lowest load angle. Remove safety secure devices. Take tension off winch cable and remove cable connectors. Power load off the trailer.
- 3-14.8 Before returning the trailer to transport position, insure that there is sufficient distance between the load and the rear of the trailer so that the trailer does not hit the load when being folded back to transport position.

 CAUTION
<p>BEFORE RETURNING THE TRAILER TO TRANSPORT POSITION, INSURE THAT THERE IS SUFFICIENT DISTANCE BETWEEN THE LOAD AND THE REAR OF THE TRAILER. FAILURE TO DO SO MAY RESULT IN DAMAGE TO THE TRAILER AND/OR LOAD.</p>

- 3-14.9 Tilt the bed down and move undercarriage rearward to transport position. Transport position is when undercarriage bumper is within 12" of rear of trailer. Hold **TRAILER TILT** lever in the down position until hydraulic system works against the bottomed out Hydraulic Tilt Cylinders.
- 3-14.10 Disengage the P.T.O. system of truck or shut off the hydraulic power engine.

3-15 UNLOADING PROCEDURE FOR 20' AND 40' CONTAINERS

3-15.1 Read general unloading procedures first to become familiar with how to operate the trailer. The unloading of containers is similar to unloading other loads. The procedures for getting the trailer ready to unload are the same (**See Section 3-14**).

3-15.2 For unloading a 20' or 40' container, remove all tiedown restraints such as chain binders, rear container hold-downs, and front hold-down pins from the container before tilting the trailer (**See Figures 3-8 and 3-9**).

WARNING

WHEN REMOVING LOAD, INSURE THAT THE LOAD IS STEERING STRAIGHT SO IT DOES NOT MANEUVER OFF THE SIDE OF THE TRAILER. FAILURE TO DO SO COULD RESULT IN DAMAGE TO EQUIPMENT, INJURY, OR DEATH.

WARNING

MAKE SURE NOTHING IS BEHIND THE TRAILER FOR SEVERAL FEET IN CASE THE CONTAINER STARTS SLIDING BACK WHEN THE TRAILER IS TILTED. SEVERE DAMAGE OR INJURY COULD OCCUR TO THE CONTAINER OR OTHER OBSTRUCTION IN THE PATH OF THE SLIDING CONTAINER.

- a. Tilt the trailer at a low load angle and pull undercarriage forward until the approach plate is on the ground.
- b. Take tension off winch cable and disconnect winch cable.
- c. The truck and trailer can now be pulled forward out from underneath the container.

3-15.3 Use the same procedure for returning the trailer back to transport as described in **Sections 3-14.8 and 3-14.9**.

3-16 AUXILIARY HYDRAULIC POWER ENGINE OPERATION

3-16.1 The Hydraulic Power Supply Engine is used to power the hydraulic functions, should the truck not be equipped with hydraulic hookups.

IMPORTANT

1. CHECK THE FOLLOWING FLUID LEVELS BEFORE STARTING THE ENGINE PACKAGE: ENGINE OIL, FUEL SUPPLY, HYDRAULIC OIL. (CHECK OIL LEVEL WHILE SEMITRAILER IS NOT TILTED AS TILTING WILL CHANGE THE OIL LEVEL IN THE TANK.)

2. IF THE ENGINE DOES NOT CRANK, CHECK THE FOLLOWING ON THE BATTERY: CHARGE, FLUID, TERMINALS, AND CABLES. TAKE CORRECTIVE ACTIONS AS NEEDED.

CAUTION

IF THE HYDRAULIC FLUID LEVEL IS LOW DURING OPERATION, THE SEMITRAILER MAY NOT OPERATE CORRECTLY, RESULTING IN DAMAGE TO THE SEMITRAILER.

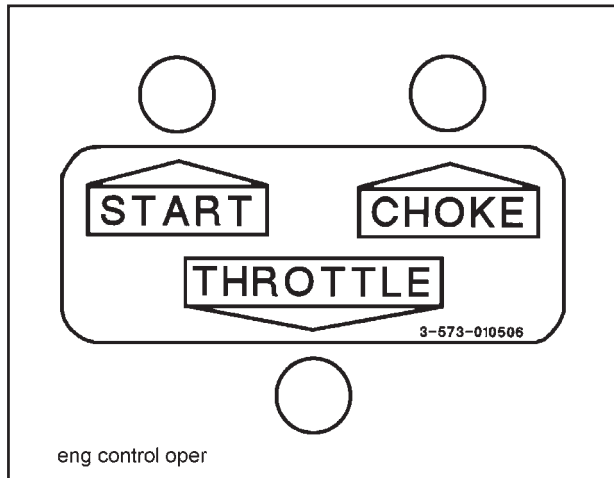

Figure 3-11 Engine Control Panel

3-16.2 The Engine Ignition Switch, Choke and Throttle are on the Engine Control Panel mounted on the drivers side by the hydraulic controls. (See Figure 3-11).

3-16.3 The **HYDRAULIC POWER SUPPLY ENGINE THROTTLE** controls the speed at which the engine operates (See Figure 3-11). It is a variable position control:

HIGH In this position, the engine throttle is fully open, letting it run at full speed.

LOW In this position, the engine throttle is closed, letting the engine run at a slow idle.

3-16.4 To start pull the choke completely out and set the throttle to the LOW position.

3-16.5 Turn the ignition key to the START position. The engine should crank and then start.

CAUTION

DO NOT CRANK ENGINE FOR MORE THAN 30 SECONDS. IF ENGINE DOES NOT START CONSULT THE OWNER'S MANUAL SUPPLIED WITH THE ENGINE.

3-16.6 When the engine starts, release the key. Gradually push the choke lever in until the engine runs smoothly.

3-16.7 Black smoke from the exhaust and a rough running engine usually indicate over-choking.

3-16.8 To adjust the speed, turn the throttle control in or out, as needed, until the engine runs smoothly at a speed capable of withstanding use of the hydraulic controls. The hydraulic controls should now be functional.

3-16.9 Before shutting it off, allow the engine to cool down by running at a slow idle for one to two minutes. Then turn the ignition switch to the off position.

3-16.10 Once the engine is cool, turn or push the throttle and choke control completely in and turn the key to the OFF position.

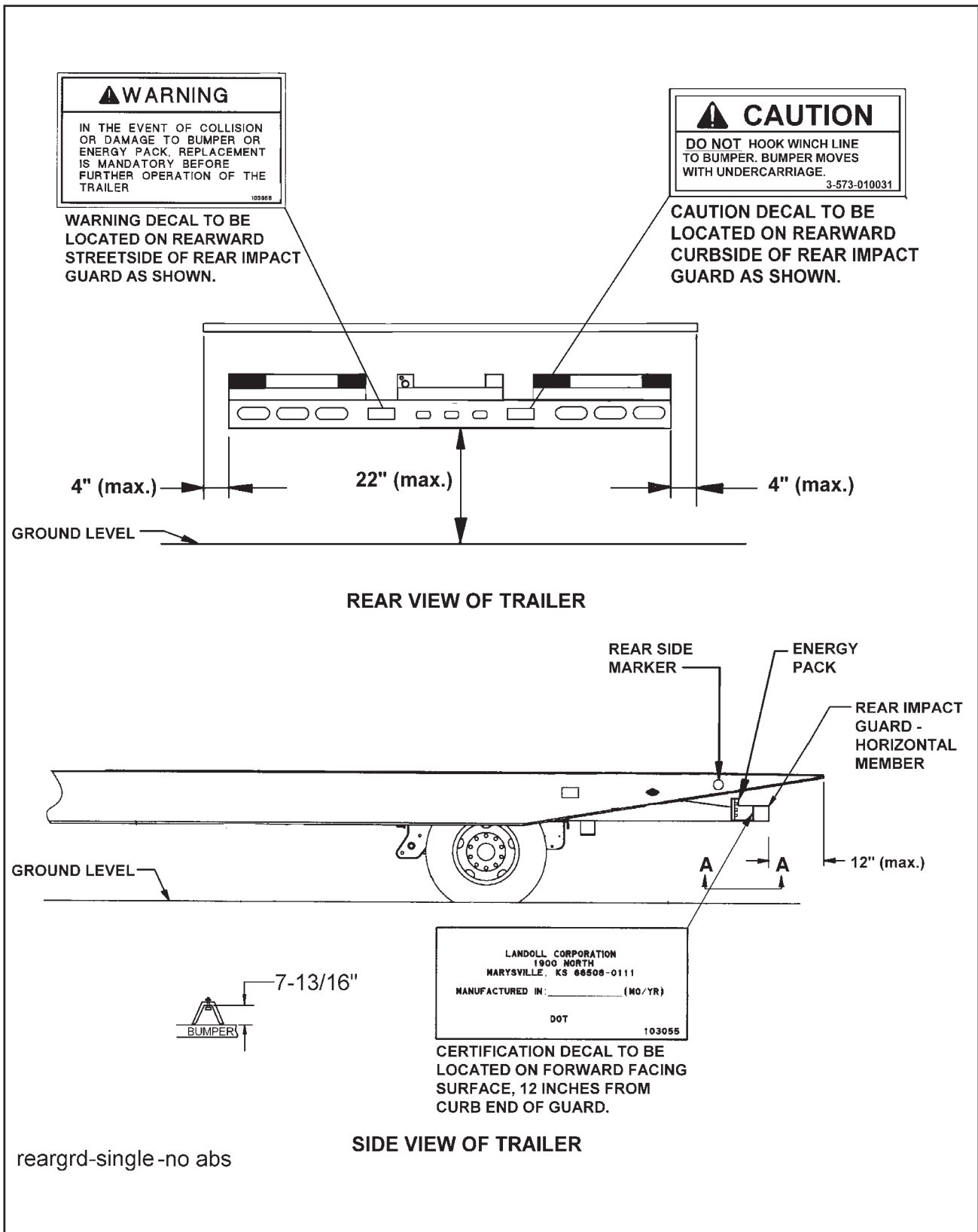

Figure 3-12 Rear Impact Guard System

3-17 REAR IMPACT GUARD SYSTEM

Vehicle standards FMVSS No. 224, Rear Impact Protection, requires all semitrailers manufactured after January 26, 1998 shall be equipped with a rear impact guard certified by the manufacturer as meeting FMVSS No. 223, Rear Impact Guards. The guard, or bumper, meets the following requirements:

- a minimum of 4 inches vertical height
- extend laterally to within 4 inches of the sides of the trailer
- have a ground clearance of no more than 22 inches
- be placed no more than 12 inches from the rear of the trailer

The standard also specifies minimum force and energy absorption requirements for the guard. A DOT decal certifies that the guard meets FMVSS No. 223 and 224 standards. The decal is placed **and must remain at all times** on the forward facing surface of the guard, 12 inches inboard of the curb side and of the guard. See Figure 3-12 for location of decals.

Replace any component that does not allow the above minimum requirements to be met. Any hardware that holds the rear impact guard and becomes damaged or becomes loose shall be removed and replaced. The 3/4" grade 8 screws that hold the bumper energy pack shall be loctited and torqued to 280 ft.-lbs.

DANGER

ALWAYS CHECK THE CONDITION OF THE REAR BUMPER ENERGY PACK. IF PACK HAS BEEN DAMAGED, IT MUST BE REPLACED. FAILURE TO MAINTAIN ENERGY PACK MAY RESULT IN INJURY OR DEATH TO OTHERS.

3-18 BLEEDING AND ADJUSTING THE BRAKES

- 3-18.1** It is typically much easier to bleed the brakes with two people working together.
- 3-18.2** Special care must be taken to insure that the electric/hydraulic unit does not run out of brake fluid. Check the fluid level frequently during the bleeding process.
- 3-18.3** Block the wheels on the trailer and towing vehicle.
- 3-18.4** If the trailer is equipped with drum brakes, check that the brake running clearances are properly adjusted consistent with the trailer manufacturer's recommendations. Even the slightest amount of brake drag will generate heat and will damage the trailer brake system voiding the manufacturer's warranty.

⚠ CAUTION

EYE PROTECTION SHOULD BE WORN AT ALL TIMES WHILE BLEEDING THE ELECTRIC/HYDRAULIC UNIT AND TRAILER BRAKE SYSTEM.

- 3-18.5** Remove the dust cap from the bleed screw on the electric/hydraulic unit and install plastic tubing onto the bleeder (See Figure 3-13).

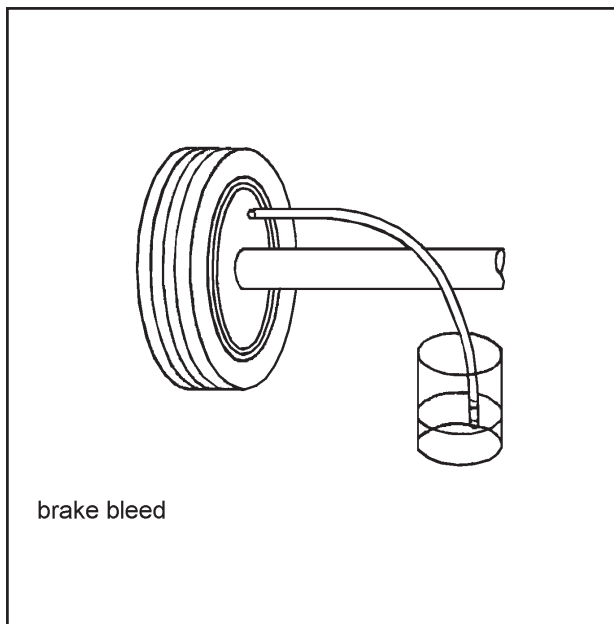

Figure 3-13 Brake Bleed Operation

- 3-18.6** Immerse the free end of the plastic tubing in a clean container partially filled with brake fluid.
- 3-18.7** With eye protection on, open the bleeder screw one half turn on the electric/hydraulic unit. Take care to protect yourself and the trailer from brake fluid expelled from the bleeder.
- 3-18.8** Activate the electric/hydraulic unit by turning on the ignition switch and pressing on the brake pedal or the manual control on the in-cab controller.
- 3-18.9** Watch the free end of the bleeder hose for air bubbles escaping into the container.
- 3-18.10** Continue to bleed until the fluid becomes clear and free of bubbles.
- 3-18.11** Tighten the bleeder screw, turn off the electric/hydraulic unit, and remove the plastic tubing from the bleeder screw. Bleeding of the electric/hydraulic unit is now complete.
- 3-18.12** Install plastic tubing onto the bleeder screw of the wheel cylinder/caliper.
- 3-18.13** Immerse the free end of the plastic tube in a clean container partially filled with brake fluid.
- 3-18.14** With eye protection on, open the bleeder screw one half turn on the wheel cylinder/caliper farthest from the electric/hydraulic unit.
- 3-18.15** Activate the electric/hydraulic unit by turning the ignition switch on and pressing on the brake pedal.
- 3-18.16** Watch the free end of the bleeder hose for air bubbles escaping into the clear container. Continue to bleed the wheel cylinder/caliper until the fluid becomes clear and free of bubbles.

CAUTION

DO NOT RUN THE ELECTRIC/HYDRAULIC UNIT WITHOUT ADEQUATE BRAKE FLUID IN THE RESERVOIR AS IT WILL DAMAGE THE UNIT AND VOID THE MANUFACTURER'S WARRANTY. CHECK ALL BLEEDER SCREWS TO ENSURE THAT THEY ARE SECURELY CLOSED AND DO NOT LEAK.

- 3-18.17** Tighten the bleeder screw, turn off the electric/hydraulic unit, and remove plastic tubing from the bleeder screw. Bleeding of the wheel cylinder/caliper is now complete.
- 3-18.18** Refill the electric/hydraulic unit with brake fluid.
- 3-18.19** Continue **Steps 3-18.12 thru 3-18.18** on the next farthest brake away from the electric/hydraulic unit. Repeat until all brakes have been bled.

WARNING

FAILURE TO PROPERLY ADJUST THE TRAILER BRAKES AND TO PROPERLY FILL AND BLEED THE ELECTRIC/HYDRAULIC UNIT AND BRAKES MAY RESULT IN SLUGGISH BRAKE PERFORMANCE. THIS MAY RESULT IN SERIOUS OR FATAL INJURIES AND/OR PROPERTY DAMAGE. AS A PRECAUTIONARY MEASURE, BLEED BRAKES A SECOND TIME AFTER THE TRAILER HAS BEEN IN SERVICE FOR 7 - 10 DAYS. CHECK THE TEMPERATURE OF THE HUBS ON A REGULAR BASIS TO INSURE THAT THE TRAILER BRAKES ARE NOT DRAGGING.

3-19 INSTALLATION AND ADJUSTMENT OF ELECTRONIC BRAKE CONTROL

IMPORTANT

DO NOT MOUNT OR ACTIVATE RF GENERATING ITEMS (CELL PHONES, TWO WAY RADIOS) NEAR (LESS THAN 12") THE BRAKE CONTROL.

REVERSING THE CONNECTION TO A BREAK-A-WAY BATTERY ON THE TRAILER WILL DESTROY THE BRAKE CONTROL.

DISCONNECT TRAILER PLUG FROM THE TOW VEHICLE PRIOR TO TESTING A BREAK-A-WAY SWITCH, OR THE BRAKE CONTROL MAY BE DESTROYED.

THE LIGHT IS:

- **GREEN WHEN TRAILER IS CONNECTED**
- **RED WHEN BRAKE PEDAL OR MANUAL SLIDE KNOB ON BRAKE CONTROL IS ACTIVATED AND TRAILER IS CONNECTED.**

THE GREEN LIGHT DRAWS 10 MILLIAMPERES OF CURRENT FROM TOW VEHICLE. IT WOULD TAKE OVER 5,000 HOURS TO DRAIN THE TOW VEHICLE BATTERY.

THE LEVEL ADJUSTMENT IS CRITICAL. THE LEVEL ADJUSTMENT DETERMINES WHETHER AUTOMATIC BRAKING RESPONSE IS DELAYED OR AGGRESSIVE.

THIS BRAKE CONTROL IS ACTIVATED BY INERTIA. IT SENSES DECELERATION AND GENERATES AN OUTPUT THAT REFLECTS THE INERTIA SENSED. IN A STATIONARY STATE, THE BRAKE CONTROL WILL NOT APPLY THE TRAILER BRAKES UNLESS THE MANUAL SLIDE KNOB IS ACTUATED.

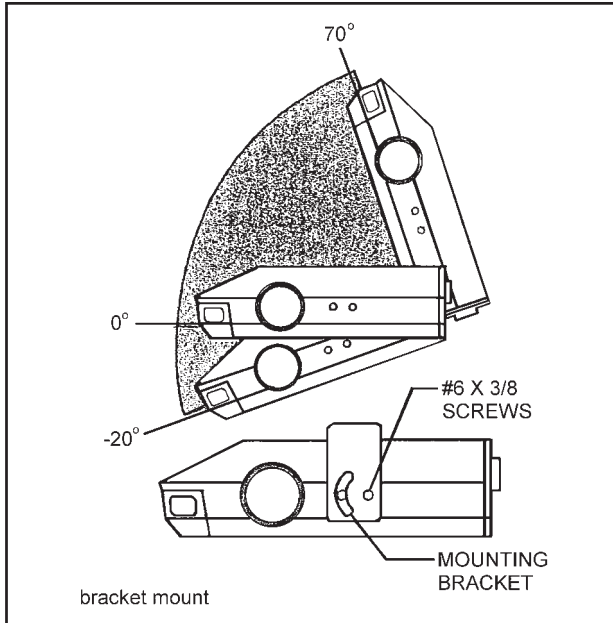

Figure 3-14 Mounting Bracket Installation

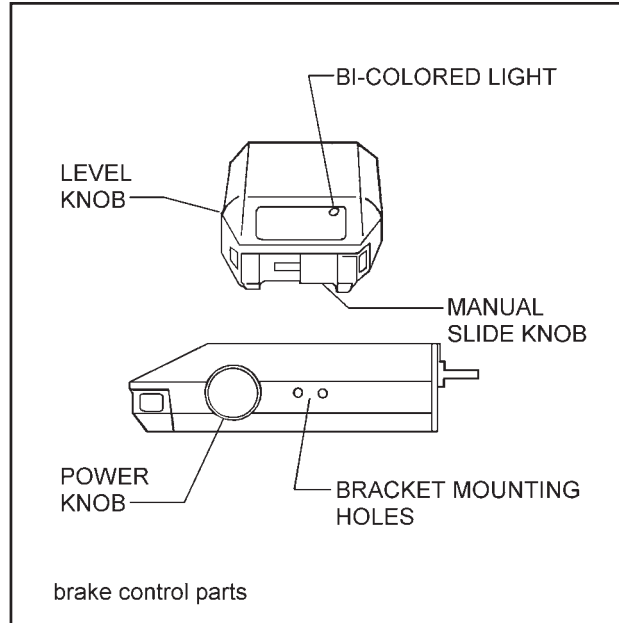

Figure 3-15 Brake Control Components

3-19.1 Installation

IMPORTANT

THE BRAKE CONTROL MUST BE MOUNTED FROM -20° NOSE DOWN TO 70° NOSE UP. FAILURE TO INSTALL BRAKE CONTROL WITHIN THESE CONSTRAINTS MAY CAUSE YOUR CONTROL TO BECOME INOPERABLE (SEE FIGURE 3-14).

- a. Securely mount bracket to a solid surface.
- b. Insert supplied #6 x 3/8" screws on each side into the mounting holes.
- c. Adjust control to desired position and tighten screws until snug.

IMPORTANT

DRILLING OR USE OF LONGER SCREWS MAY DAMAGE UNIT.

3-19.2 Leveling the Sensor

IMPORTANT

THIS BRAKE CONTROL IS ACTIVATED BY INERTIA AND REQUIRES THE LEVEL TO BE SET PROPERLY, OR THE BRAKING RESPONSE WILL BE TOO HARSH OR INEFFECTIVE.

TO PROPERLY LEVEL THE SENSOR, THE TRAILER AND TOW VEHICLE MUST BE PARKED ON A LEVEL SURFACE AND TRAILER MUST BE CONNECTED TO TOW VEHICLE.

- a. Connect trailer to tow vehicle. The bi-colored light should glow GREEN (See Figure 3-15).
- b. Set power knob to maximum by fully rotating clockwise.
- c. Depress tow vehicle's brake pedal and hold.
- d. Rotate the level knob counter-clockwise (towards the back of the control) until the bi-colored light starts to change colors from GREEN to RED.
- e. Carefully rotate the level knob clockwise (towards the front of the control) until a shade of ORANGE is visible.
Bi-colored light should show:
 1. DIM ORANGE for a typical setting
 2. BRIGHT ORANGE for an aggressive setting
 3. DIM RED for a more aggressive setting

IMPORTANT

RANGE OF ADJUSTMENT FOR THE LEVEL KNOB FROM DIM ORANGE TO DIM RED IS 20 DEGREES OF ROTATION.

3-19.3 Release brake pedal.

IMPORTANT

WHEN THE BRAKE CONTROL IS LEVELED PROPERLY THERE WILL BE VERY LITTLE CURRENT FLOWING THROUGH THE CIRCUIT IN A STATIC STATE WITH THE FOOT PEDAL DEPRESSED. ANYTIME THE BI-COLORED LIGHT SHOWS ANY COLOR OTHER THAT GREEN, THERE IS CURRENT FLOWING THROUGH THE CIRCUIT.

3-19.4 Adjusting the Power to the Trailer Brakes

Once the control has been installed and properly leveled, it is necessary to set the power needed to stop the trailer during a braking event.

- a. Connect trailer to tow vehicle.
 - b. Set power knob to the 12 o'clock position.
 - c. Drive tow vehicle and trailer on a dry level paved surface at 25 mph and apply manual slide knob.
- **IF TRAILER BRAKES LOCK UP: TURN POWER DOWN USING POWER KNOB. (ROTATE POWER KNOB TOWARD THE 8 O'CLOCK POSITION, COUNTER-CLOCKWISE).**
 - **IF BRAKING WAS NOT SUFFICIENT: TURN THE POWER UP USING POWER KNOB. (ROTATE POWER KNOB TOWARD THE 5 O'CLOCK POSITION, CLOCKWISE).**
 - d. Repeat **Section 3-19.4c.** until power has been set to a point just below wheel lock up or at a sufficient force as to achieve maximum braking power.
 - e. Using the brake pedal, make a few low speed stops to check the power and level adjustments. The automatic response (brake pedal) is initiated and terminated via the stop-light switch. When the brake pedal is released, trailer braking will cease.

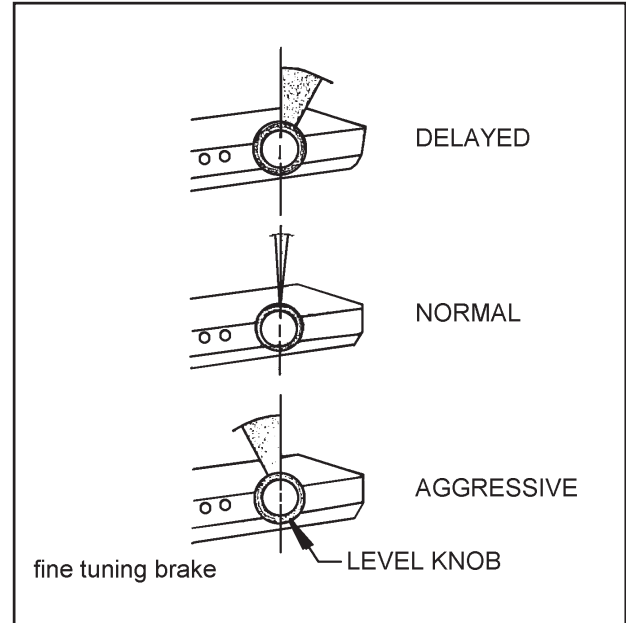

Figure 3-16 Fine Tuning Brake

3-19.5 Fine Tuning

Now that the power has been set, it is time to fine turn the level setting for the majority of the stopping that you will be doing.

- a. Make several slow (25 mph) stops as if coming up to a stop sign and take notice of how the trailer brakes respond:
- **IF BRAKES GRAB TOO MUCH: YOU HAVE AN AGGRESSIVE SETTING. TO CORRECT THIS CONDITION, ROTATE LEVEL KNOB CLOCKWISE, TOWARD YOU (SEE FIGURE 3-16).**
 - **IF TRAILER TENDS TO PUSH TOWING VEHICLE: YOU HAVE A DELAYED SETTING. TO CORRECT THIS CONDITION, ROTATE LEVEL KNOB COUNTER-CLOCKWISE, AWAY FROM YOU (SEE FIGURE 3-16).**
 - b. Repeat **Section 3-19.5a.** until desired trailer braking is achieved.

IMPORTANT

ALWAYS WARM THE TRAILER'S BRAKES BEFORE SETTING THE POWER. WARM TRAILER BRAKES TEND TO BE MORE RESPONSIVE THAN COLD BRAKES. TO WARM TRAILER BRAKES, DRIVE A SHORT DISTANCE (1/4 MILE) AT 45 MPH WITH MANUAL SLIDE ENGAGED APPROXIMATELY HALFWAY.

THE POWER SHOULD NEVER BE AT A LEVEL HIGH ENOUGH TO CAUSE TRAILER BRAKES TO LOCK UP. SKIDDING TRAILER WHEELS CAN CAUSE LOSS OF DIRECTIONAL STABILITY OF TRAILER AND TOW VEHICLE.

THE POWER MAY NEED TO BE ADJUSTED FOR DIFFERENT LOAD WEIGHTS AND ROAD CONDITIONS.

NOT ALL TRAILER BRAKES WILL LOCK UP DUE TO VARIOUS CONDITIONS.

WHEN THE LEVEL AND POWER ARE SET CORRECTLY, YOU SHOULD FEEL UNIFIED BRAKING BETWEEN THE TRAILER AND TOW VEHICLE.

BRAKING PERFORMANCE MAY BE SLIGHTLY SLUGGISH IN SUB-FREEZING TEMPERATURES. ALLOW ADEQUATE TIME FOR THE BRAKE CONTROL TO WARM PRIOR TO USE IN SUB-FREEZING TEMPERATURES.

WHEN IN DOUBT OF THE PROPER SETTING PROCEDURES, REVIEW SECTIONS 3-19.2 THRU 3-19.5 OR CONSULT YOUR TOW CARD INCLUDED WITH YOUR BRAKE CONTROL.

3-20 RADIO REMOTE CONTROL OPERATION

3-20.1 A wireless radio remote control is a triple function (See Figure 3-17).

3-20.2 The remote operates any of the hydraulic functions that are desired. The remote components are connected to the hydraulic valve section that the remote is desired to operate. The electrical switches operate the functions of the hydraulic spool valve instead of operating the control levers on the valve.

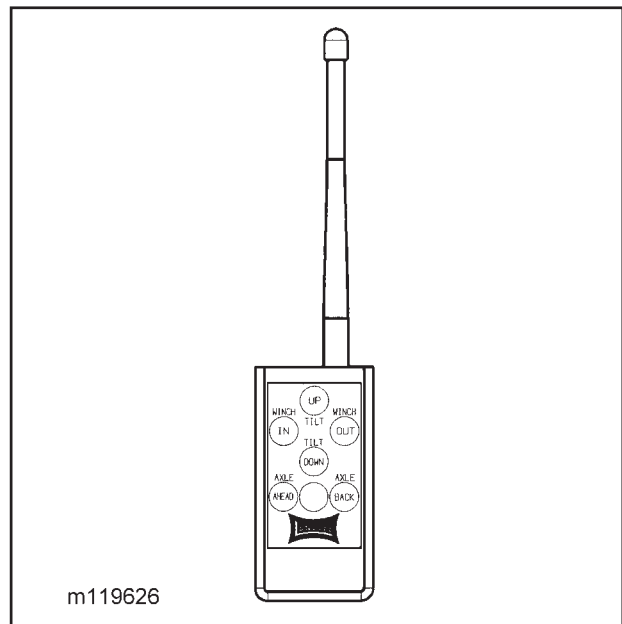

Figure 3-17 Radio Remote Control

3-21 COLD WEATHER OPERATION

- 3-21.1** Cold weather causes lubricants to congeal, insulation and rubber parts to become hard, which may lead to problems found in bearings, electrical systems, and hydraulic systems. Moisture attracted by warm parts can condense, collect and freeze to immobilize equipment. The truck/trailer operator must always be alert for indicators of cold weather malfunctions.
- 3-21.2** During any extended stop period, neither the service nor parking brake should be used as they can freeze up. Use wheel chocks to secure the vehicle from moving.
- 3-21.3** Check all structural fasteners, hydraulic system fittings, gaskets, seals and bearings for looseness that can develop due to contraction with cold. Do not over-tighten.
- 3-21.4** Check tire inflation. Tire inflation decreases when the temperature decreases.
- 3-21.5** Periodically check drain holes in the bottom of storage compartments. They must be open at all times to avoid moisture entrapment.

3-22 HOT WEATHER OPERATION

- 3-22.1** Hot weather operation can cause expansion of parts, resulting in tightening of bearings, fasteners, and moving parts. Failure of gaskets or seals can occur.
- 3-22.2** The trailer should be parked in the shade if possible. Long exposure to the sun will shorten service life of rubber components (i.e., tires, light and hose grommets, hoses, etc.) and paint life.
- 3-22.3** Check tire pressure early in the day before beginning operations while the tire is cool. Put all valve stem caps back on after checking.
- 3-22.4** If the area is extremely humid, protect electrical terminals with ignition insulation spray. Coat paint and bare metal surfaces with an appropriate protective sealer.

This section contains instructions necessary for proper maintenance of the semitrailer. The 341 semitrailer is designed for years of service with minimal maintenance. However, proper maintenance is important for durability and safe operation and is an owner/user responsibility.

DANGER

OPERATING THE TRACTOR OR SEMI-TRAILER WITH DEFECTIVE, BROKEN OR MISSING PARTS MAY RESULT IN SERIOUS INJURY OR DEATH; DAMAGE TO THE TRACTOR/TRAILER, ITS CARGO, OR PROPERTY IN ITS PATH.

4-1 MAINTENANCE SCHEDULE

Semitrailer maintenance includes periodic inspection and lubrication. **Table 4-2, Maintenance Schedule**, lists the recommended maintenance and lubrication tasks by time interval and by accumulated mileage (use whichever occurs first). **Table 4-3, Hydraulic Engine Maintenance Schedule**, lists the recommended maintenance tasks for the hydraulic engine package.

4-1.1 Inspection

- a. Inspect the truck, the semitrailer, and semitrailer parts periodically for damage or signs of pending failure. Damaged or broken parts must be repaired or replaced at once. Determine the cause of any binding or hydraulic leakage at once. Correct the problem before using the truck or semitrailer.
- b. Use the Troubleshooting Guide to check for "SYMPTOMS" and "PROBLEMS" of any semitrailer system not functioning correctly, or where wear, distortion, or breakage are found. Administer "REMEDY" according to the right-hand column of the Troubleshooting Guide.

4-1.2 Lubrication

Figure 4-1 and Table 4-1 details lubrication points and intervals, method of application, and lubricant required, and illustrates the location of each part to be lubricated. During inspections of the semitrailer, if lubricants are found to be fouled with dirt or sand, those parts should be cleaned with paint thinner, dried, and relubricated immediately. Dirt in a lubricant forms an abrasive compound that will wear parts rapidly.

WARNING

PAINT THINNER AND OTHER SOLVENTS ARE FLAMMABLE AND TOXIC TO EYES, SKIN, AND RESPIRATORY TRACT. AVOID SKIN AND EYE CONTACT. GOOD GENERAL VENTILATION IS NORMALLY ADEQUATE. KEEP AWAY FROM OPEN FLAMES OR OTHER COMBUSTIBLE ITEMS.

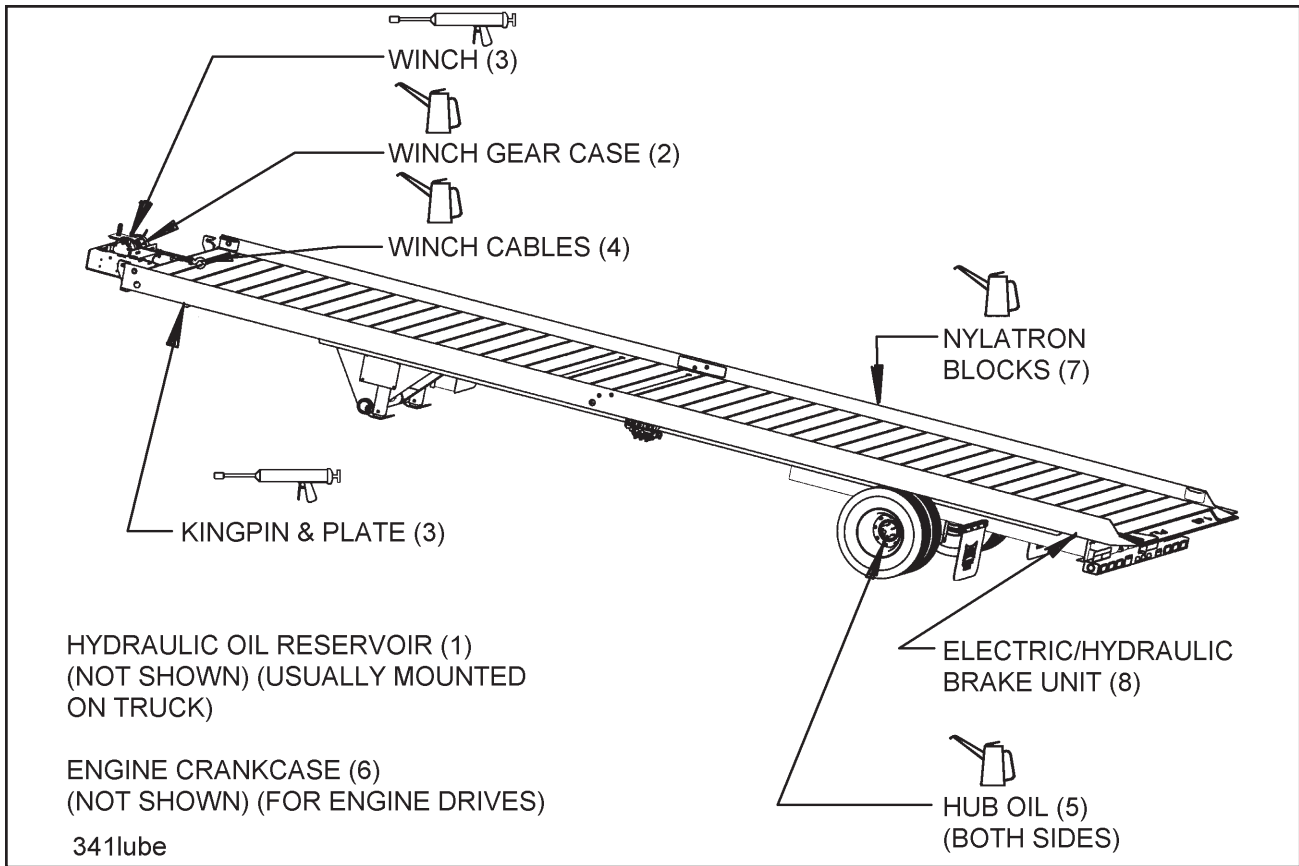

Figure 4-1 Lubrication Points

LUBE	SEASON	BRAND AND PRODUCT (WEIGHT AND/OR TYPE)			
		AMOCO	EXXON	PHILLIPS	TEXACO
1	ALL YEAR	Rycon MV	HDX Plus 10W	Mangus Oil A KV 5W-20	Rando HD-AZ
2	SUMMER	Permagear EP 460 SAE 140	Spartan 460 SAE 140	Phil Gear Lube 460 SAE 140	Meropa 460 SAE 140
	WINTER	Permagear EP 220 SAE 90	Spartan 220 SAE 90	Phil Gear Lube 220 SAE 90	Meropa 220 SAE 90
3	ALL YEAR	Lit-Multi-purpose Grease	Rondex Multi-purpose Grease	Phil Lube M.W. Grease	MarFax All Purpose
4	ALL YEAR	Industrial Oil 32	Estic 32	Condor 32 or Magnus 32	Regal Oil R&O 32
5	ALL YEAR	Gear Lube SAE 80W-90	Gear Oil GX SAE 80W-90	Superior MP Gear Oil SAE 80W-90	Multi-gear EP SAE 80W-90
6	ABOVE 0° F	Ultimate Gold 10W-30, 10W-40	SuperFlow 10W-30, 10W-40	Tropartic 10W-30, 10W-40	Havoline 10W-30, 10W-40
	BELOW 32° F	Ultimate Gold 5W-20, 5W-30	SuperFlow 5W-20, 5W-30	Tropartic 5W-20, 5W-30	Havoline 5W-20, 5W-30
7	USE A SPRAY ON LUBRICATING OIL WHICH IS NOT STICKY SO IT DOES NOT ATTRACT DIRT AND GRIT.				
8	DOT 3 OR DOT 4 BRAKE FLUID				

Table 4-1 Lubrication Specifications

NORMAL OPERATING SERVICE INTERVALS ^a									
SERVICE INTERVAL : ITEM	TIMES	Before Every Use	1st 5 Hrs	Weekly	Monthly	6 Months	Yearly	LUBE #	NOTES
	MILES		50	500	2,000	12,000	25,000		
LIGHTS			I	I					
WIRING & CONNECTIONS			I		I				
FASTENERS			I, T		I				b
KING PIN & PLATE			I		C, I, L			3	c
HYDRAULIC BRAKE RESERVOIR			I			I		8	g
BRAKE ADJ & WEAR			I		I, T				d
BRAKE LININGS							I		
HUB OIL			I	I, L			R	5	c
WHEEL BEARINGS/CUPS							I	5	c
TIRE INFLATION & WEAR			I	I					e
WHEEL LUG NUTS			I, T	I	I, T				f
SUSPENSION ALIGNMENT			I		I				
U/C NYLATRON SLIDES					L			7	c
HYDRAULIC OIL			I	I			R	1	c
HYDRAULIC FILTER			R			R			
HOSES			I		I				
TRAILER BRAKE WIRING						I			
BREAK-A-WAY SYSTEM		I							
BRAKE CONTROLLER		I							
BRAKE CYLINDERS							I		
BRAKE LINES							I		
TIRE INFLATION PRESSURE				I					
TIRE CONDITION					I				
HUB AND DRUM							I		

I – Inspect, R – Replace, T– Tighten/ Adjust Torque, L – Lubricate, C – Clean

NOTES:

- Perform at the time shown. Shorten service intervals when operating in severe or dirty conditions.
- See **Tables 2-1 and 2-2 (General and Hydraulic Fitting Torque Charts)** for correct torque.
- See **Table 4-1 (Lube Specification Chart)** for recommended lubricant.
- Call Landoll Customer Services for procedures to replace.
- See Serial Number Plate on the front of the semitrailer for proper inflation requirements.
- See **Figure 4-13**, Stud Tightening Sequence.
- Fill hydraulic brake reservoir to the bottom of the reservoir filler neck. When putting filler cap back on it should be turned clockwise until snug.

Table 4-2 Maintenance Schedule

ENGINE MAINTENANCE SCHEDULE							
OPERATION	AFTER EACH CYCLE OF INDICATED HOURS						
	8	25	50	100	200	500	1000
Inspect Engine Generally	X ¹						
Check Oil Level	X						
Service Air Cleaner Element And Element Wrapper		X ²					
Change Crankcase Oil (20 hp engine)		X ³	X ²				
Change Crankcase Oil (24 hp engine)		X ³		X ²			
Replace Oil Filter		X ³		X ²			
Check Battery Electrolyte Level			X				
Clean Cooling Fins			X ²				
Replace Air Cleaner Element					X ²		
Replace Fuel Filter					X		
Check or Replace Spark Plugs						X	
Check Valve Clearance							X ⁴
Clean Carbon and Lead Deposits (cylinder head)							X ⁵
NOTES:							
X ¹ . Check for fuel leaks. With engine running, visually and audibly check exhaust system for leaks.							
X ² . Perform more often when running under severe operating conditions.							
X ³ . Required for initial break-in only.							
X ⁴ . For detailed maintenance, contact a service center or refer to the Service Manual.							
X ⁵ . Clean carbon more frequently when running under continuous light load and/or on leaded fuel. Use of carburetor and combustion cleaner is recommended every 200 hours to help reduce carbon buildup.							

WARNING

BREATHING EXHAUST GASES CAN RESULT IN SEVERE PERSONAL INJURY OR DEATH. DO NOT USE AIR CLEANER, EXHAUST ELBOW, OR CONNECTING PARTS AS A SUPPORTING STEP. DAMAGE TO THESE AND CONNECTING PARTS CAN CAUSE AN EXHAUST LEAK.

Table 4-3 Hydraulic Engine Maintenance Schedule

4-2 MAINTENANCE PROCEDURES

4-2.1 Tools and Equipment. Tools, equipment, and personnel normally found in a facility capable of making truck repairs will be adequate for maintenance of the semitrailer. No other special tools or equipment should be necessary.

4-2.2 Standard Torque Values. Tables 2-1 and 2-2 lists torque values for standard hardware and is intended as a guide for average applications involving typical stresses and mechanical surfaces. Values are based on the physical limitations of clean, plated, and lubricated hardware. In all cases, when an individual torque value is specified, it takes priority over values given in this table. Replace original fasteners with hardware of equal grade.

WARNING

PAINT THINNER AND OTHER SOLVENTS ARE FLAMMABLE AND TOXIC TO EYES, SKIN, AND RESPIRATORY TRACT. AVOID SKIN AND EYE CONTACT. GOOD GENERAL VENTILATION IS NORMALLY ADEQUATE. KEEP AWAY FROM OPEN FLAMES OR OTHER COMBUSTIBLE ITEMS.

WARNING

DO NOT ALLOW ALUMINUM BRIGHTENER OR OTHER ACID COMPOUNDS TO CONTACT HYDRAULIC HOSES. THE HOSE COVERS ARE SUSCEPTIBLE TO ACID DETERIORATION.

4-2.3 Cleaning

- a. Wash semitrailer to remove all accumulated dirt and grime.
- b. Use any mineral spirits paint thinner (or its equivalent) to remove grease and oil from all parts of the semitrailer. Rinse degreasing solution off with cold water.
- c. For washing aluminum, use water and a mild, non-abrasive soap or detergent such as those recommended for automotive finishes. Rinse with clear water. The aluminum can be waxed with a liquid or paste wax recommended for the care of automotive finishes, if desired.
- d. Inspect semitrailer for cause of any reported troubles.
- e. Scrape, sand, prime, and repaint areas where finish is missing or where there is evidence of corrosion.
- f. After disassembling any components, thoroughly clean dirt and old lubricant from all parts. Do not use a wire brush on any bearing parts or surfaces — use a stiff bristle brush. Do not use compressed air, or spin bearing parts when cleaning. These practices can throw solvents, dirt, or metal particles into your eyes. Dry clean parts with lint free, clean, soft, absorbent, cloth or paper. Wash and dry hands.
- g. Inspect seals, seal wiping surfaces, bearing caps, and bearing cones for wear, pitting, chipping, or other damage.

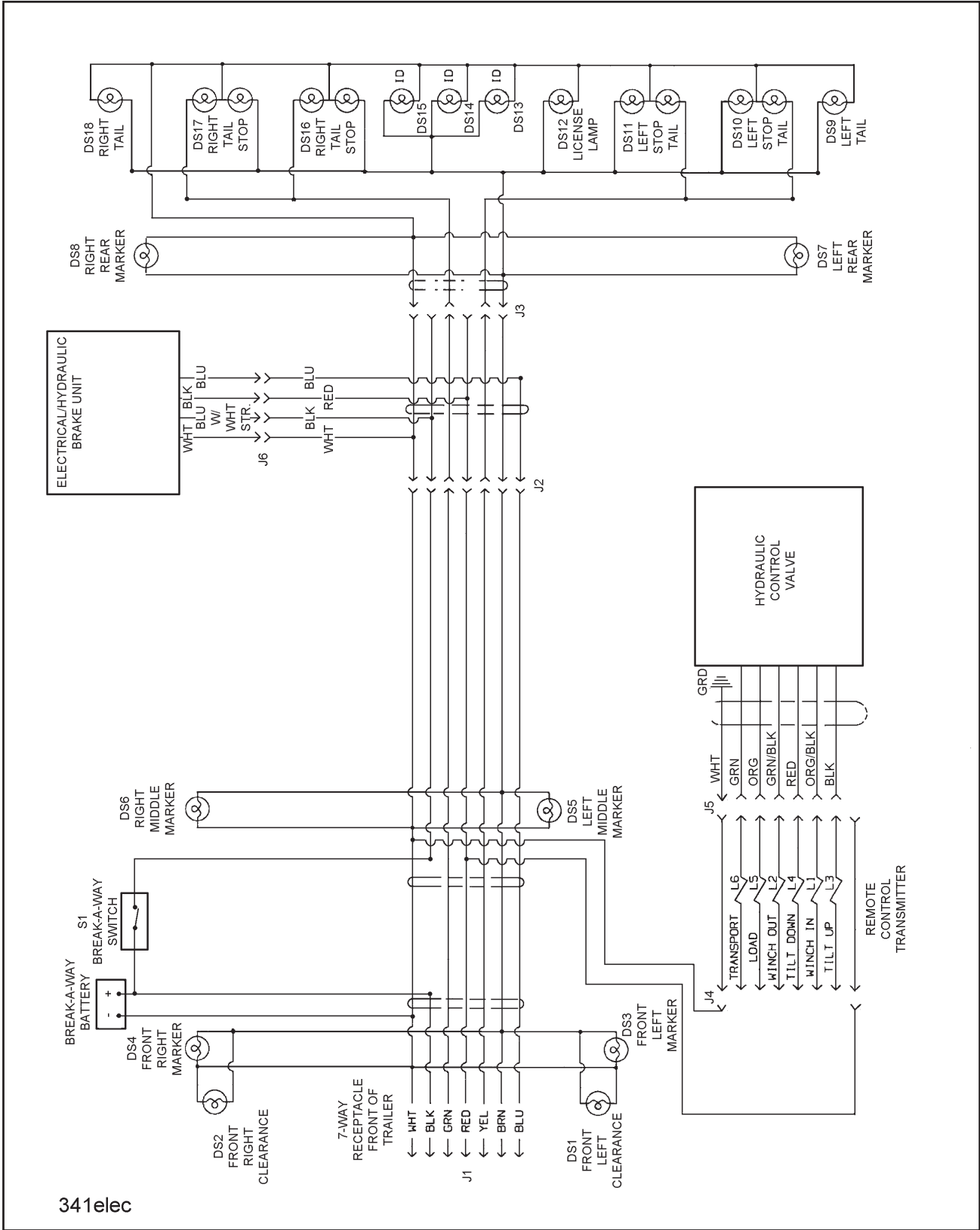

341elec

Figure 4-2 341 Trailer Wiring Diagram

341 TRAILER WIRING PARTS LIST		341 TRAILER WIRING PARTS LIST	
REF. DES.	FUNCTION	REF. DES.	FUNCTION
DS1	FRONT LEFT CLEARANCE, YELLOW	DS15	IDENTIFICATION CENTER, RED
DS2	FRONT RIGHT CLEARANCE, YELLOW	DS16	RIGHT TURN, STOP/TAIL, RED
DS3	FRONT LEFT MARKER, YELLOW	DS17	RIGHT TURN, STOP/TAIL, RED
DS4	FRONT RIGHT MARKER, YELLOW	DS18	RIGHT TAIL, RED
DS5	LEFT MIDDLE MARKER, YELLOW	J1	FRONT MAIN CONNECTOR
DS6	RIGHT MIDDLE MARKER, YELLOW	J2	U/C CONNECTOR
DS7	LEFT REAR MARKER/TURN, RED	J3	BUMPER CONNECTOR
DS8	RIGHT REAR MARKER/TURN, RED	J4	REMOTE CONTR.PWR/GRND CONN
DS9	LEFT TAIL, RED	J5	GRD & FUNCTION CONNECTION TO SOLENOID VALVES
DS10	LEFT TURN STOP/TAIL, RED	L1	WINCH IN
DS11	LEFT TURN, STOP/TAIL, RED	L2	WINCH OUT
DS12	LICENSE PLATE LIGHT	L3	TILT UP
DS13	IDENTIFICATION RIGHT, RED	L4	TILT DOWN
DS14	IDENTIFICATION LEFT, RED		

Figure 4-3 341 Trailer Wiring Parts List

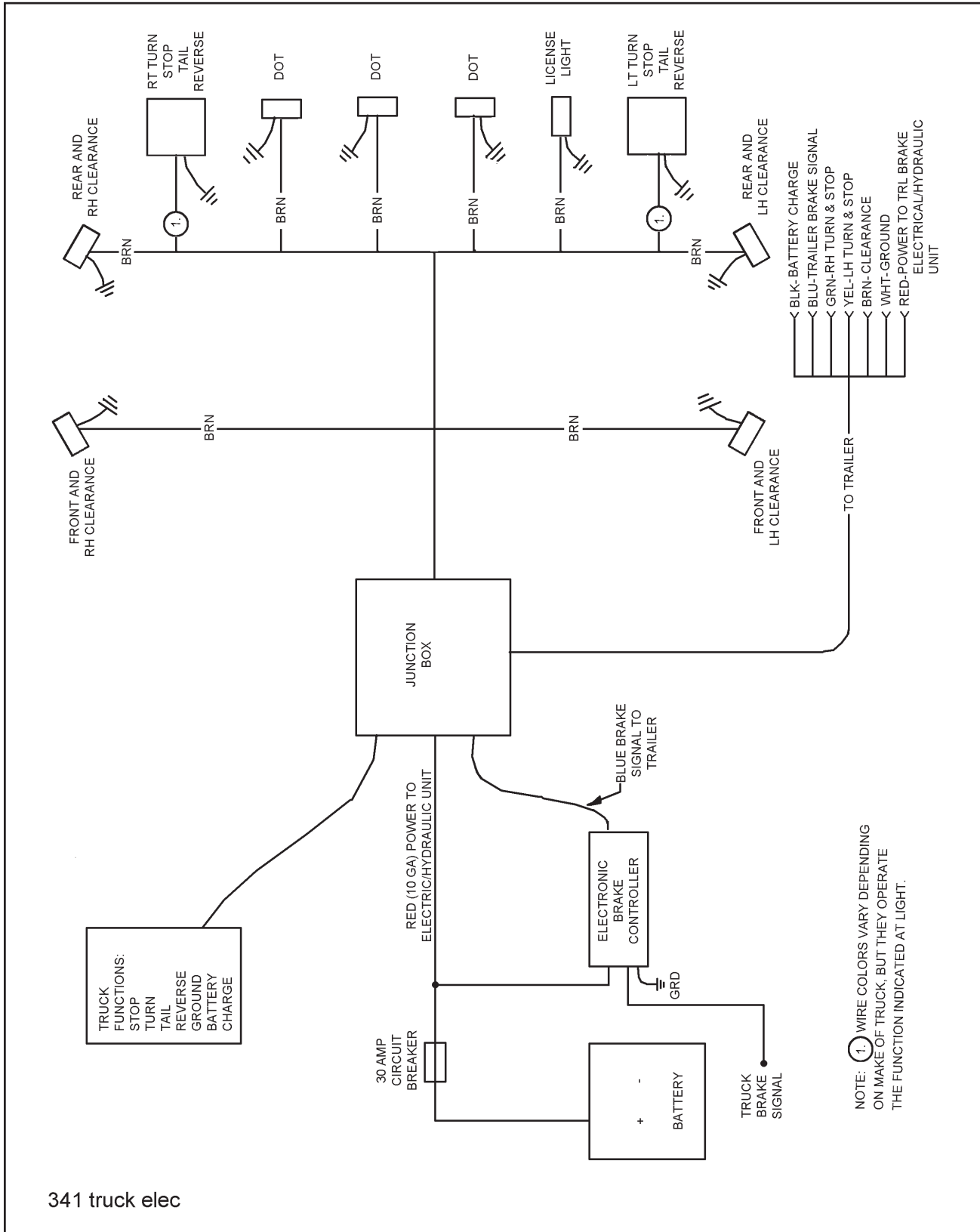

341 truck elec

Figure 4-4 Truck Wiring Diagram

4-3 HITCH, FRAME, AND DECK

4-3.1 Repairing Structural Defects

If any structural defect is found, the fault must be corrected before further use of the vehicle. To continue usage could endanger the semitrailer, its load, personnel, traffic, and properties. Inspect the deck daily for broken or missing planks or missing attachments. Replace any defective parts promptly.

4-4 HYDRAULIC SYSTEM

4-4.1 General

- a. Check the oil level of the truck wet kit hydraulic tank weekly, or after any leakage. See **Table 4-1** for proper hydraulic oil. Check the hydraulic oil level with hydraulic cylinders in the retracted position. Disengage the hydraulic pump.
- b. Overfilling can cause hydraulic fluid overflow during operation.
- c. Hydraulic system pressure relief valves should be set at 2500 PSI.

4-4.2 Hydraulic Engine Package

- a. Check the hydraulic oil level weekly, or after any leakage. See **Table 4-1** for proper hydraulic oil. Check oil level with hydraulic cylinders in the retracted position and with the engine stopped.

- b. Check hoses weekly for cracks or leaks. If a valve or line leaks, it should be replaced immediately.
- c. Check the engine oil each time before using. Oil level should be maintained between the “ADD” and “FULL” marks on the oil dip stick.
- d. Replace hydraulic filter with new filter at least *every 6 months* or more often under adverse conditions.
- e. Use the fuel recommended for the engine package installed on your semitrailer.
- f. For further maintenance procedures and proper lubrication specifications, please refer to the engine owners manual that was supplied with the hydraulic engine package.

4-5 ELECTRICAL SYSTEM

4-5.1 Maintenance of the electrical system consists of inspection and minor servicing. Any wire, connection or electrical component showing signs of corrosion, wear, breakage or unraveling must be repaired or replaced.

4-5.2 Frayed or unraveling wire must have the defective section removed and replaced with wire of the same color and gauge. Seal all connections and insulate.

4-5.3 Corroded terminals must have the corrosion removed, source of corrosion neutralized and the terminals resealed, protected, and insulated.

4-5.4 Fuse or circuit breaker burn-out or blow-out usually indicates an electrical short-circuit, although a fuse can occasionally fail from vibration. Insert a second fuse or reset the breaker. If this fuse immediately burns out or the breaker trips, locate the cause of the electrical short and repair.

4-5.5 A light that repeatedly burns-out usually indicates a loose connection, poor system ground, or a malfunctioning voltage regulator. Locate the source of the problem and repair. System grounds must be grounded to bare metal surfaces. Paint, grease, wax, and other coatings act as insulators. Replacement lamps must be equivalent to the factory installed lamp.

4-6 SUSPENSION MAINTENANCE

4-6.1 Spring Suspension

- a. Make certain that all springs are properly located on the wear pads. Twisted springs or cocked hangers will cause uneven spring contact with wear pad and will result in excessive wear on the spring suspension. Check the shocks for excessive wear.

- b. Replacing the equalizer bushings and the torque arm bushings on the spring suspension is a complex operation and should be left to trained service personnel. If the bushings need to be replaced contact a Landoll authorized service center or the Landoll factory for servicing.

4-7 ALIGNMENT

4-7.1 Wheel Alignment

 DANGER
TO PREVENT A LIFE THREATENING ACCIDENT:
1. SUPPORT TRAILER AND UNDERCARRIAGE SO TIRES ARE OFF THE GROUND.
2. SUPPORT THE TRAILER AND UNDERCARRIAGE ON JACK STANDS WITH SUFFICIENT CAPACITY TO SUPPORT THE TOTAL WEIGHT OF THE TRAILER AND ANY LOAD WHICH IT MAY BE CARRYING.

When trailer tires show signs of scuffing, feather-edging or uneven wear, examine the trailer for damaged suspension (frame, shocks, linkage, etc.), axle, wheel bearings and wheels. Proper wheel alignment and wheel bearing adjustment is essential for proper tire wear. The simplest form of checking wheel alignment "toe" is by running the trailer over a "SCUFF GAUGE". A scuff gauge reading of 16 feet or less per mile is considered satisfactory. If a scuff gauge is not readily available, or edge wear on one side of a tire is occurring signifying positive or negative camber, alignment can be checked as follows:

- a. Remove wheel, hub and bearing assemblies.
- b. Place a 3-point axle gauge against the front side of the axle, and adjust each axle gauge point to the axle. (Double point end against the inner and outer wheel bearing surfaces of the spindle being checked and the other point on the inner bearing surface on the other spindle.) (See Figure 4-6).
- c. Move the axle gauge and place against the back side of the axle. If either of the points of double point end fails to touch the axle surface, a bent spindle is evident. A point gap of .015" or more is considered excessive tire "toe" and the axle must be replaced (See Figure 4-6).
- d. Follow the same procedures as in Section 4-7.1 b. and c., except place the axle gauge above and below the axle. If gauge point gap is found, the axle has positive or negative camber. The trailer axle has no camber from the factory. If it is found to have positive or negative camber, axle replacement is necessary (See Figure 4-5 for examples of camber).

4-7.2 Axle Alignment

Proper axle to king pin alignment is necessary to obtain straight tracking. If axle alignment is off, "dog-tracking" occurs. Check alignment manually or by using a semitrailer alignment machine. In either case, a thorough inspection of the complete suspension must be performed and all defects corrected before aligning.

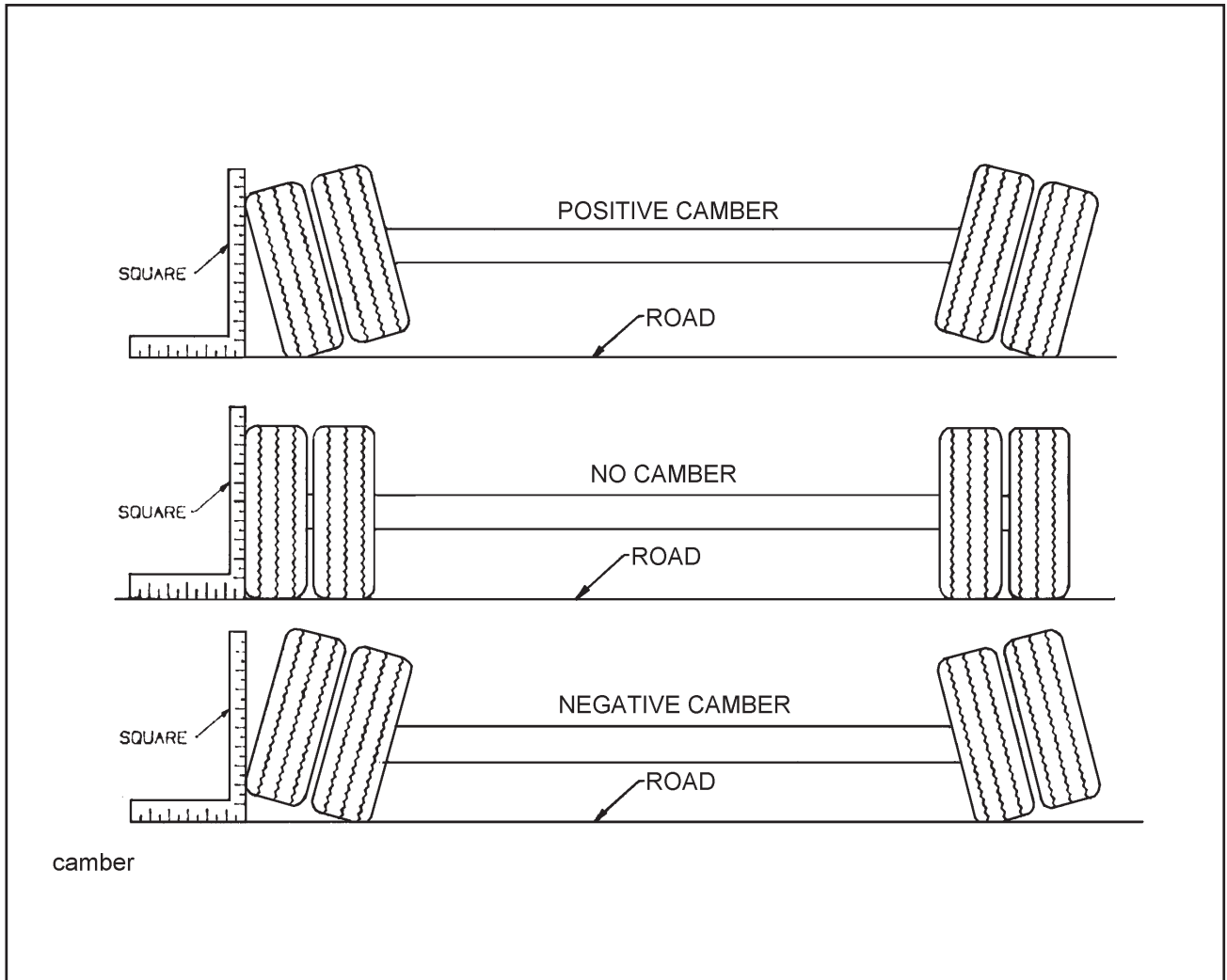

Figure 4-5 Examples of Camber

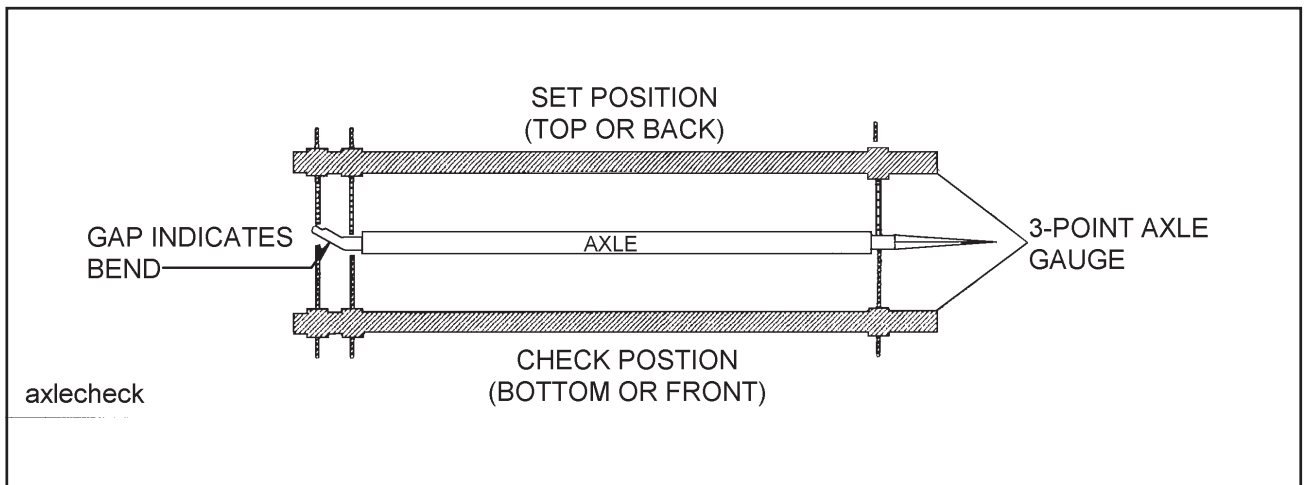

Figure 4-6 Checking Axle for Bend

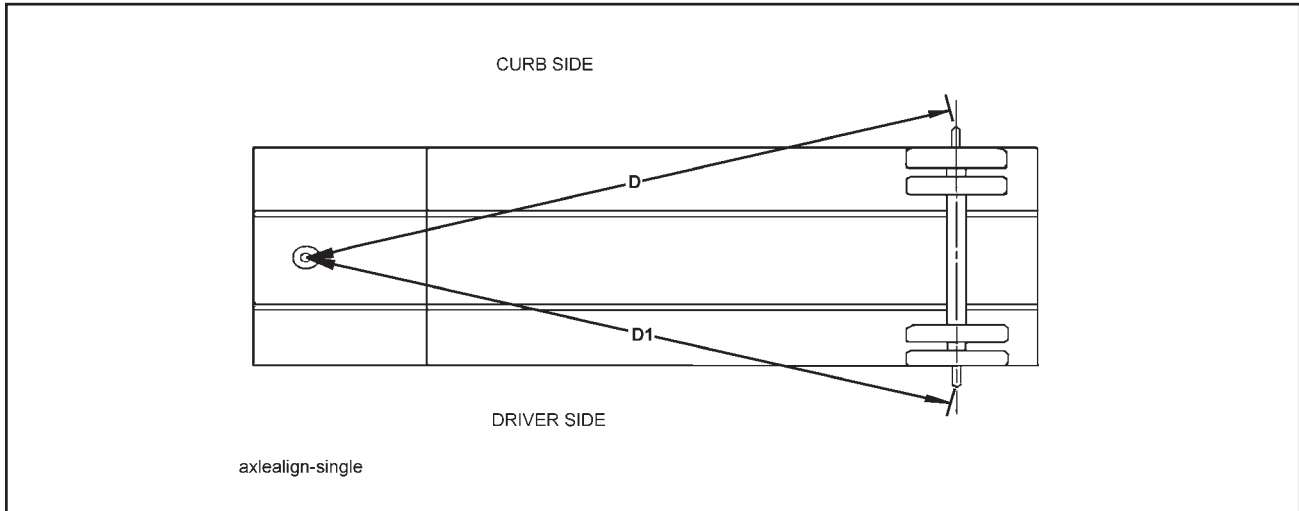

Figure 4-7 Checking Axle Alignment

a. Manual Alignment Procedure

1. Position semitrailer on a firm and level surface. Insure that the undercarriage is in the rear most position. Eliminate any suspension binding due to sharp turns or unusual maneuvers.
2. Detach truck from the semitrailer and jack the trailer up sufficiently to permit measuring from the underside of the trailer.
3. Suspend a plumb bob at axle height from the center of the king pin.
4. Measure (D) from the plumb bob to the center point on one end of the axle. Record this measurement (**See Figure 4-7**).
5. Measure (D1) to the other end of the axle in the same manner as in **Step 4**.. Record this measurement (**See Figure 4-7**).

6. Set D about 1/8" shorter than D1 to insure proper trailer tracking on slope of road.
7. The suspensions must be in good repair with no binding or other restrictions before aligning. All defective parts of the suspension or axles must be replaced immediately.

b. Spring Suspension Axles

SPRING SUSPENSION TORQUE CHART				
Size	1"	7/8"	7/8" U-bolt	1/2"
Torque in Ft.Lbs.	480-500	250	300	55-60

1. If axle is not in line, cut suspension hangers off one side of undercarriage. Align axle and weld hangers back on.

4-8 ELECTRIC/HYDRAULIC BRAKE SYSTEM MAINTENANCE

⚠ WARNING
USE GREAT CARE IF WHEELS OR BRAKE DRUMS MUST BE HANDLED. THEY MAY BE VERY HOT AND CAN CAUSE SERIOUS INJURY.

4-8.1 General

- a. Check the brake system for loose, missing, deformed, or corroded fastenings. Replace and tighten defective hardware.
- b. Check brake linings for excessive wear or distortion.

4-9 HUB AND DRUM MAINTENANCE

4-9.1 Clean and inspect the brake drums whenever relining the brakes. To be suitable for further service, the brake drum should pass the following checks.

- a. The brake surface should be free of scoring, excessive heat checks and cracks.
- b. The brake surface diameter should be within the maximum diameter cast or stamped on the drum.
- c. The mounting holes and pilot must be round and true.
- d. The mounting surface must be clean and flat.

WARNING

FAILURE TO REPLACE FAULTY BRAKE DRUMS WILL RESULT IN AN UNRELIABLE BRAKING SYSTEM, AND MAY LEAD TO AN ACCIDENT.

4-9.2 It may be necessary to turn or resurface the braking surface to remove small heat checks or other surface defects resulting from normal use.

- a. The maximum diameter cast into the back plate portion of the brake drum is the maximum diameter or discard diameter to which the brake drum may be turned or worn and still be usable. If any portion of the brake surface exceeds the maximum diameter it must be discarded. The maximum is .120 over the nominal new diameter unless stated otherwise on the casting. The maximum diameter cast into the brake drum supersedes all published information.
- b. When resurfacing a drum, allow at least 0.040 inches under the maximum diameter for additional wear.

WARNING

TURNING A BRAKE DRUM BEYOND 0.040 INCHES UNDER THE MAXIMUM DIAMETER WILL RESULT IN A WEAKER BRAKE DRUM AND MAY RESULT IN AN ACCIDENT.

4-9.3 Replacement of the brake drum is required if any of the following conditions exist:

- a. The brake drum is cracked.
- b. The brake surface is heat checked, grooved or worn beyond the rebore limit or the maximum diameter.
- c. The back plate is cracked.
- d. The bolt holes are elongated.
- e. The brake drum has been severely overheated.
- f. The brake drum is out-of-round.

CAUTION

REPLACE BRAKE DRUMS IN PAIRS TO ACHIEVE THE SAME BRAKING POWER ON BOTH WHEELS AND MAINTAIN AN EVEN BRAKING LOAD ON THE AXLE. FAILURE TO DO THIS MAY SIGNIFICANTLY REDUCE THE PERFORMANCE, SERVICE LIFE, AND/OR SAFETY OF YOUR VEHICLE.

4-9.4 Replace the hub and drum as follows (**See Figure 4-8**):

- a. Remove the brake drum (**See Figure 4-8**). It may be necessary to release the slack adjuster.
- b. Remove hub cap and catch lubricant in a pan.
- c. Remove outer spindle nut, spindle locking washer, inner spindle nut, and bearing. Remove hub from axle.
- d. Using an appropriate driver, remove inner bearing cone, and seal.
- e. Using an appropriate driver, remove bearing cups from hub.
- f. Check that the hub cavity is clean. If the hub is to be reused, clean it thoroughly.
- g. Insert bearing cups into the hub.
- h. Clean the mounting surfaces with a good grade commercial cleaner and soft rag. Dry all component parts with a clean, absorbent cloth or paper. Lubricant will not adhere to surfaces wet with solvent.
- i. Install inner bearing, cone, and seal.

IMPORTANT

DO NOT MIX NEW CUPS WITH OLD CONES OR NEW CONES WITH OLD CUPS.

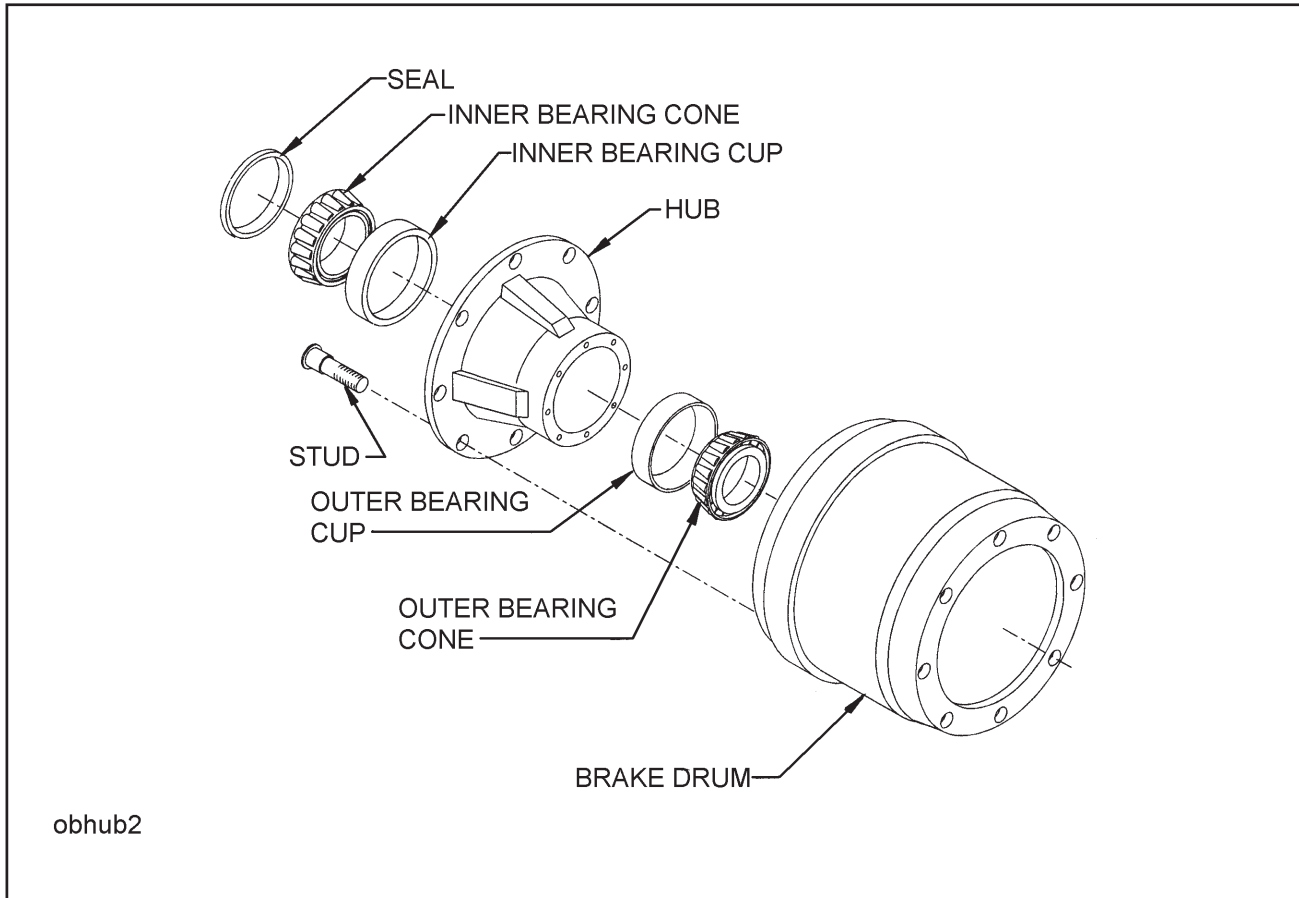

Figure 4-8 Outboard Mount Hub and Drum

- j. Place the hub or wheel over the axle spindle being careful to align the hub bore with the axle. Do not damage the seal. Support the hub assembly until the outer bearing cone and spindle nut are installed, to avoid damaging the seal.
- k. Install the outer bearing cone and inner spindle nut, tightening the nut until it is snug against the outer bearing cone. Remove the hub support allowing the hub to rest on the bearings.
- l. Install and adjust bearings (**See Wheel Bearing Lubrication and Adjustment**).
- m. Install the hub cap with the proper gasket. Tighten the cap screws of the hub cap to 15 to 20 ft-lbs. of torque.
- n. Remove the filler plug and fill the hub cavity to the recommended level with a gear type oil.
- o. Place the drum over the hub and brake shoes being careful not to damage the threads on the studs. Make sure the drum seats flat against the hub flange and mates properly with the hub pilot. There should be no interference between the brake drum pilot chamfer and the corner radius on the hub. If interference exists, the hub will not be able to function properly.

4-10 WHEEL BEARING LUBRICATION AND ADJUSTMENT

With semitrailer sitting level, the oil level must be checked daily and maintained between the "ADD" and "FULL" lines on the hub cap window. Check for cracked windows, missing filler plugs, and oil leaks. Add hub oil through the "POP-IN" filler plug located in the center of the hub windows. Re-install the "POP-IN" plugs after filling each hub. Adjust wheel bearings and change oil every 50,000 miles or with each brake lining replacement, whichever occurs first.

4-10.1 Adjustment

- a. With a drain pan under the hub cap, remove the hub cap assembly allowing oil to drain.
- b. Lift the wheel off of the ground.
- c. Adjust slack adjuster to eliminate brake drag during tire/wheel rotation.
- d. Remove outer lock nut and inner nut and lock washer.
- e. Tighten the inner adjustment nut to a minimum of 75 ft.-lbs., while rotating wheel to insure proper seating of the bearings and cups in the wheel hub.
- f. Loosen the inner adjustment nut so that the wheel will turn freely.
- g. Retighten the inner adjustment nut to 50 ft.-lbs. while rotating the wheel, to properly position the bearings for the final adjustment.
- h. Loosen the inner adjustment nut 1/3 turn.
- i. Install the spindle nut lock washer so that the dowel on the inner nut will align with a hole in the lock washer and the washer tang fits in the spindle keyway.
- j. Install the outer lock nut and tighten to 250-300 ft.-lbs. End-play of .001" to .010" must be present in the adjusted wheel bearing assembly.
- k. Install the hub cap with a new gasket and fill with oil to the full mark. Use 90 weight gear oil.
- l. Adjust brakes according to **Section 4-8.4 a.**
- m. Check hub oil level after the wheel has set level in one position for a few minutes to allow the oil to work into the bearings.

DANGER

FAILURE TO TORQUE THE OUTER LOCK NUT PROPERLY COULD CAUSE THE WHEEL TO COME OFF DURING VEHICLE OPERATION RESULTING IN PROPERTY DAMAGE OR LOSS OF LIFE.

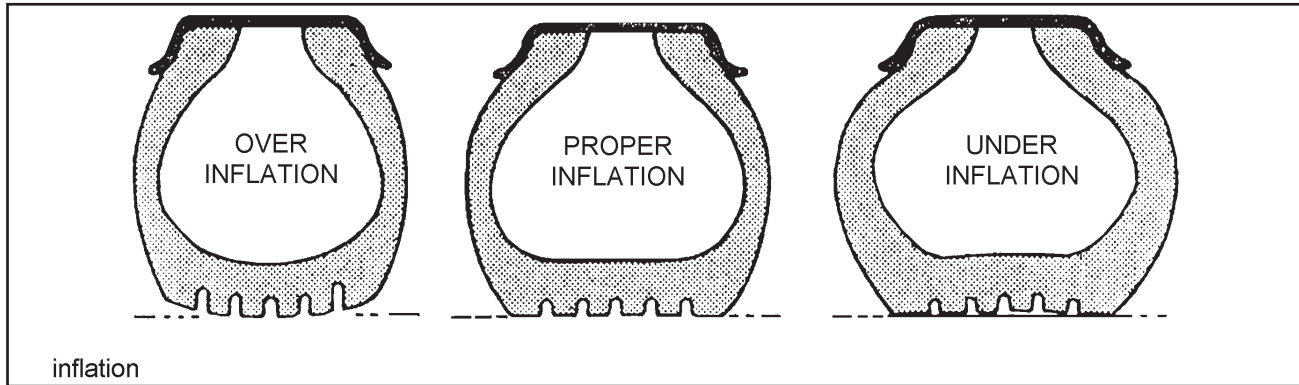

Fig. 4-9 Tire Inflation Examples

4-11 TIRE MAINTENANCE

4-11.1 Tire Inflation. Tire inflation will cause tire to ground contact characteristics as shown in **Figure 4-9**. Tire inflation should be checked daily while the tire is cold, and during road stops. Checking the tire pressures while tires are hot will give a faulty increased pressure reading. Adjusting tire air pressure to the specified amount while tires are hot will produce improper tire to road contact and thus abnormal wear. Do not exceed cold inflation pressure listed on the semitrailer VIN plate located on the front of the semitrailer. Exceeding cold inflation pressure will result in damaged tire bodies, rims, and wheels. Replace all valve stem caps when pressure checking/adjusting has been completed. Remove any foreign objects from between duals.

4-11.2 Tire Matching. Both tires on the same spindle must be the same size in order to properly distribute the load and braking forces between them. The tire must be mounted on a rim and properly inflated before measuring. If there is an allowable difference in size the smaller tire should be mounted to the inside position of the duals.

- a. **Tape Measuring Method:** Measure around each tire on the tread surface. A maximum difference of 3/4" is allowed between the two mating tires of a dual (**See Figure 4-10**).
- b. **Straight Edge or String Method:** (This method can not be used if tire and wheel assemblies are not mounted on the axle.) Jack semitrailer up until the wheels are off of the ground. Hold a straight edge against the tires of both ends of an axle. A gap at one tire indicates a smaller tire. A maximum of 1/8" gap is allowed (**See Figure 4-11**).

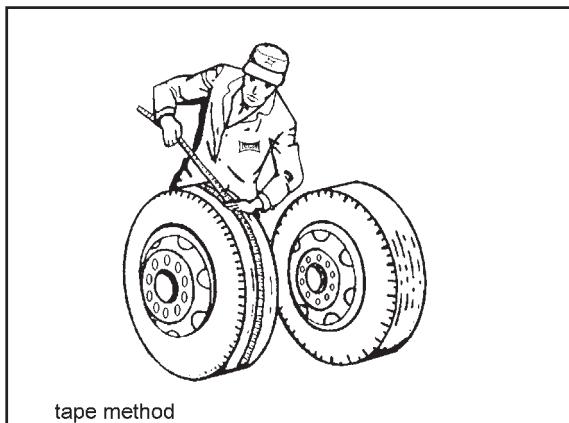

tape method

Fig. 4-10 Measuring Tape Method

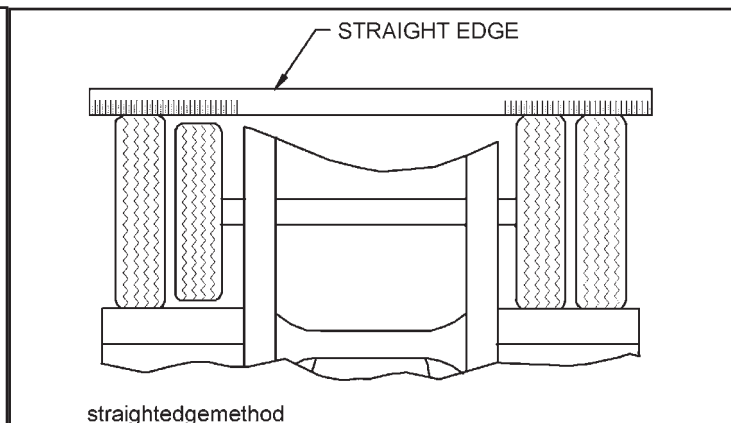

straightedgemethod

Fig. 4-11 Straight Edge Method

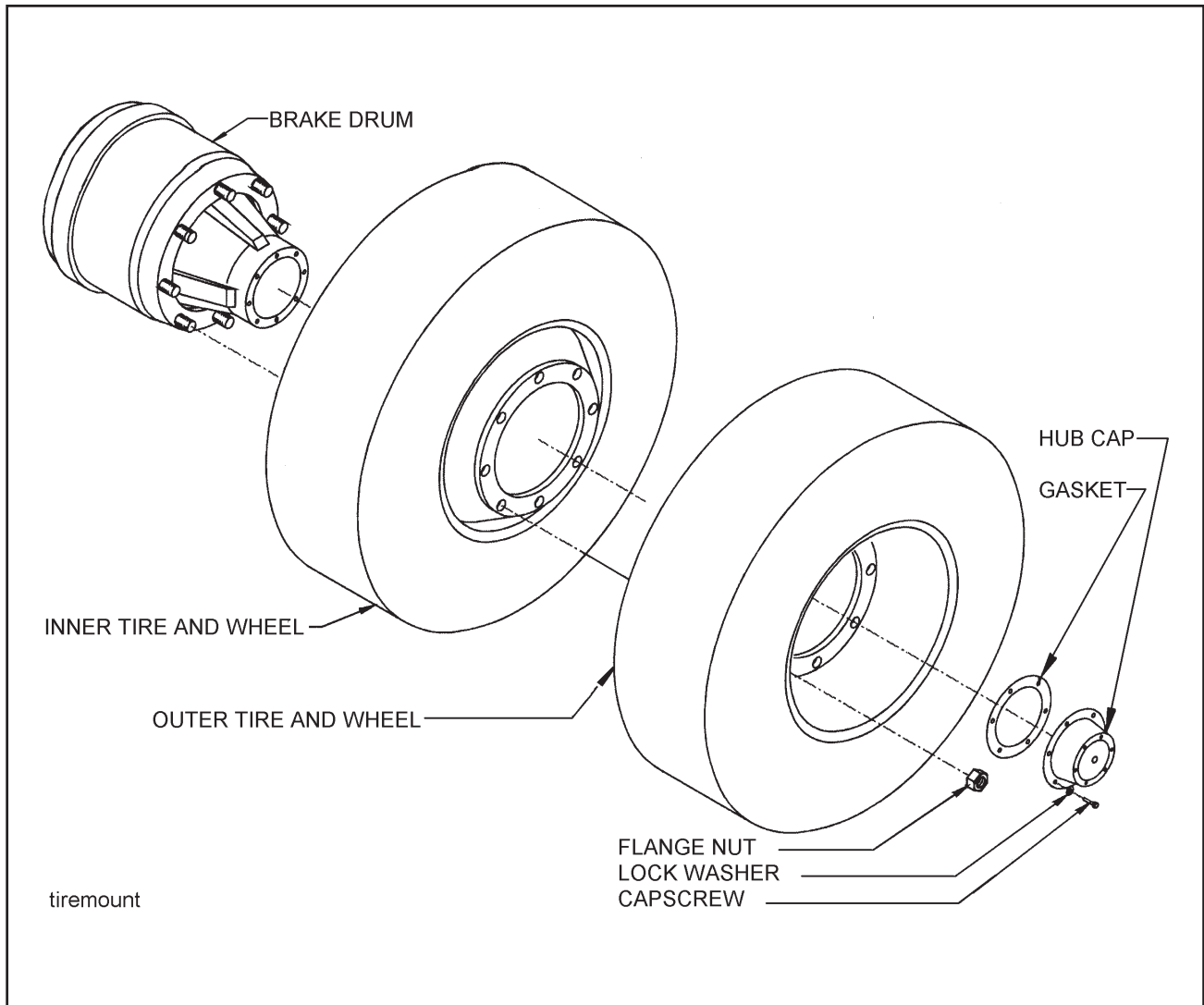

Figure 4-12 Mounting Tires and Wheels

4-11.3 Mounting Tire and Wheel

- a. Make sure that all mounting surfaces are clean and free of rust, dirt or paint. A wire brush may be used to clean these surfaces (See Figure 4-12).
- b. Position the inner disc wheel over the studs, being careful not to damage the stud threads. Make sure that the disc wheel is flat against the mounting surface and that there is clearance between the disc wheel taper and brake drum.
- c. Install the inner capnuts on the studs and tighten to fifty foot-pounds using the sequence illustrated in Figure 4-13. Make certain that the left-handed threads are installed on the driver side of the vehicle and the right-handed threads are installed on the curbside of the vehicle.
- d. Tighten the inner capnuts to full torque of 450 to 500 foot-pounds using the sequence shown in Figure 4-13.
- e. Position the outer disc wheel over the capnuts being careful not to damage the inner capnut threads. Be sure the valve stems for both the inner and outer tire are accessible.

- f. Install the outer capnuts and tighten to 50 foot-pounds using the sequence in **Figure 4-13**. Then tighten to full torque of 450 to 500 foot-pounds using the same sequence.
- g. Torque will drop after the first 50 to 100 miles of operation. Check the capnuts for proper torque after this interval and retighten them. Loosen the outer capnuts and retighten the inner and outer capnuts per **steps d. to f.**

⚠ WARNING

USE A TORQUE WRENCH TO ASSURE PROPER TORQUE. INSUFFICIENT TORQUE CAN CAUSE STUD BREAKAGE AND DAMAGE WHEEL PILOTS. OVERTORQUE CAN OVERSTRESS THE STUDS AND STRIP THE THREADS.

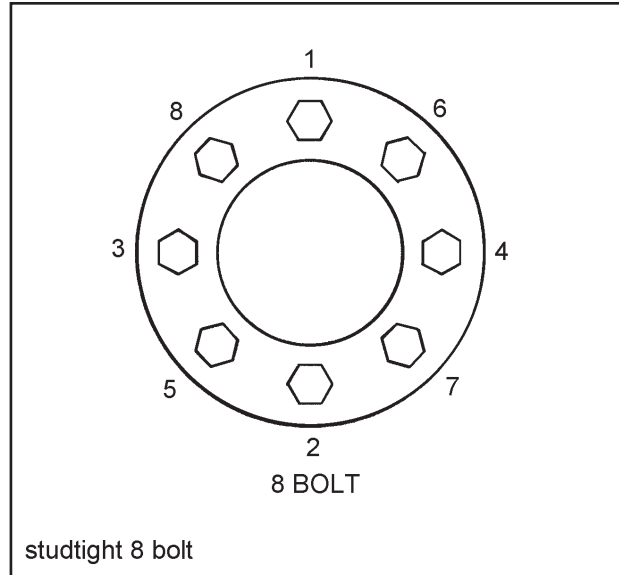

Figure 4-13 Stud Tightening Sequence

4-12 HYDRAULIC ENGINE PACKAGE

The hydraulic engine package should be inspected weekly to insure continued proper operation. The inspection should include:

- 4-12.1** Check the hydraulic oil level weekly, or after any leakage. See **Table 4-1** for proper hydraulic oil. With all hydraulic cylinders in the retracted position and with the engine stopped, check the hydraulic oil level.
- 4-12.2** Check hoses weekly for cracks or leaks. If a valve or line leaks, it should be replaced immediately.

- 4-12.3** Check the engine oil each time before using. Oil level should be maintained between the "ADD" and "FULL" marks on the oil dip stick. For further maintenance procedures and proper lubrication specifications, please refer to the engine owner's manual that was supplied with the hydraulic engine package.
- 4-12.4** Replace hydraulic filter with new filter at least every 6 months or more often under adverse conditions.
- 4-12.5** Use the fuel recommended for the engine package installed on you trailer.

Troubleshooting should be performed by a trained technician. Landoll Corporation is not responsible for equipment that is improperly maintained. Contact an authorized Landoll Service center for servicing.

5-1 ELECTRICAL

Most electrical system problems show up as a burned out light or fuse, or inoperative electrical component. Wiring, grounds, or components may be at fault. Locate the symptom in this section that best identifies your electrical problem. Check out each possible problem under that symptom. If the problem cannot be located, see an automotive electrical specialist. For maintenance procedures, see **Section 4-5**.

SYMPTOM

PROBLEM: REMEDY

NO LIGHTS

Fuse blown: replace fuse.

Connection at plug-in: tighten connection.

Broken or corroded wires: replace wire.

Ground wire loose: clean and tighten ground.

Dirty or corroded 7-way connector or receptacle: Clean w/ wire brush or replace connector or receptacle.

LIGHTS FLICKERING

Wires shorted or loose: locate, insulate, replace, or tighten.

LIGHTS DIM

Voltage difference between trailer & tractor: tractor supply wire or circuit components are too low a capacity. - Enlarge wire or component. Match bulbs with tractor voltage.

LIGHTS BRIGHT & BURN OUT

Ground wire disconnected: connect ground wire.

Voltage difference between trailer & tractor: tractor supply wire or circuit components are too low a capacity. - Enlarge wire or component. Match bulbs with tractor voltage.

FUSE BLOW-OUT OR CIRCUIT BREAKER TRIPPING

Vibration: locate source of vibration and repair.

Short circuit: replace fuse and try all accessories. If fuse blows right away, locate short and repair.

LAMP BULB BURN OUT

Vibration: locate source of vibration and repair.

Short circuit: replace fuse and try all accessories. If fuse blows right away, locate short and repair.

Loose connection: check lamp sockets and ground connections.

Intermittent short: locate short and repair.

Improper voltage: check voltage regulator output.

5-2 TIRES - WHEELS - SUSPENSION

Most tire, wheel, and suspension related problems are due to excessive loads, extreme conditions, and improper maintenance. Tire, wheel, and suspension problems can be easily detected and solved by checking the following guide. For maintenance procedures, see **Sections 4-6, 4-9, 4-10, and 4-11.**

SYMPTOM

VIBRATIONS WHILE DRIVING

PROBLEM: REMEDY

Improper tire inflation: inflate to proper pressure.

Tires cupped or have flat spots: replace tires.

Wheels bent or loose: replace or tighten.

Tires incorrectly mounted: remount.

Mud in wheels: clean wheels.

Tire(s) out of balance: balance tires.

Brakes dragging: locate cause and repair.

Object(s) stuck between duals: remove object(s).

RAPID TIRE WEAR/DETERIORATION:

CENTER TREAD WEAR

Over inflation: deflate to correct inflation.

SHOULDER TREAD WEAR - BOTH SHOULDERS

Under inflation: increase inflation to correct PSI. Check axle alignment.

Overloading: loads are above rated tire capacity. DO NOT load above rated tire capacity.

SHOULDER TREAD WEAR - ONE SHOULDER

Axle damage: straighten or replace axle.

OVERALL TREAD WEAR

Overloading: check tire load rating.

High speeds: adjust speed according to road and load conditions.

Incorrect dual matching: properly match dual tires.

TIRE FLAT SPOTS

Quick stops: adjust braking practices.

Grabbing brakes: adjust brakes properly.

Worn or loose wheel bearings: adjust or replace as needed.

Out of balance wheels and tire: balance wheels and tires.

UNEVEN WEAR

Suspension bushings worn: replace bushings.

Worn or loose wheel bearings: adjust or replace as needed.

Out of balance wheels and tires: balance wheels and tires.

RIM FAILURE*:

CRACKING

Overinflated tires: deflate tire to proper PSI.

High speeds: adjust speed according to road and load conditions.

High speed cornering: adjust cornering practices.

Overloading: check rim load rating.

***IN ALL INSTANCES OF RIM FAILURE, REPLACE THE RIM IMMEDIATELY!**

TIRES - WHEELS - SUSPENSION (CONTINUED)

SYMPTOMS

PROBLEM: REMEDY

BENDING OR WARPING

Curb-hopping or potholes: adjust turning practices and adjust speed accordingly with road conditions.

Improper tightening sequence: follow proper tightening sequence. (See Figure 4-13.)

BROKEN STUDS*

Over tightening: use correct torque when mounting.

Under torque: Use correct torque and tightening sequence when mounting.

Rim not seated: Adjust rim to equal distance with hub.

***REPLACE BROKEN STUDS BEFORE USING THE SEMITRAILER!**

SEMITRAILER TRACKING PROBLEMS:

TRACKS TO ONE SIDE

Axle alignment: re-align axle.

TRACKS TO EITHER SIDE

Broken or bent springs or equalizers: replace defective parts.

5-3 ELECTRIC/HYDRAULIC BRAKE AND BRAKE DRUM

For maintenance procedures, see Sections 4-8.

SYMPTOM

PROBLEM: REMEDY

NOISY BRAKES

Underadjustment: adjust.

Lack of Lubrication: lubricate.

Broken Brake Components: replace components.

Incorrect Brake Components: correct.

LOCKING BRAKES

Loose, Bent, or Broken Brake Components: replace components.

Underadjustment: adjust.

Out-of-Round Drums: machine or replace.

PULLS TO ONE SIDE

Incorrect Tire Pressure: inflate evenly on both sides to req. pressures.

Unmatched Tires on Same Axle: match tires on axle.

Restricted Brake Lines or Hoses: repair or replace.

Malfunctioning Cylinder Assembly: check for stuck or sluggish pistons.

Defective or Damaged Shoe and Lining: install new shoe and lining - complete axle.

One Side Out-of-Adjustment: adjust.

DRAGGING

Improper Fluid: replace rubber parts, fill with DOT4 fluid.

Blocked Master Cylinder: open with compressed air or replace cylinder.

Improper Lining Thickness or Location: install new shoes and linings.

ELECTRIC/HYDRAULIC BRAKE AND BRAKE DRUM (CONTINUED)

SYMPTOM

PROBLEM: REMEDY

NO BRAKES

Broken or Kinked Brake Line: repair or replace.
Severe Underadjustment: adjust brakes.
Malfunctioning Actuation System: See Section 5-4.

WEAK BRAKES

Brake Adjustment Not Correct: manual adjust brakes automatic make several reverse stops.
Excessively Worn Brake Linings: replace shoe and lining.
Incorrect Lining: install correct shoe and lining.
Grease or Fluid Soaked Lining: repair grease seal or wheel cylinder, install new shoe and lining.
Frozen Master Cylinder or Wheel Cylinder Pistons: recondition or replace all cylinders, brake fluid.
Glazed Lining: reburnish or replace.
Excessive Drum Wear: replace.
Trapped Air in Lines: bleed system.
Overloaded Trailer: Correct.
Malfunctioning Actuating System: See Section 5-4.

HARSH BRAKES

Brakes Adjustment Not Correct: manual adjust brakes, See Section 5-4.
Grease or Fluid on Linings: replace shoes and linings.

SURGING BRAKES

Grease or Oil on Linings: clean or replace.
Out of Round Drums or Cracked Drums: machine or replace.

5-4 TROUBLESHOOTING BRAKE SYSTEM

5-4.1 Attach trailer to towing vehicle, but do not connect 7-way connector from truck to trailer.

5-4.2 Pull the break-a-way switch. The electrical/hydraulic unit should run. Do not run unit for more than 2 minutes or it will get hot and damage unit. If the unit does not run, check battery condition and system wiring. Reset the break-a-way switch which will turn the unit off.

Note: When the unit is running the motor will generate a “hum” that changes pitch as the unit builds pressure.

5-4.3 Connect 7-way connector from truck to trailer. Turn the ignition switch on and check the in-cab electronic brake controller to make sure green light is on. The electric/hydraulic unit should run whenever the brake pedal is depressed. The electric/hydraulic unit should pressurize when electronic manual slide knob is slid over to apply brakes.

5-4.4 If the electric/hydraulic unit is not working correctly, then follow test for electric/hydraulic brake actuators (See Section 5-5).

CAUTION

TESTING THE ELECTRICAL/HYDRAULIC UNIT CONFIRMS THAT IT IS OPERATING. IT DOES NOT CONFIRM THAT THE BRAKES ARE OPERATING PROPERLY. REGULAR INSPECTION, ADJUSTMENT, AND MAINTENANCE OF THE BRAKES, LINES, HOSES, DRUMS, DISCS, FLUID, AND OTHER ASSOCIATED COMPONENTS IS NECESSARY TO ENSURE PROPER BRAKE OPERATION.

5-5 TEST FOR ELECTRIC/HYDRAULIC BRAKE ACTUATORS

The purpose of this section is to determine whether or not the unit needs to be repaired, or if there is another cause for the malfunction.

THIS TEST IS IMPORTANT FOR THE FOLLOWING REASONS:

- The vast majority of the units returned actually work as intended and meet all specifications.
- Improper wiring, low voltage, and poor wire connections are the main cause of failure.
- Using the electric/hydraulic unit under low voltage conditions will void the warranty.

WARNING

MAKE SURE THE BRAKE LINE IS CONNECTED TO THE ELECTRICAL/HYDRAULIC UNIT OR TAKE MEASURES TO AVOID BRAKE FLUID FROM SPRAYING PEOPLE OR PROPERTY WHEN CONDUCTING THESE TESTS. DO NOT USE A BATTERY CHARGER OR TEST STAND POWERED BY A BATTERY CHARGER. THIS COULD DAMAGE THE UNIT OR SHOW FALSE INDICATIONS DURING TESTING.

ITEMS REQUIRED FOR THIS TEST

- Fully charged 12 volt battery
- Extra wire for jumpers to battery if electrical/hydraulic unit wires have been cut and are too short
- Volt meter

IMPORTANT

BEFORE YOU BEGIN, CHECK FOR PROPER VOLTAGE AT THE ELECTRICAL/HYDRAULIC UNIT. WITH A VOLT METER, ATTACH NEGATIVE (-) END TO WHITE WIRE AND POSITIVE (+) END TO BLACK WIRE. APPLY BRAKES. VOLTAGE SHOULD BE AT LEAST 9 VOLTS. OPERATION BELOW THIS VOLTAGE COULD DAMAGE THE UNIT AND VOID THE WARRANTY. IF THE VOLTAGE IS GREATER THAN 14 VOLTS, THE UNIT NEEDS TO BE REPAIRED.

5-5.1 PRELIMINARY TEST PROCEDURE

- a. Disconnect all spliced wires connected to the wires coming out of the electrical/hydraulic unit leaving only the blue, black, white, and blue/white striped wires.
- b. It is important that the unit is disconnected from any other wires going to the towing vehicle or break-a-way switch and break-a-way battery. Failure to do so may result in a faulty test.

5-5.2 TESTING FOR PROPER OPERATION OF THE CIRCUIT BOARD

- a. Use a 12 volt battery
- b. Connect the white wire to the negative (-) terminal of the battery.
- c. Connect the black wire to the positive (+) terminal of the battery.
- d. The motor **should not** run.
- e. If the motor runs, the unit needs repaired.

5-5.3 TESTING MOTOR, PRESSURE VALVE AND CIRCUIT BOARD

- a. Leave the white wire connected to the negative (-) terminal of the battery.
- b. Connect the solid blue and solid black wires together to the positive (+) terminal of the battery.
- c. The motor should run and the unit should pressurize.
- d. If the motor does not run, the unit needs repaired. If the motor runs, but will not build up pressure, the problem most likely is a defective solenoid valve in the electrical/hydraulic unit and needs repaired.

5-5.4 TESTING BREAK-A-WAY CIRCUIT

- a. Leave the solid white wire connected to the negative (-) terminal of the battery.
- b. Connect only the blue and white striped wire to the positive (+) terminal of the battery.
- c. The motor should run and the unit should pressurize.
- d. If this does not occur, the unit needs repaired.

5-5.5 TESTING FOR FAULTY WIRING, ELECTRICAL CONNECTIONS, AND IMPROPER ELECTRONIC BRAKE CONTROLLER

- a. If the electric/hydraulic unit checks out o.k., reconnect the wires leading to the trailer plug and repeat **Sections 5-5.2 thru 5-5.4**.
- b. If you do not get the same results as before, the problem is in the trailer wiring or the electronic brake controller.

5-5.6 MALFUNCTION COMPLAINTS AND CAUSES

“CLICKING” SOUND COMES FROM ELECTRICAL/HYDRAULIC UNIT

Some brake controllers are not compatible with each other and will cause the unit to “click” repeatedly. Do not use the Tekonsha “Sentinel” (9055) or “Prodigy” (90185). Acceptable controllers include the Carlisle “HSC”, Tekonsha “Voyager” (9030) and (9035), Envoy (9040), Dexter “Predator”, and Draw-Tite “Activator II and III”

ELECTRONIC BRAKE CONTROLLER INDICATES AN “OVERLOAD”

Make sure the blue/white striped wire is not making contact with the solid wire circuit of the electrical/hydraulic unit.

UNIT RUNS CONSTANTLY

Low voltage to the electrical/hydraulic unit from the towing vehicle.
Bad break-a-way battery circuit or bad break-a-way switch.
Bad solenoid valve or connection in the electrical/hydraulic unit.

BRAKES TAKE OVER 2 SECONDS TO COME ON

Improper bleeding or brake shoes not adjusted.
Low voltage from towing vehicle. Make sure unit is getting a minimum of 9.0 volts DC when brakes are applied and the in-cab controller set at maximum.

5-6 TROUBLESHOOTING IN-CAB ELECTRONIC BRAKE CONTROLLER

For installation and adjustment of electronic brake controller, see **Section 3-19**.

TOW VEHICLE CONNECTED TO TRAILER, NO GREEN LIGHT

Corrosion on trailer plug contact

Loose POWER or GROUND connection

TOW VEHICLE CONNECTED TO TRAILER, LIGHT IS GREEN. WHEN MANUAL SLIDE KNOB IS ACTIVATED:

AND NO RED LIGHT.

POWER set at or near minimum.

Short on BRAKE line (BLUE wire)

BLACK AND WHITE wires reversed, control destroyed

12 volts from external source on BRAKE line (BLUE wire)

LIGHT IS DIM RED OR FLASHING RED

Open on GROUND line (WHITE wire)

Short on BRAKE line (BLUE wire)

LIGHT GLOWS DIM RED AND GETS BRIGHTER AS POWER KNOW IS DECREASED.

Short on BRAKE line (BLUE wire)

Defective brake unit

BRAKING WITH FOOT PEDAL IS TOO AGGRESSIVE

Sensor set too aggressive, see LEVELING SENSOR

Power set too high

TOW VEHICLE CONNECTED TO TRAILER, BRAKE PEDAL DE-PRESSED:

NO RED LIGHT

Vehicle not moving, need to be moving for brakes to apply

No signal from brake light, test voltage on RED wire

Sensor set improperly, see LEVELING SENSOR

Bad connection on RED wire

Blown stoplight fuse

5-7 HYDRAULIC SYSTEM

Most hydraulic system failures follow the same pattern: a gradual or sudden loss of pressure or flow with a resulting loss of cylinder or motor power. Any one of the system's components may be at fault. By following step-by-step procedures, the trouble can be located in a short time.

SYMPTOM

SEMITRAILER LOCKED IN
TILTED POSITION

PROBLEM: REMEDY

Restrictor valve plugged: raise the trailer slightly (to move particle away from orifice in valve attached to tilt cylinders), then lower the trailer slowly. Properly support trailer and hitch before disconnecting hydraulic lines to find obstruction.

SYSTEM INOPERATIVE

Not enough oil in system: fill, check for leaks.

Wrong oil in system: change oil, see specifications.

Filter dirty or clogged: drain oil and replace filter.

Hydraulic lines dirty or collapsed: clean or replace as necessary.

Air leaks in pump suction line: repair or replace as necessary.

Worn or dirty pump: clean, repair or replace. Check for contaminated oil. Drain and flush.

Badly worn components: examine for internal leakage. Replace faulty components. Check for cause of wear.

Leakage: check all components, and relief valve for proper settings.

Excessive load: check unit specifications for load limits.

Slipping or broken pump drive: repair or replace couplings. Check for alignment.

SYSTEM OPERATES ERRATICALLY

Air in the system: check suction side of system for leaks. Repair leaks.

Cold oil: allow ample warm-up time. Use proper weight oil for operating temperature.

Dirty or damaged components: clean or repair as needed.

Restriction in filters or lines: clean and/or replace filter or lines.

Not enough oil in system: fill and check for leaks.

SYSTEM OPERATES SLOWLY

Oil viscosity too high, or "cold oil": Allow oil to warm up before operating.

Low pump drive speed: increase engine speed (check pump owners manual for specifications).

Low oil level: check reservoir and add oil as necessary.

Air in system: check suction side for leaks. Repair leaks.

Badly worn pump, valves, cylinders, etc.: repair or replace faulty component(s) as necessary.

Restrictions in lines or filter: clean and/or replace filter or lines.

Improper adjustments: check orifices, relief valves, etc. Adjust as necessary.

Oil leaks: tighten fittings. Replace seals, gaskets and damaged lines.

SYSTEM OPERATES TOO FAST

Engine running too fast: reduce engine speed.
See Landoll Dealer.

HYDRAULIC SYSTEM (CONTINUED)

SYMPTOM

PROBLEM: REMEDY

OVER HEATING OF
OIL IN SYSTEM

Incorrect, low, dirty oil: use recommended oil. Fill reservoir with clean oil. Replace filter.

Engine running too fast: reduce engine speed.

Excessive component internal leakage: repair or replace component as necessary.

Restriction in filters or lines: clean and/or replace filter or lines.

Insufficient heat radiation: clean dirt and mud from reservoir and components.

Malfunctioning component: repair or replace.

FOAMING OF OIL

Incorrect, low, or dirty oil: replace, clean or add oil as needed.

Water in oil: replace oil

Air leaks: check suction line and component seals for suction leaks. Replace defective parts.

NOISY PUMP

Low, incorrect, foamy oil: replace, clean, or add oil as needed.

Suction line plugged: clean out obstruction or replace line. Flush system, replace filter.

Pump damaged: repair or place.

LEAKY PUMP

Damaged or worn shaft seal: Replace seal and/or shaft and check for misalignment.

Loose or broken parts: Tighten or replace.

CYLINDERS MOVE WITH
CONTROL VALVE IN
NEUTRAL POSITION

Leaking cylinder seals or fittings: Replace worn seals or fittings.

Control valve not centering when released: Check linkage for binding and repair.

Valve damaged: Repair or replace.

CONTROL VALVE LEAKS

Seals damaged or worn: Replace.

CYLINDER LEAKS

Seals worn or damaged: Replace.

Rod damaged: Replace.

Barrel damaged: Replace.

CYLINDERS DO NOT FUNCTION,
OR CREEP WITH PTO
DISENGAGED

Leaking fittings or cylinder seals: Tighten loose fittings. Replace worn seals or fittings.

5-8 HYDRAULIC POWER SUPPLY ENGINE PACKAGE

To troubleshoot the engine in the hydraulic engine package, please refer to the owners manual that was provided with the engine package.

NOTES:
