

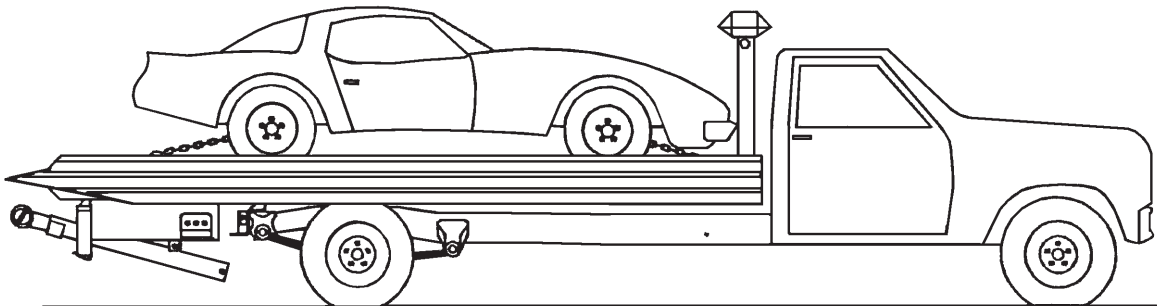

**TWO TON
LOADOLL
OPERATOR'S MANUAL**



**1900 North Street
Marysville, KS 66508
(785)562-5381**

TWO TON LOADOLL OPERATOR'S MANUAL

PURCHASED FROM: _____ DATE ____ / ____ / ____

ADDRESS: _____

PHONE NO.: _____ SERIAL NO.: _____

REPORTING SAFETY DEFECTS

If you believe that your vehicle has a defect which could cause a crash or could cause injury or death, you should immediately inform the National Highway Traffic Safety Administration (NHTSA) in addition to notifying Landoll Manufacturing.

If NHTSA receives similar complaints, it may open an investigation, and if it finds that a safety defect exists in a group of vehicles, it may order a recall and remedy campaign. However, NHTSA cannot become involved in individual problems between you, your dealer, or Landoll Manufacturing.

To contact NHTSA, you may either call the Auto Safety Hotline toll-free at 1-800-424-9393 (or 366-0123 in Washington, D.C. area) or write to: NHTSA, U.S. Department of Transportation, Washington, D.C. 20590. You can also obtain other information about motor vehicle safety from the Hotline.

In the event of a defect or problem with your LANDOLL equipment, please notify LANDOLL CORPORATION:

**LANDOLL CORPORATION
SALES AND SERVICE
1900 NORTH STREET
MARYSVILLE, KANSAS 66508**

OR PHONE:

1-800-HAULLOLL

(1-800-428-5655)

FAX NO.: (785)562-3240

FOR REPLACEMENT PARTS:

(785)562-4650

1-800-423-4320

FAX NO.: (785) 562-4654

TABLE OF CONTENTS

SECTION NO.	DESCRIPTION	PAGE NO.
1	INTRODUCTION	1-1
2	STANDARD SPECIFICATIONS.	2-1
3	OPERATING INSTRUCTIONS.	3-1
3-1	BED TILT CONTROL	3-1
3-2	BED SLIDE CONTROL	3-3
3-3	WINCH CONTROLS.	3-3
3-4	BASIC WHEELIFT CONTROLS (OPTION)	3-5
3-5	SPECIAL WHEELIFT CONTROL (OPTION)	3-5
3-6	POWER TAKE-OFF (PTO)	3-6
3-7	BED LOADING	3-6
3-8	BED UNLOADING	3-8
3-9	LOAD PLACEMENT.	3-9
3-10	SECURING LOADS TO BED	3-9
3-11	WHEELIFT OPERATION (OPTION)	3-10
3-12	COLD WEATHER OPERATION	3-13
3-13	HOT WEATHER OPERATION	3-13
4	MAINTENANCE AND LUBRICATION	4-1
4-1	MAINTENANCE SCHEDULE	4-4
4-2	MAINTENANCE PROCEDURES.	4-4
4-3	FRAME AND DECK.	4-5
4-4	HYDRAULIC SYSTEM	4-5
4-5	ELECTRICAL SYSTEM	4-6
5	TROUBLESHOOTING GUIDE.	5-1

SAFETY PRECAUTIONS



THIS IS THE SAFETY ALERT SYMBOL. IT IS USED TO ALERT YOU TO POTENTIAL INJURY HAZARDS. OBEY ALL SAFETY MESSAGES THAT FOLLOW THIS SYMBOL TO AVOID POSSIBLE INJURY OR DEATH.

DANGER

DANGER INDICATES AN IMMEDIATELY HAZARDOUS SITUATION WHICH, IF NOT AVOIDED, WILL RESULT IN DEATH OR SERIOUS INJURY.

WARNING

WARNING INDICATES A POTENTIALLY HAZARDOUS SITUATION WHICH, IF NOT AVOIDED, COULD RESULT IN DEATH OR SERIOUS INJURY.

CAUTION

CAUTION INDICATES A POTENTIALLY HAZARDOUS SITUATION WHICH, IF NOT AVOIDED, MAY RESULT IN MINOR OR MODERATE INJURY.

CAUTION

CAUTION USED WITHOUT THE SAFETY ALERT SYMBOL INDICATES A POTENTIALLY HAZARDOUS SITUATION WHICH, IF NOT AVOIDED, MAY RESULT IN PROPERTY DAMAGE.

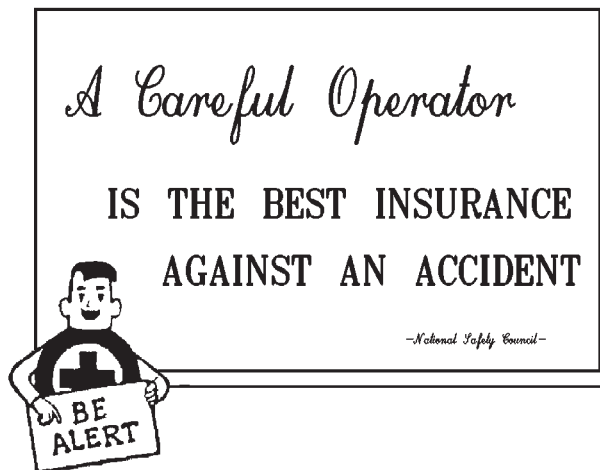

This manual provides operating, servicing, and maintenance instructions, with detailed parts lists for the Two Ton Loadoll, manufactured by Landoll Corporation, Marysville, Kansas 66508.

- SECTION 1** gives basic instructions on the use of this manual.
- SECTION 2** gives specifications for the carrier, including measurements and component specifications. A Standard Bolt Torque Table is provided to give guidelines for bolt torques to be used when servicing this product.
- SECTION 3** gives instructions for the proper operation of the equipment.
- SECTION 4** gives general maintenance procedures, a maintenance schedule, and a lubrication schedule. Improper maintenance will void your warranty.

IF YOU HAVE ANY QUESTIONS CONTACT:

**LANDOLL CORPORATION
1900 NORTH STREET
MARYSVILLE, KANSAS 66508
or phone:
(785) 562-5381 or
(800) 428-5655
or FAX:
(785) 562-4893**

- SECTION 5** is a troubleshooting guide to aid in diagnosing and solving problems with the Loadoll.
- PARTS LIST** is a separate manual showing the various assemblies, subassemblies, and systems. Refer to that manual when ordering Landoll replacement parts. Order parts from your Landoll dealer.
- WARRANTY** The Warranty Registration form is located with the product documents. Fill it out and mail it within 15 days of purchase. The Warranty is printed inside the front cover.

NOTE: IMPROPER ASSEMBLY, MODIFICATION, OR MAINTENANCE OF YOUR LANDOLL MACHINE CAN VOID YOUR WARRANTY.

- COMMENTS** Address comments or questions regarding this publication to:

**LANDOLL CORPORATION
1900 NORTH STREET
MARYSVILLE, KANSAS 66508
ATTENTION: PUBLISHING -DEPT. 55**

STANDARD SPECIFICATIONS

BED LENGTH	19.5' OR 22'
DECK MATERIAL	ALUMINUM OR STEEL
LOAD ANGLE	VARIES FROM 11° TO 14° DEPENDING ON TRUCK
STANDARD BED WIDTH	102"
OPTIONAL BED WIDTH	96"
BED CAPACITY	10,000#
WHEELIFT OPTION CAPACITY	3,000#
WINCH, WORM GEAR CAPACITY	9,000#
HYDRAULIC RESERVOIR CAPACITY	6 GAL.
HYDRAULIC SYSTEM (reservoir, components, and plumbing)	14 GAL.
WEIGHT (kit only, std. bed width, add chassis weight for total, wheelift not included)	
CL19A	3,900 LBS.
CL22A	4,100 LBS.
CL19S	5,900 LBS.
CL22S	6,200 LBS.
WHEELIFT WEIGHT	900 LBS.

**LANDOLL CORPORATION
GENERAL TORQUE SPECIFICATIONS (REV. 4/97)**

THIS CHART PROVIDES TIGHTENING TORQUES FOR GENERAL PURPOSE APPLICATIONS WHEN SPECIAL TORQUES ARE NOT SPECIFIED ON PROCESS OR DRAWING.
 ASSEMBLY TORQUES APPLY TO PLATED NUTS AND CAPSCREWS ASSEMBLED WITHOUT SUPPLEMENTAL LUBRICATION (AS RECEIVED CONDITION). THEY DO NOT APPLY IF SPECIAL GRAPHITE MOLY-DISULFIDE OR OTHER EXTREME PRESSURE LUBRICANTS ARE USED.
 WHEN FASTENERS ARE DRY (SOLVENT CLEANED), ADD 33% TO AS RECEIVED CONDITION TORQUE.
 BOLT HEAD IDENTIFICATION MARKS INDICATE GRADE AND MAY VARY FROM MANUFACTURER TO MANUFACTURER.
 THICK NUTS MUST BE USED ON GRADE 8 CAPSCREWS.
 USE VALUE IN [] IF USING PREVAILING TORQUE NUTS.
TORQUE IS SPECIFIED IN FOOT POUNDS

UNC Size	SAE Grade 2		SAE Grade 5		SAE Grade 8		UNF Size	SAE Grade 2		SAE Grade 5		SAE Grade 8	
1/4-20	4	[5]	6	[7]	9	[11]	1/4-28	5	[6]	7	[9]	10	[12]
5/16-18	8	[10]	13	[16]	18	[22]	5/16-24	9	[11]	14	[17]	20	[25]
3/8-16	15	[19]	23	[29]	35	[43]	3/8-24	17	[21]	25	[31]	35	[44]
7/16-14	24	[30]	35	[43]	55	[62]	7/16-20	27	[34]	40	[50]	60	[75]
1/2-13	35	[43]	55	[62]	80	[100]	1/2-20	40	[50]	65	[81]	90	[112]
9/16-12	55	[62]	80	[100]	110	[137]	9/16-18	60	[75]	90	[112]	130	[162]
5/8-11	75	[94]	110	[137]	170	[212]	5/8-18	85	[106]	130	[162]	180	[225]
3/4-10	130	[162]	200	[250]	280	[350]	3/4-16	150	[188]	220	[275]	320	[400]
7/8-9	125	[156]	320	[400]	460	[575]	7/8-14	140	[175]	360	[450]	500	[625]
1-8	190	[237]	408	[506]	680	[850]	1-14	210	[263]	540	[675]	760	[950]
1-1/8-7	270	[337]	600	[750]	960	[1200]	1-1/8-12	300	[375]	660	[825]	1080	[1350]
1-1/4-7	380	[475]	840	[1050]	1426	[1782]	1-1/4-12	420	[525]	920	[1150]	1500	[1875]
1-3/8-6	490	[612]	110	[1375]	1780	[2225]	1-3/8-12	560	[700]	1260	[1575]	2010	[2512]
1/1-2-6	650	[812]	1460	[1825]	2360	[2950]	1/1-2-12	730	[912]	1640	[2050]	2660	[3325]

METRIC

COARSE THREAD METRIC CLASS 10.9 FASTENERS AND CLASS 10.0 NUTS AND THROUGH HARDENED FLAT WASHERS, PHOSPHATE COATED, ROCKWELL "C" 38-45.
 USE VALUE IN [] IF USING PREVAILING TORQUE NUTS.

Nominal Thread Diameter mm	Standard Torque		Nominal Thread Diameter mm	Standard Torque					
	Newton-Meters	Foot-Pounds		Newton-Meters	Foot-Pounds				
6	10	[14]	7	[10]	20	385	[450]	290	[335]
7	16	[22]	12	[16]	24	670	[775]	500	[625]
8	23	[32]	17	[24]	27	980	[1105]	730	[825]
10	46	[60]	34	[47]	30	1330	[1470]	990	[1090]
12	80	[101]	60	[75]	33	1790	[1950]	1340	[1450]
14	125	[155]	90	[115]	36	2325	[2515]	1730	[1870]
16	200	[240]	150	[180]	39	3010	[3210]	2240	[2380]
18	275	[330]	205	[245]					

Table 2-1 General Torque Specifications

**LANDOLL CORPORATION
HYDRAULIC FITTING TORQUE SPECIFICATIONS
37° JIC, ORS, & ORB (REV. 10/97)**

THIS CHART PROVIDES TIGHTENING TORQUES FOR HYDRAULIC FITTING APPLICATIONS WHEN SPECIAL TORQUES ARE NOT SPECIFIED ON PROCESS OR DRAWING.
 ASSEMBLY TORQUES APPLY TO PLATED CARBON STEEL AND STAINLESS STEEL FITTINGS ASSEMBLED WITHOUT SUPPLEMENTAL LUBRICATION (AS RECEIVED CONDITION). THEY DO NOT APPLY IF SPECIAL GRAPHITE MOLY-DISULFIDE OR OTHER EXTREME PRESSURE LUBRICANTS ARE USED.
 BRASS FITTINGS AND ADAPTERS - 65% OF THE TORQUE VALUE FOR STEEL. STAINLESS STEEL, ALUMINUM AND MONEL - THREADS ARE TO BE LUBRICATED.
TORQUE IS SPECIFIED IN FOOT POUNDS

PARKER BRAND FITTINGS

Dash Size	37 Degree JIC	O-Ring (ORS)	O-Ring Boss (ORB)
-4	11-13	15-17	13-15
-5	14-16	—	21-23
-6	20-22	34-36	25-29
-8	43-47	58-62	40-44
-10	55-65	100-110	57.5-62.5
-12	80-90	134-146	75-85
-16	115-125	202-218	109-121
-20	160-180	248-272	213-237
-24	185-215	303-327	238-262
-32	250-290	—	310-340

**LANDOLL CORPORATION
HYDRAULIC FITTING TORQUE SPECIFICATIONS
37° JIC, ORS & ORB (REV. 10/97)**

THIS CHART PROVIDES TIGHTENING TORQUES FOR HYDRAULIC FITTING APPLICATIONS WHEN SPECIAL TORQUES ARE NOT SPECIFIED ON PROCESS OR DRAWING.
 ASSEMBLY TORQUES APPLY TO PLATED CARBON STEEL AND STAINLESS STEEL FITTINGS ASSEMBLED WITHOUT SUPPLEMENTAL LUBRICATION (AS RECEIVED CONDITION). THEY DO NOT APPLY IF SPECIAL GRAPHITE MOLY-DISULFIDE OR OTHER EXTREME PRESSURE LUBRICANTS ARE USED.
 BRASS FITTINGS AND ADAPTERS - 65% OF THE TORQUE VALUE FOR STEEL.
TORQUE IS SPECIFIED IN FOOT POUNDS.

AEROQUIP BRAND FITTINGS

Dash Size	37 Degree JIC	O-Ring (ORS)	O-Ring Boss (ORB)
-4	11-12	10-12	14-16
-5	15-16	—	18-20
-6	18-20	18-20	24-26
-8	38-42	32-35	50-60
-10	57-62	46-50	72-80
-12	79-87	65-70	125-135
-14	—	—	160-180
-16	108-113	92-100	200-220
-20	127-133	125-140	210-280
-24	158-167	150-165	270-360
-32	245-258	—	—

Table 2-2 Hydraulic Fitting Torque Specifications

This section supplies information for operation of the carrier. It describes and locates controls and gives general operation procedures. Controls may be operated from either side of Loadoll. Read all instructions, warnings, cautions and danger notes before attempting to operate the carrier. Operators must have proper training before operating the carrier.

Do not operate your Loadoll until a complete inspection has been performed. A defect may cause personal injury, damage to your Loadoll, or time-consuming down time. Operation of your Loadoll is easy, efficient, and dependable if installation was done properly. The engine must be running and the PTO engaged before any controls will become functional.

 WARNING
DO NOT OPERATE THE LOADOLL WITH ANY KNOWN FAULT THAT MIGHT ENDANGER THE OCCUPANTS, NEARBY WORKERS, OTHER TRAFFIC, THE LOAD, OR THE EQUIPMENT.

 WARNING
--

DO NOT OPERATE THE LOADOLL UNTIL YOU HAVE READ THE OPERATOR'S MANUAL AND COMPLETELY UNDERSTAND THE PROPER USE AND FUNCTION OF ALL CONTROLS. IMPROPER USE CAN CAUSE PERSONAL INJURY, DAMAGE TO YOUR SEMI-TRAILER AND CARGO, AND CAUSE TIME-CONSUMING BREAKDOWNS.
--

 DANGER

SERIOUS INJURY OR DEATH MAY RESULT IF A PERSON IS UNDER, IN FRONT OF, OR BEHIND: THE BED, SUBFRAME, REAR BUMPER, OR CHASSIS AT ANY TIME DURING OPERATION OF THE LOADOLL. THE SUBFRAME CAN SWING UP AND THE BED CAN TRAVEL BACK 108 INCHES. ANY OBJECT IN THE SAME AREAS MAY BE DAMAGED, OR CAUSE DAMAGE TO THE LOADOLL.
--

3-1 BED TILT CONTROL

The **BED TILT CONTROL** is the first control located closest to the front of the truck. It is designated on the decal as **TRUCK (See Figure 3-1)**. Pushing **IN** on the control on either side of the truck prepares the Loadoll for loading position. Pulling the control **OUT** causes the Loadoll to move from loading position to transport position.

- | | |
|----------------|---|
| IN | Tilts the front of the bed up until the rear bumper rests on the ground to stabilize the Loadoll for loading purposes. |
| NEUTRAL | No bed tilting will occur. The neutral position will hold the angle the bed is tilted to. The bed must be in the level, transport position before transporting. |
| OUT | Tilts the front of the bed down until the front of the bed and subframe assembly contacts the chassis frame for transport position. |

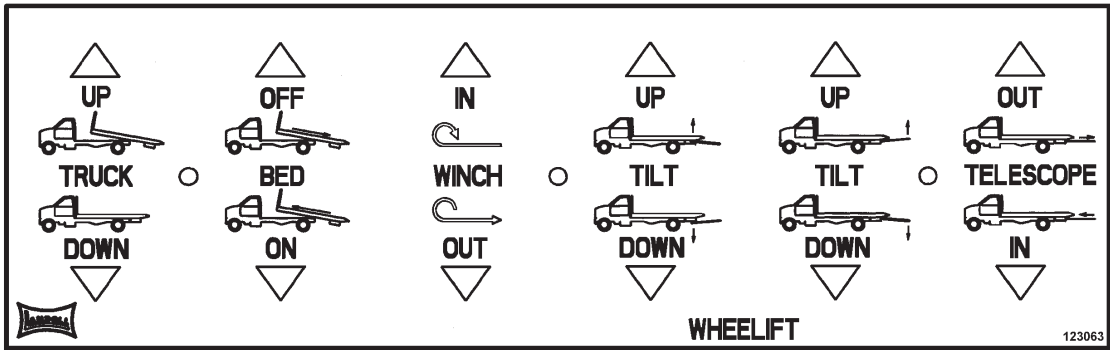

DECAL FOR CONTROL OPERATIONS ON DRIVER'S SIDE

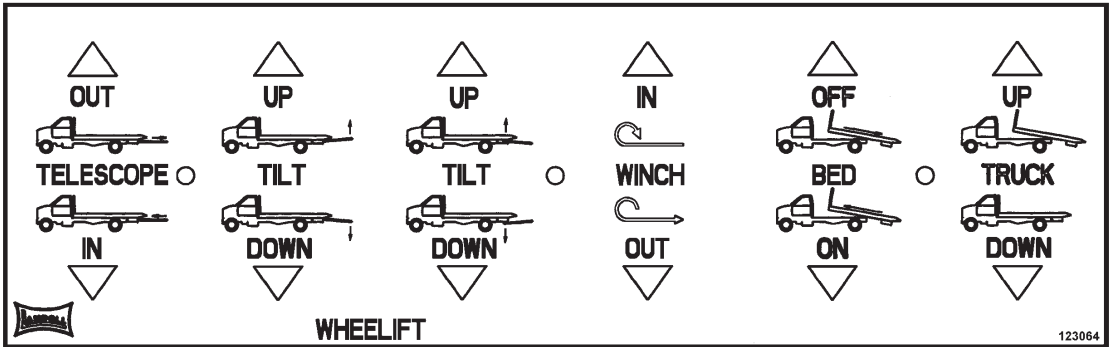

DECAL FOR CONTROL OPERATIONS ON PASSENGER SIDE

Figure 3-1 Decals for Control Operation

3-2 BED SLIDE CONTROL

The **BED SLIDE CONTROL** is the second control from the front of the truck. It is designated on the decal as **BED (See Figure 3-1)**. Pushing **IN** on the control on either side of the truck slides the bed **OFF** the subframe. Pulling the control **OUT** slides the bed back **ON** to the subframe.

IN

Slides the bed back until the bed touches the ground in the full tilt position. Do not slide the bed back unless the bumper is on the ground to stabilize the Loadoll.

NEUTRAL No bed sliding will occur. The rest position will hold the bed in the current position.

OUT Slides the bed forward to the transport position. The bed must be in the forward position before transporting.

3-3 WINCH CONTROLS

CAUTION

DO NOT HANDLE THE WINCH CABLE WHEN THE WINCH IS IN THE ENGAGE POSITION. HANDS OR CLOTHING COULD GET CAUGHT IN CABLE AND BE PULLED INTO THE SPOOL CAUSING SERIOUS PERSONAL INJURY.

DANGER

- 1. THE WINCH IS NOT DESIGNED OR INTENDED TO BE USED FOR LIFTING OR MOVING PEOPLE. USING IT THIS WAY CAN CAUSE SERIOUS INJURY OR DEATH.**
- 2. MAKE CERTAIN THE WINCH CABLE SPOOL CLUTCH IS SET TO ENGAGE AND CLUTCH IS FULLY ENGAGE BEFORE LOAD TENSION IS APPLIED TO WINCH CABLE. NEVER ATTEMPT TO DISENGAGE THE WINCH CABLE SPOOL WHEN THE CABLE IS UNDER TENSION. LOSS OF LOAD CONTROL, PROPERTY DAMAGE, INJURY OR DEATH CAN RESULT.**
- 3. FAILURE TO LEAVE AT LEAST FIVE WINCH CABLE WRAPS ON THE WINCH CABLE SPOOL COULD ALLOW THE CABLE TO COME OFF THE SPOOL, RESULTING IN SERIOUS PERSONAL INJURY OR DEATH.**

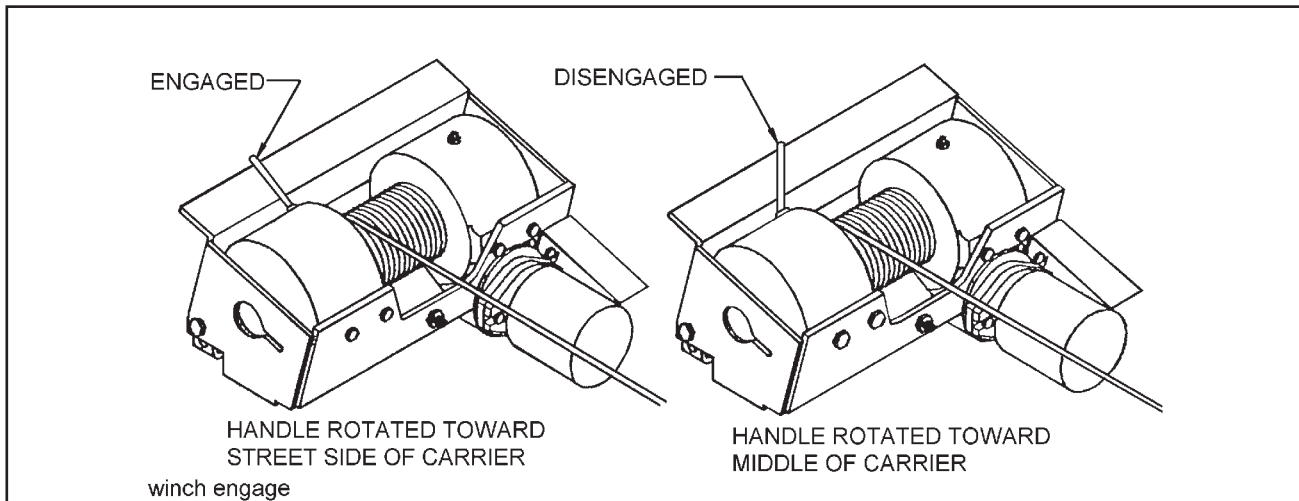

Figure 3-2 Winch Clutch Handle Engagement

3-3.1 The **9,000# WINCH CLUTCH HANDLE** (See **Figure 3-2**) is on the streetside of the winch assembly. The 9,000 pound winch clutch handle has two positions that engage or disengage the winch spool:

DISENGAGE In this position, the winch is disengaged. This allows the spool to “free-wheel”. **This is only used when there is no load on the winch cable.** This feature allows the cable to be pulled out fairly fast and does not require operating the hydraulic system.

ENGAGE In this position, the winch is engaged. Cable may be “power” spooled on or off the winch spool. The winch is now controlled by the Winch Hydraulic Lever.

⚠ CAUTION

A MINIMUM OF 5 WRAPS OF CABLE MUST BE LEFT ON THE WINCH DRUM (SEE FIGURE 3-3).

3-3.2 The **HYDRAULIC WINCH CONTROL LEVER** is the third lever from the front of the truck. It is labeled **WINCH** on the decal (See **Figure 3-1**). This control reels the winch cable IN in the IN position and OUT in the OUT position.

- IN** In this position, the winch reels the winch cable in.
- NEUTRAL** This is the neutral position. This position has some holding power, but cannot be relied upon to hold a load during transport.
- OUT** In this position, the winch reels the winch cable out.

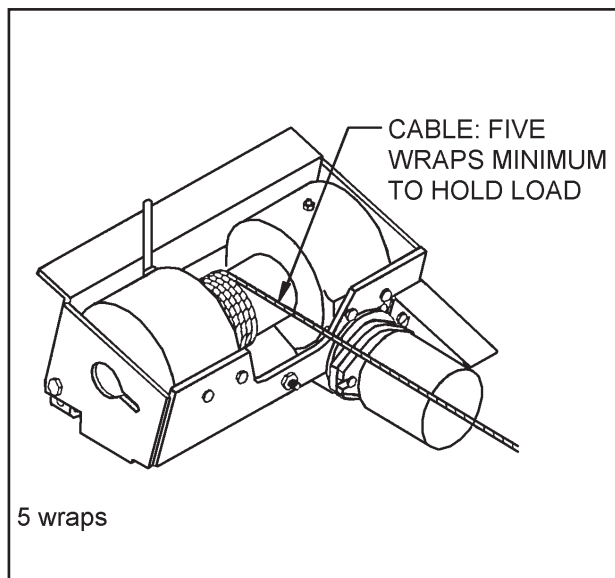

Figure 3-3 Minimum Number of Wraps

3-4 BASIC WHEELIFT CONTROLS (OPTION)

The basic wheelift control option uses the last two controls closest to the rear of the truck. They are labeled TILT and TELESCOPE on the decal (See Figure 3-1).

- IN** In this position, the rear of the wheelift tilts UP.
- NEUTRAL** This is the neutral position.
- OUT** In this position, the rear of the wheelift tilts DOWN.

The **BASIC WHEELIFT TELESCOPE CONTROL** extends the wheelift in or out.

- IN** When the lever is pushed in, the wheelift is extended out from under the bed.
- NEUTRAL** This is the neutral position.
- OUT** When the lever is pulled out, the wheelift is pulled in under the bed.

The **BASIC WHEELIFT TILT CONTROL** tilts the rear of the wheelift up or down.

3-5 SPECIAL WHEELIFT CONTROL (OPTION)

The special wheelift control option uses the TILT controls closest to the WINCH control. It is labeled TILT on the decal (See Figure 3-1).

The **SPECIAL WHEELIFT TILT CONTROL** tilts the front of the wheelift up or down.

- IN** In this position, the front of the wheelift tilts UP.
- NEUTRAL** This is the neutral position.
- OUT** In this position, the front of the wheelift tilts DOWN.

3-6 POWER TAKE-OFF (PTO)

3-6.1 The PTO control is located in the chassis cab. If the Loadoll was installed on the chassis at the Landoll Corporation, the PTO control will be located near the driver. When the PTO is engaged, control pulled up, engine powers a high pressure hydraulic pump, thus providing power to the hydraulic controls.

IMPORTANT

MOST TRUCK TRANSMISSIONS MUST BE IN NEUTRAL AND PARK BRAKE APPLIED WHEN OPERATING THE PTO. FOLLOW INSTRUCTIONS PROVIDED BY PTO MANUFACTURER.

IMPORTANT

NEVER TRANSPORT WITH THE PTO CONTROL ENGAGED. EXTENSIVE DAMAGE MAY RESULT TO THE CHASSIS TRANSMISSION, PTO UNIT, HYDRAULIC PUMP, AND OTHER COMPONENTS.

3-7 BED LOADING

3-7.1 Back the Loadoll up to the item to be retrieved. Align the Loadoll so that the bed is in line with the item to be loaded. Do not back your unit any closer than 10 feet (120 inches) from the item to be retrieved.

DANGER

SERIOUS INJURY OR DEATH MAY RESULT IF A PERSON IS UNDER OR IN THE PATH OF ITEM(S) BEING LOADED, UNLOADED, OR SECURED. ANY OBJECT IN THE SAME AREAS MAY BE DAMAGED, OR CAUSE DAMAGE TO THE LOADOLL.

3-7.2 Shift the transmission to neutral and set parking brake securely.

3-7.3 Shift the PTO in gear. Follow PTO manufacturer's instructions.

3-7.4 Adjust the throttle control to achieve the engine R.P.M. desired.

IMPORTANT

DO NOT EXCEED 1500 ENGINE R.P.M. WITH THE PTO ENGAGED. PUMP AND HYDRAULIC SYSTEM COMPONENTS WILL BE ADVERSELY AFFECTED BY HIGHER R.P.M.'S.

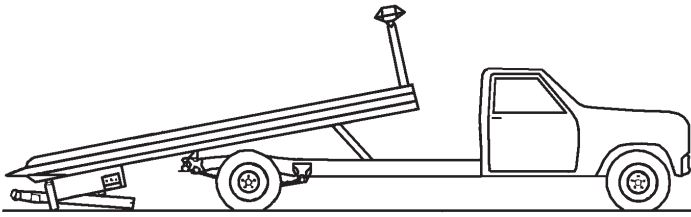

STEP 1

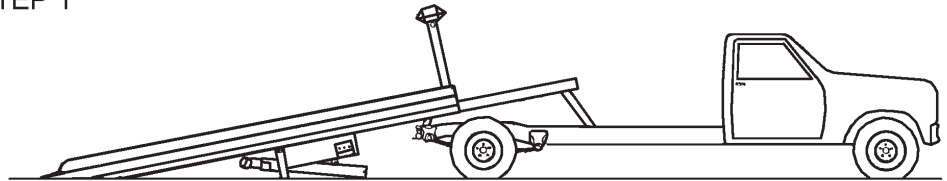

STEP 2

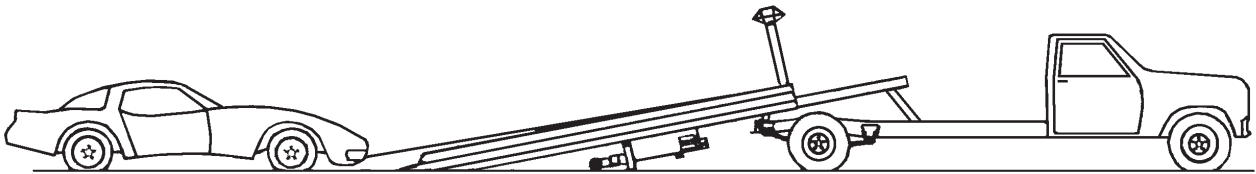

STEP 3

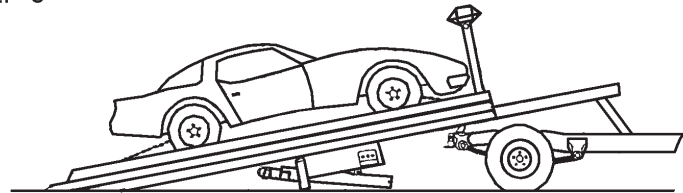

STEP 4

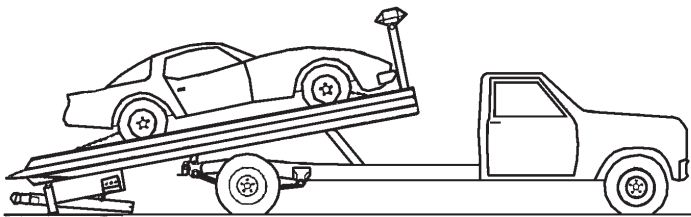

STEP 5

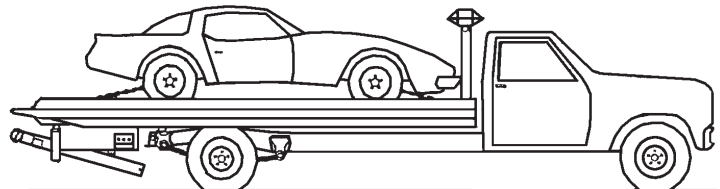

STEP 6

load unload

Figure 3-4 Loading and Unloading Steps

- 3-7.5 Slide bed back enough so that bed comes out of bed hold-downs using the bed slide (bed) controls.
- 3-7.6 Tilt the bed up using the **BED TILT (TRUCK)** controls on either side of the truck until the rear bumper feet firmly contact the ground (See Section 3-1 for proper operation of the control) (See Figure 3-4, step 1).
- 3-7.7 Slide the bed back using the **BED SLIDE (BED)** controls on either side of the truck until the bed touches the ground (See Section 3-2 for proper operation of the control)(See Figure 3-4, step 2).
- 3-7.8 Load the bed. Use the winch to pull the load onto the bed (See Section 3-3 for proper operation of the control) (See Figure 3-4, step 3).

- 3-7.9 Anchor the front and back of the load to the bed key hole slots or D-rings. Use 5/16" "HI-TEST" chain (See Figure 3-4, step 4).

IMPORTANT

NEVER RELY ON THE WINCH CABLE TO TIE DOWN A LOAD.

- 3-7.10 Slide the bed forward only until the load is centered over the rear axle (See Figure 3-4, step 5).
- 3-7.11 Tilt the bed down to the level, transport position. Slide the bed all the way forward now (See Figure 3-4, step 6).
- 3-7.12 Set parking brake of vehicle being hauled.
- 3-7.13 Return the throttle control to idle, and disengage PTO.
- 3-7.14 Check all tie-downs securing the load and attach safety chains before transporting.

3-8 BED UNLOADING

- 3-8.1 Locate the Loadoll on a level, solid surface in an open area.
- 3-8.2 Shift the Loadoll transmission to neutral and set parking brake securely.
- 3-8.3 Shift the PTO into gear.
- 3-8.4 Adjust the throttle to achieve the engine R.P.M. desired.

IMPORTANT

DO NOT EXCEED 1500 ENGINE R.P.M. WITH THE PTO ENGAGED. PUMP AND HYDRAULIC SYSTEM COMPONENTS WILL BE ADVERSELY AFFECTED BY HIGHER R.P.M.'S.

- 3-8.5 Slide bed back enough so the bed comes out of bed hold-downs using the bed slide (bed) controls (See Section 3-2 for proper operation of the control). Continue sliding bed back until load is centered over the rear axles of truck.
- 3-8.6 Tilt the bed up until the rear bumper feet firmly contact the ground (See Figure 3-4, step 5).

- 3-8.7 Slide the bed back until the bed touches the ground (See Figure 3-4, step 4).
- 3-8.8 Secure the winch cable to the load, and remove any cable slack.
- 3-8.9 Remove all securing chains.
- 3-8.10 If the load is a vehicle, shift the loaded vehicles' transmission to neutral, and release parking brake.
- 3-8.11 Operate the winch to allow the load to be removed from the bed of the Loadoll (See Figure 3-4, step 3).
- 3-8.12 After load is off and clear of the bed, secure the unloaded item from moving by blocking it, setting the parking brake, etc.
- 3-8.13 Remove winch line and secure in stowing position. This would entail anchoring to any bed load anchor location and removing any slack in the cable.

IMPORTANT

DO NOT ANCHOR THE WINCH CABLE TO THE REAR BUMPER OR THE TOWBAR.

- 3-8.14 Slide the bed to the halfway forward position (See Figure 3-4, step 1).
- 3-8.15 Tilt the bed fully up to the transport (level) position.
- 3-8.16 Slide the bed to the full forward position.

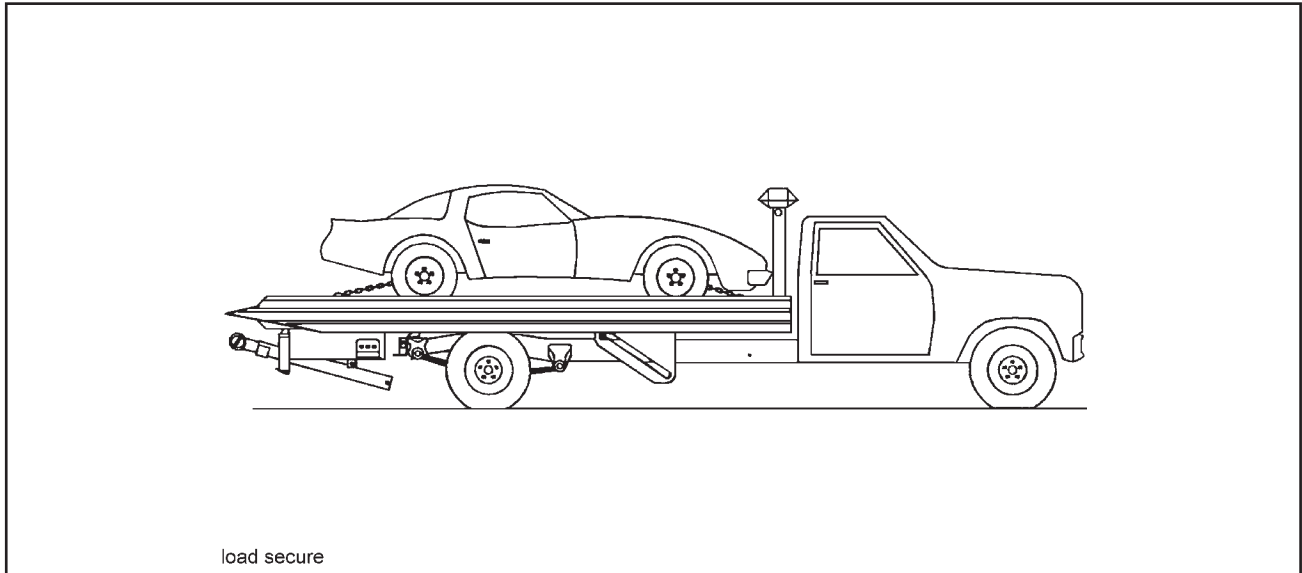

Figure 3-5 Load Secured and Ready for Transport

3-9 LOAD PLACEMENT

3-9.1 In most situations, the load is to be placed as far forward on the bed as possible. If your load is confined to a small area (such as crated item at the weight limit), position so 10% of the load transfers to the front axle, and 90% of the load on the rear axle.

3-10 SECURING LOADS TO BED

3-10.1 All vehicles, machinery, crated goods, or loose parts must be securely tied down to the bed of the Loadoll (**See Figure 3-5**). Key holes are provided in front and rear of the bed to anchor 5/16" chain. Optional bolt-on tie down hooks, side rails, and safety chains and hooks of different lengths are available and can also be used to secure loads.

3-10.2 The front and rear of the load must be secured to the front and to the rear of the bed. Do not rely on the winch to secure the load to the bed (**See Figure 3-5**).

3-10.3 Do not allow any slack in the hold down chains. Slack will allow load to shift. A shifting load will create sufficient momentum to break chains. Remove chain slack by using chain boomers, or other slack adjusters designed to be used for securing loads. Always attach additional safety chains.

3-11 WHEELIFT OPERATION (OPTION)

This section is intended to provide safe, efficient operating instructions for the Loadoll Wheelift. Read all instructions carefully before operating the wheelift. Safety precautions are included to alert you to possible hazardous conditions. Be sure to read and understand all instructions completely before operating the wheelift. See Figure 3-6 for references made in this Section.

DANGER

NEVER ATTEMPT TO CARRY MORE THAN 3,000 POUNDS OF LOAD ON THE WHEELIFT. ALWAYS MAINTAIN AT LEAST FIFTY PERCENT (OR ONE HALF) OF THE TRUCK'S ORIGINAL FRONT AXLE WEIGHT WHEN THE WHEELIFT IS LOADED. FAILURE TO MAINTAIN THE PROPER WEIGHT RATIO OR ATTEMPTING TO CARRY MORE THAN 3,000 POUNDS ON THE WHEELIFT MAY RESULT IN LOSS OF CONTROL OF THE VEHICLE RESULTING IN DAMAGE TO THE LOADOLL, THE WHEELIFT, AND/OR THE TOWED VEHICLE. SERIOUS PERSONAL INJURY OR DEATH MAY ALSO RESULT IF LOSS OF CONTROL OVER THE LOADOLL IS EXPERIENCED.

DANGER

NEVER CRAWL UNDER THE TRUCK OR TOWED VEHICLE DURING WHEELIFT OPERATIONS. NEVER CRAWL UNDER THE WHEELIFT AT ANY TIME. FAILURE TO COMPLY MAY RESULT IN SERIOUS PERSONAL INJURY OR DEATH.

WARNING

NEVER STAND BETWEEN THE TRUCK AND THE TOWED VEHICLE. STANDING BETWEEN THE TRUCK AND THE TOWED VEHICLE MAY RESULT IN SERIOUS PERSONAL INJURY.

3-11.1 Vehicle Retrieval

- a. Back the Loadoll to directly in front of the vehicle to be towed, leaving a minimum of 6 feet between the two vehicles. Set the parking brake on the truck.

IMPORTANT

THE LOADOLL WHEELIFT IS DESIGNED TO BE USED AT VARIOUS ANGLES FROM THE TRUCK; HOWEVER, THE WHEELIFT MUST BE ALIGNED WITH THE WHEELS OF THE TOWED VEHICLE SO THAT WHEN THE WHEELIFT IS EXTENDED, THE WHEELIFT CROSSBAR WILL BE CENTERED BETWEEN THE TIRES OF THE TOWED VEHICLE (SEE FIGURE 3-6).

- b. Tilt the wheelift down so the end goes under the towed vehicle.

IMPORTANT

THE TRUCK BED SHOULD REMAIN IN THE FORWARD POSITION FOR THE ENTIRE WHEELIFT OPERATION.

- c. Adjust wheelift width so wheelift lift arms will be close to outside of towed vehicle's tires.
- d. Be certain that the towed vehicle is unable to move by applying its parking brake or chocking the wheels of the towed vehicle opposite the end by which you intend to tow it.
- e. The wheelift should be extended out so wheelift cross bar is up tight against towed vehicle's tires and touching the ground.

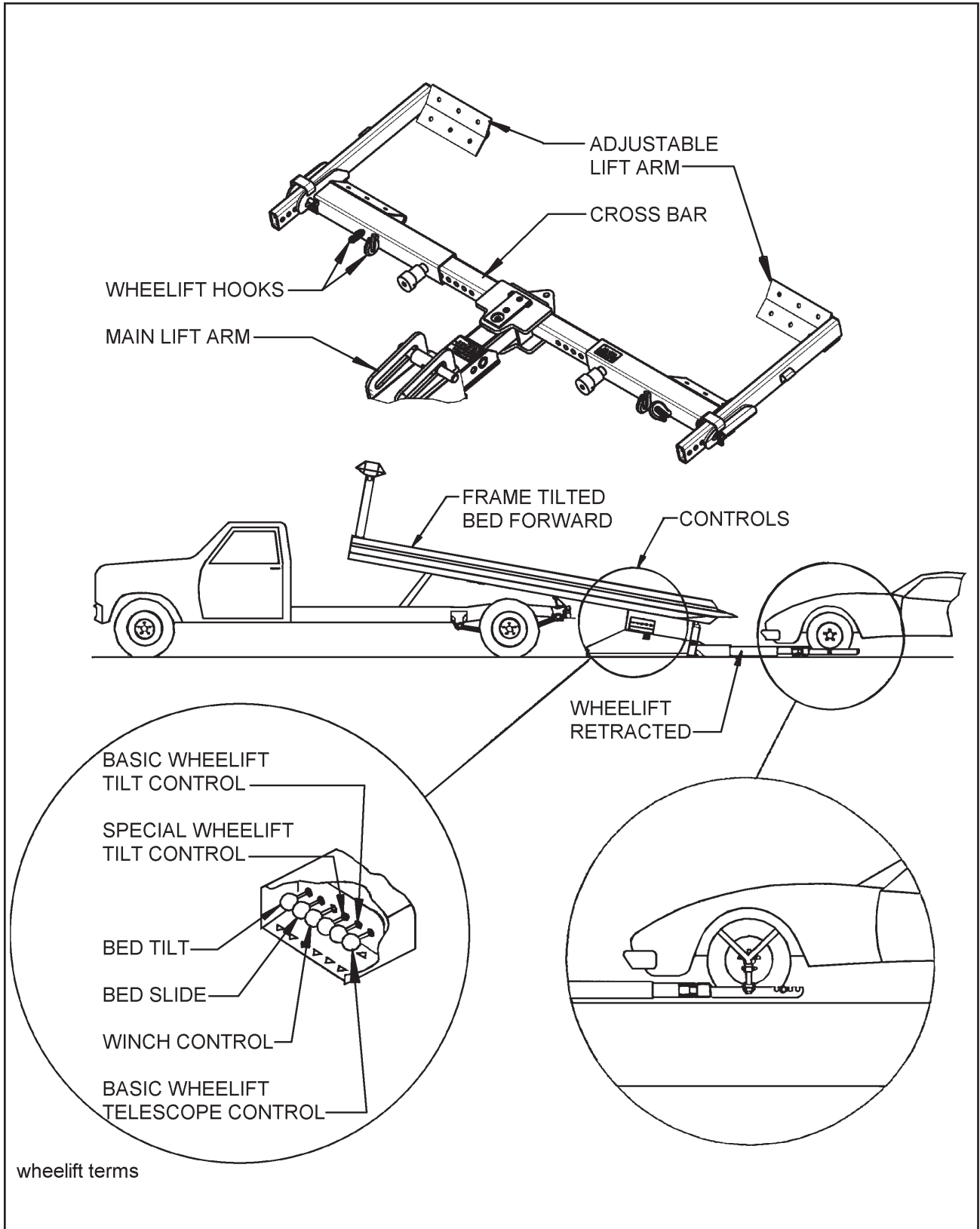

Figure 3-6 Wheelift Terminology

- f. Install the adjustable arms behind both tires and pin into wheelift receivers so the towed vehicle's tires settle down into wheelift, but still provide clearance between crossbar and underneath parts of towed vehicle.
- g. Raise the wheelift just high enough for the tires of the towed vehicle to come off of the ground.

⚠ CAUTION

UNEVEN ROADS, DIPS, BUMPS, AND RAMPS SHOULD BE AVOIDED WHENEVER POSSIBLE. NEVER EXCEED TEN MILES PER HOUR WHEN ONE OF THESE, OR SIMILAR OBSTACLES MUST BE ENCOUNTERED. PROCEED SLOWLY WHILE STOPPING OCCASIONALLY TO CHECK THE POSITION OF THE TOWED VEHICLE. IT MAY BE NECESSARY TO RAISE OR LOWER THE WHEELIFT SLIGHTLY TO CLEAR ONE OF THESE TYPE OBSTACLES. FAILURE TO EXERCISE THESE CAUTIONS WHEN ENCOUNTERING THESE TYPES OF OBSTACLES MAY RESULT IN LOSS OF THE TOWED VEHICLE FROM THE WHEELIFT RESULTING IN DAMAGE TO THE WHEELIFT AND/OR THE TOWED VEHICLE.

⚠ CAUTION

ALWAYS STRAP THE TIRES OF THE TOWED VEHICLE TO THE WHEELIFT BEFORE TRANSPORTING. FAILURE TO STRAP THE TIRES TO THE WHEELIFT MAY RESULT IN LOSS OF THE TOWED VEHICLE DURING TRANSPORT.

- h. Place the latches of the retaining straps on the hooks of the wheelift arms and loop the retaining straps over each tire. Pull the straps down tight, release the brakes of the towed vehicle, and remove the wheel chocks.

- i. Retract the wheelift leaving enough clearance between the truck and the towed vehicle that the towed vehicle will not interfere with the trucks cornering capabilities.
- j. Connect safety chains and check that vehicle is ready to be towed.
- k. Raise or lower the wheelift as necessary to provide ample clearance between the ground and the front and the rear of the towed vehicle.

3-11.2 Vehicle Disconnection

- a. Locate the towed vehicle in an open, level area. Apply the Loadoll's parking brakes. Disconnect safety chains and place back in storage compartment. Remove the retaining straps from the tires.
- b. Lower the wheelift until the towed vehicle is resting on the ground.

IMPORTANT

THE BED OF THE LOADOLL SHOULD REMAIN IN THE FULLY FORWARD POSITION FOR THE ENTIRE WHEELIFT OPERATION.

- c. Set the brakes of the towed vehicle and chock the wheels so it will not roll.
- d. Extend the wheelift a little to provide some slack for the adjustable lift arms.
- e. Remove the adjustable lift arms from behind the towed vehicle's tires and place in storage holders.

⚠ CAUTION

ALWAYS STRAIGHTEN THE CROSSBAR OF THE WHEELIFT SO IT IS PARALLEL WITH THE REAR OF THE TRUCK BEFORE RETRACTING IT FULLY INTO THE LOADOLL BED. IF THE CROSSBAR OF THE WHEELIFT IS ANGLED EVEN SLIGHTLY, IT WILL SNAP TO A STRAIGHT POSITION WHEN IT CONTACTS THE REAR OF THE BED. THIS COULD DAMAGE THE CROSSMEMBER AND CAUSE SERIOUS PERSONAL INJURY TO ANYONE STANDING NEAR THE CROSSMEMBER.

- f. Retract the wheelift completely.
- g. Move the Loadoll forward if there is not enough room to lift the wheelift up.
- h. Raise the wheelift to a horizontal position, making sure that the rear lights of the Loadoll are not obstructed from sight in any way before moving the Loadoll.

3-12 COLD WEATHER OPERATION

3-12.1 Cold weather causes lubricants to congeal, insulation and rubber parts to become hard, which may lead to problems found in bearings, electrical systems, and air systems. Moisture attracted by warm parts can condense, collect and freeze to immobilize equipment. The vehicle operator must always be alert for indicators of cold weather malfunctions.

3-12.2 During any extended stop period, neither the service nor parking brake should be

used as they can freeze up. Use wheel chocks to secure the vehicle from moving.

3-12.3 Check all structural fasteners, air system fittings, gaskets, seals and bearings for looseness that can develop due to contraction with cold. Do not over-tighten.

3-12.4 Check tire inflation. Tire inflation decreases when the temperature decreases.

3-12.5 Periodically check drain holes in the storage compartments. They must be open at all times to avoid moisture entrapment.

3-13 HOT WEATHER OPERATION

3-13.1 Hot weather operation can cause expansion of parts, resulting in tightening of bearings, fasteners, and moving parts. Failure of gaskets or seals can occur.

3-13.2 The vehicle should be parked in the shade if possible. Long exposure to the sun will shorten service life of rubber components (i.e., tires, light and hose grommets, hoses, etc.) and paint life.

3-13.3 Check tire pressure early in the day before beginning operations while the tire is cool. Put all valve stem caps back on after checking.

3-13.4 If the area is extremely humid, protect electrical terminals with ignition insulation spray. Coat paint and bare metal surfaces with an appropriate protective sealer.

This section contains instructions necessary for proper maintenance of the Loadoll. The Loadoll is designed for years of service with minimal maintenance. However, proper maintenance is important for durability and safe operation and is an owner/user responsibility.

⚠ DANGER

OPERATING THE VEHICLE WITH DEFECTIVE, BROKEN OR MISSING PARTS MAY RESULT IN SERIOUS INJURY OR DEATH; DAMAGE TO THE VEHICLE, ITS CARGO, OR PROPERTY IN ITS PATH.

⚠ DANGER

SERIOUS INJURY OR DEATH MAY RESULT IF A PERSON IS UNDER, IN FRONT OF, OR BEHIND: THE BED, SUBFRAME, REAR BUMPER, OR CHASSIS AT ANY TIME DURING OPERATION OF THE LOADOLL. THE SUBFRAME CAN SWING UP AND THE BED CAN TRAVEL BACK AN ADDITIONAL 108 INCHES. ANY OBJECT IN THE SAME AREAS MAY BE DAMAGED, OR CAUSE DAMAGE TO THE LOADOLL.

IF MAINTENANCE IS REQUIRED IN ANY OF THESE AREAS, BLOCK BOTH ENDS OF THE SUBFRAME TO PREVENT LOWERING OF THE REAR BUMPER AND THE FRONT OF THE SUBFRAME SECURELY. LOCK THE BED IN PLACE TO PREVENT SLIDING BY POSITIONING THE TAIL PLATE ON THE GROUND OR ANCHORING THE BED TO THE SUBFRAME WITH SAFETY CHAINS.

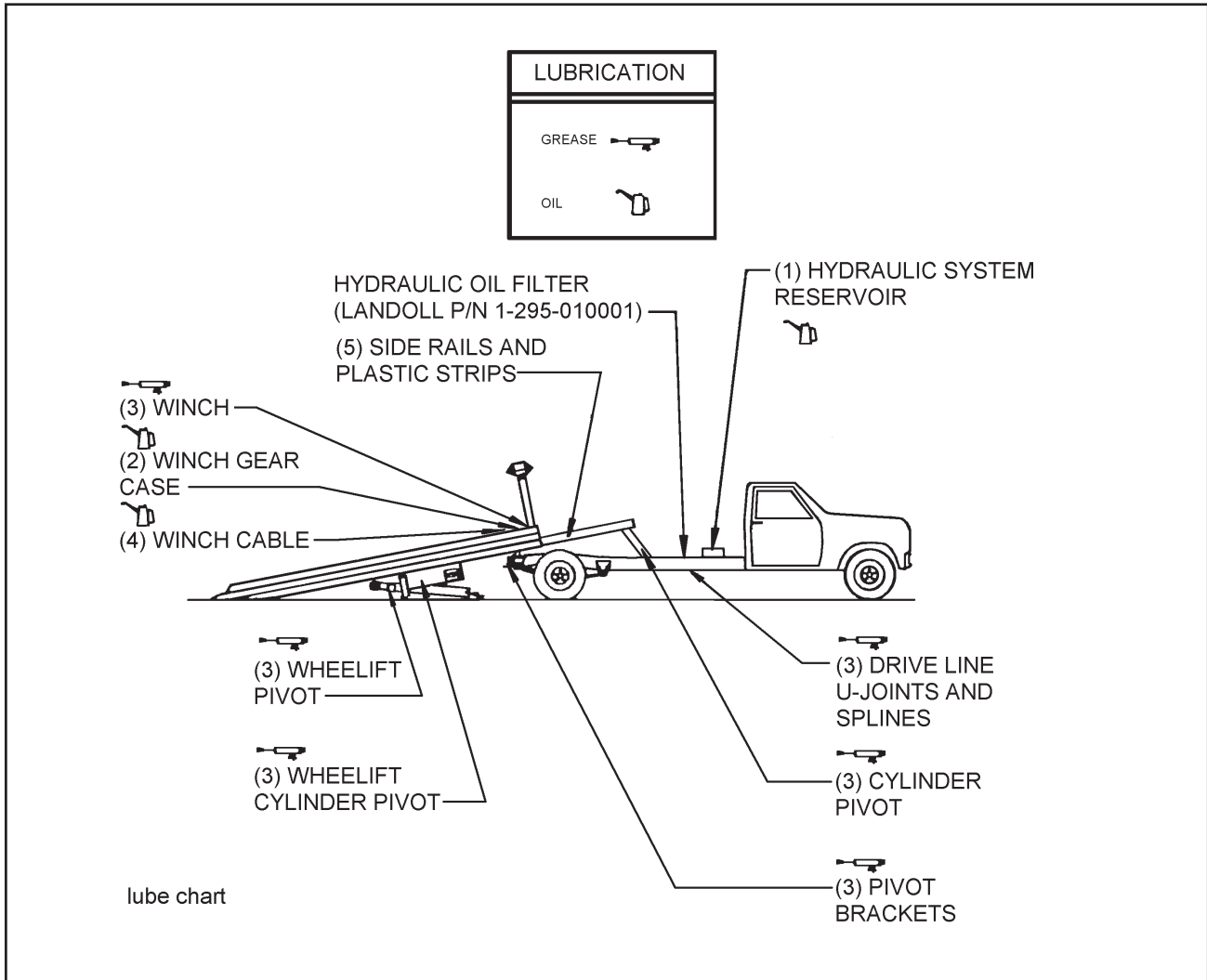

Figure 4-1 Lubrication Points

LUBE	SEASON	BRAND AND PRODUCT (WEIGHT AND/OR TYPE)			
		AMOCO	EXXON	PHILLIPS	TEXACO
1	ALL YEAR	Rycon MV	HDX Plus 10W	Mangus Oil A KV 5W-20	Rando HD-AZ
2	ALL YEAR	Permagear EP 460 SAE 140	Spartan 460 SAE 140	Phil Gear Lube 460 SAE 140	Meropa 460 SAE 140
3	ALL YEAR	Lit-Multi-purpose Grease	Rondex Multi-purpose Grease	Phil Lube M.W. Grease	MarFax All Purpose
4	ALL YEAR	Industrial Oil 32	Estic 32	Condor 32 or Magnus 32	Regal Oil R&O 32
5	ALL YEAR	The nylatron and plastic strips are impregnated with a special lubricant - thus they are self lubricating. If chatter or squeal occurs, use silicone dry spray or other lubricant that does not attract dirt and grit.			

Table 4-1 Lubrication Specifications

4-1 MAINTENANCE SCHEDULE

Loadoll maintenance includes periodic inspection and lubrication. **Table 4-2, Maintenance Schedule**, lists the recommended maintenance and lubrication tasks by time interval and by accumulated mileage (use whichever occurs first).

4-1.1 Inspection

- a. Inspect the vehicle and deck system periodically for damage or signs of pending failure. Damaged or broken parts must be repaired or replaced at once. Determine the cause of any binding or hydraulic leakage at once. Correct the problem before using the vehicle.
- b. Use the Troubleshooting Guide to check for “SYMPTOMS” and “PROBLEMS” of any vehicle system not functioning correctly, or where wear, distortion, or breakage are found. Administer “REMEDY” according to the right-hand column of the Troubleshooting Guide.

4-1.2 Lubrication

Figure 4-1 and Table 4-1 details lubrication points and intervals, method of application, and lubricant required, and illustrates the location of each part to be lubricated. During inspections of the vehicle, if lubricants are found to be fouled with dirt or sand, those parts should be cleaned with paint thinner, dried, and relubricated immediately. Dirt in a lubricant forms an abrasive compound that will wear parts rapidly.

WARNING

PAINT THINNER AND OTHER SOLVENTS ARE FLAMMABLE AND TOXIC TO EYES, SKIN, AND RESPIRATORY TRACT. AVOID SKIN AND EYE CONTACT. GOOD GENERAL VENTILATION IS NORMALLY ADEQUATE. KEEP AWAY FROM OPEN FLAMES OR OTHER COMBUSTIBLE ITEMS.

4-2 MAINTENANCE PROCEDURES

4-2.1 Tools and Equipment. Tools, equipment, and personnel normally found in a facility capable of making truck repairs will be adequate for maintenance of the vehicle. No other special tools or equipment should be necessary.

4-2.2 Standard Torque Values. **Tables 2-1 and 2-2** lists torque values for standard hardware and is intended as a guide for average applications involving typical stresses and mechanical surfaces. Values are based on the physical limitations of clean, plated, and lubricated hardware. In all cases, when an individual torque value is specified, it takes priority over values given in this table. Replace original fasteners with hardware of equal grade.

WARNING

1. PAINT THINNER AND OTHER SOLVENTS ARE FLAMMABLE AND TOXIC TO EYES, SKIN, AND RESPIRATORY TRACT. AVOID SKIN AND EYE CONTACT. GOOD GENERAL VENTILATION IS NORMALLY ADEQUATE. KEEP AWAY FROM OPEN FLAMES OR OTHER COMBUSTIBLE ITEMS.

2. DO NOT ALLOW ALUMINUM BRIGHTENER OR OTHER ACID COMPOUNDS TO CONTACT HYDRAULIC HOSES. THE HOSE COVERS ARE SUSCEPTIBLE TO ACID DETERIORATION.

NORMAL OPERATING SERVICE INTERVALS ^a								
SERVICE INTERVAL :	TIMES	1st 5 Hrs	Weekly	Monthly	6 Months	Yearly	LUBE #	NOTES
ITEM	MILES	50	500	2,000	12,000	25,000		
HYDRAULIC OIL		I	I			R	1	c
HYDRAULIC FILTER		R			R			
WINCH GEAR CASE LUBE		I		I		R	2	c
HOSES		I		I				
LIGHTS		I	I					
WIRING & CONNECTIONS		I		I				
FASTENERS		I, T		I				b
BED SLIDE PLASTIC STRIPS		I		I			5	c
SUBFRAME AND WHEELIFT PIVOTS		L		L			3	c
SUBFRAME AND WHEELIFT CYLINDER PINS		L			L		3	c
WINCH CABLE ASSEMBLY		I	I	I, L			4	c
DRIVE SHAFT U-JOINTS		L	SEE TRUCK OWNER'S MANUAL FOR SERVICE INTERVALS					
DRIVE SHAFT SLIP JOINTS		L						
TIRE INFLATION & WEAR		I	I					d
WHEEL LUG NUTS		I, T	SEE TRUCK OWNER'S MANUAL FOR SERVICE INTERVALS					
I – Inspect, R – Replace, T– Tighten/ Adjust Torque, L – Lubricate, C – Clean								
NOTES:								
a. Perform at the time shown. Shorten service intervals when operating in severe or dirty conditions.								
b. See Tables 2-1 and 2-2 (General and Hydraulic Fitting Torque Charts) for correct torque.								
c. See Table 4-1 (Lube Specification Chart) for recommended lubricant.								
d. See certification sticker on driver's side door jamb for proper inflation requirements.								

Table 4-2 Maintenance Schedule

4-2.3 Cleaning

- a. Wash carrier to remove all accumulated dirt and grime. For washing aluminum, use water and a mild, non-abrasive soap or detergent such as those recommended for automotive finishes; or a non-etching, non-abrasive aluminum cleaner. Use a soft cloth or sponge. Rinse with clear water and dry with a chamois or cloth to prevent spotting or streaking. Wax with a liquid or paste wax recommended for the care of automotive finishes. Wax should be applied every three to six months or more frequently if exposed to extreme weather.
- b. Clean the sliding surfaces with solvent or mineral spirits every six months or more frequently if exposed to extreme dirt or weather conditions. The slide wear strips are impregnated with a special lubricant, however, additional lubrication may be required to prevent chattering or squealing. **See Lubrication Points and Specifications in Figure 4-1 and Table 4-1 .**
- c. After disassembling any components, thoroughly clean dirt and old lubricant from all parts. Do not use a wire brush on any bearing parts or surfaces — use a stiff bristle brush. Do not use compressed air, or spin bearing parts when cleaning. These practices can throw solvents, dirt, or metal particles into your eyes. Dry clean parts with lint free, clean, soft, absorbent, cloth or paper. Wash and dry hands.
- d. Inspect seals, seal wiping surfaces, bearing caps, and bearing cones for wear, pitting, chipping, or other damage.
- e. Use Troubleshooting Guide to check for **“SYMPTOMS”** AND **“PROBLEMS”** of any carrier system not functioning correctly, or where wear distortion, or breakage can be found. Administer **“REMEDY”** according to right-hand column of Troubleshooting Guide (**See Section 5**).

4-3 FRAME AND DECK

4-3.1 Repairing Structural Defects

If any structural defect is found, the fault must be corrected before further use of the vehicle. To continue usage could endanger the vehicle, its load, personnel, traffic, and properties. Inspect the deck daily for broken or missing attachments. Replace any defective parts promptly.

4-4 HYDRAULIC SYSTEM

- 4-4.1 Check the hydraulic oil level weekly, or after any leakage. See **Table 4-1** for proper hydraulic oil.
- 4-4.2 Check the hydraulic oil level by sliding the deck back enough to gain access to the reservoir cap. Have the bed level with the chassis frame, and the wheelift fully retracted. Shut off the engine. Proper oil level is 2” below top of oil reservoir. Filling to the top will result in overflow when the bed is slid forward.
- 4-4.3 If a cylinder seal leaks, disassemble the cylinder and determine the cause of the leak. Small scores caused by chips or contaminated fluid can usually be worked out with fine emery cloth to avoid re-occurring of the trouble. Any time a component is opened up, or whenever any seal replacement is necessary, it is advisable to thoroughly clean all components and replace all seals in that component. Seal kits are available from your Landoll dealer.

4-5 ELECTRICAL SYSTEM

4-5.1 Maintenance of the electrical system consists of inspection and minor servicing. Any wire, connection or electrical component showing signs of corrosion, wear, breakage or unraveling must be repaired or replaced.

4-5.2 Frayed or unraveling wire must have the defective section removed and replaced with wire of the same color and gauge. Seal all connections and insulate.

4-5.3 Corroded terminals must have the corrosion removed, source of corrosion neutralized and the terminals resealed, protected, and insulated.

4-5.4 Fuse or circuit breaker burn-out or blow-out usually indicates an electrical short-circuit, although a fuse can occasionally fail from vibration. Insert a second fuse or reset the breaker. If this fuse immediately burns out or the breaker trips, locate the cause of the electrical short and repair.

4-5.5 A light that repeatedly burns-out usually indicates a loose connection, poor system ground, or a malfunctioning voltage regulator. Locate the source of the problem and repair. System grounds must be grounded to bare metal surfaces. Paint, grease, wax, and other coatings act as insulators. Replacement lamps must be equivalent to the factory installed lamp.

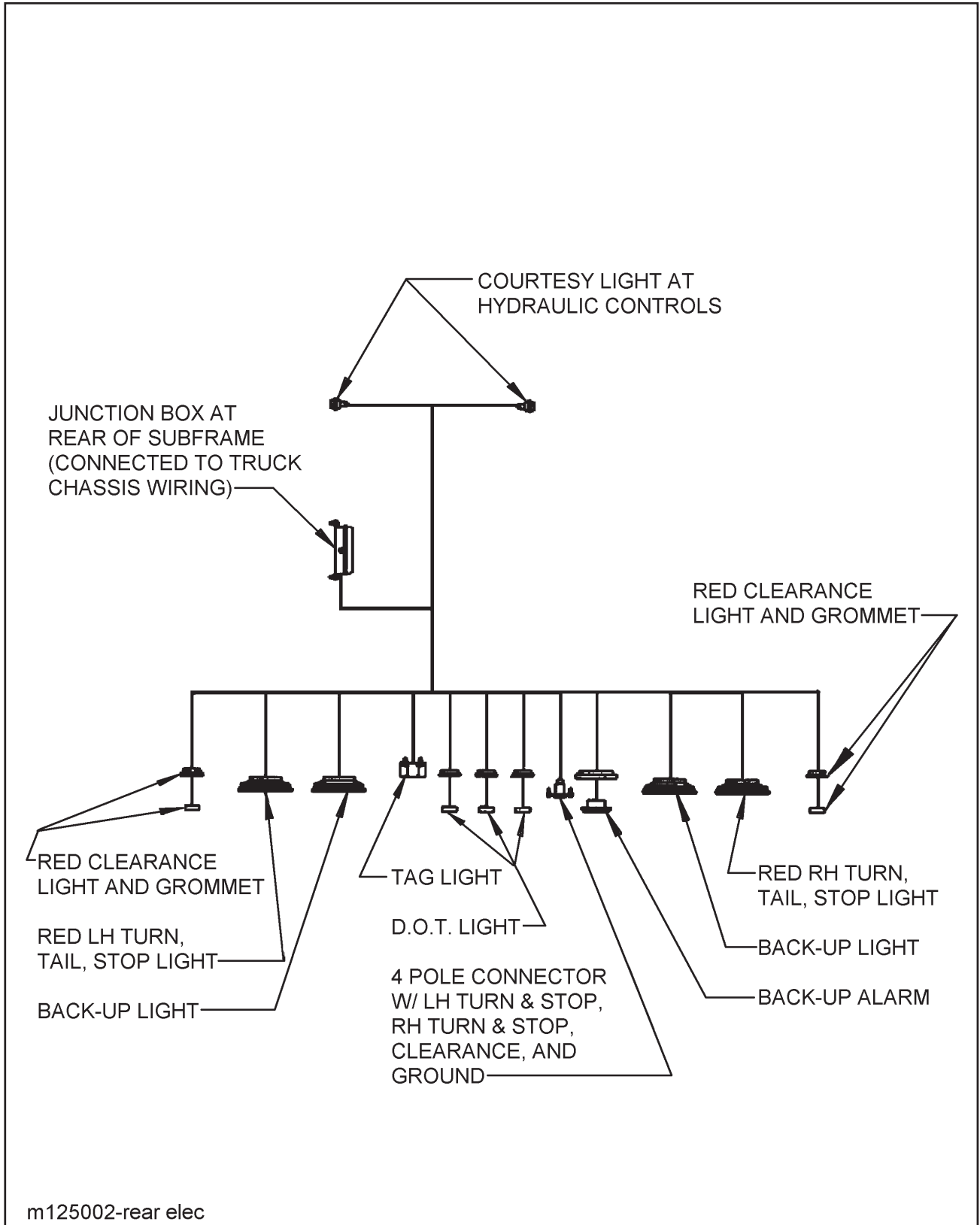

Figure 4-2 Loadoll Electrical System Schematic - Rear of Subframe

MOST LIGHT BARS HAVE THE FOLLOWING FUNCTIONS:
 LH TURN & STOP - YELLOW RH TURN & STOP - GREEN
 CLEARANCE - BROWN GROUND - WHITE
 FLASHERS - BLUE WORK LIGHTS - BLACK
 ROTATORS - RED
 NOTE: COLORS ARE PROBABLY DIFFERENT IN
 THE LIGHT BAR HARNESS THAN THEY ARE IN
 THE CARRIER HARNESS. THE LIGHT BAR
 HARNESS GOES DOWN TO THE JUNCTION BOX.

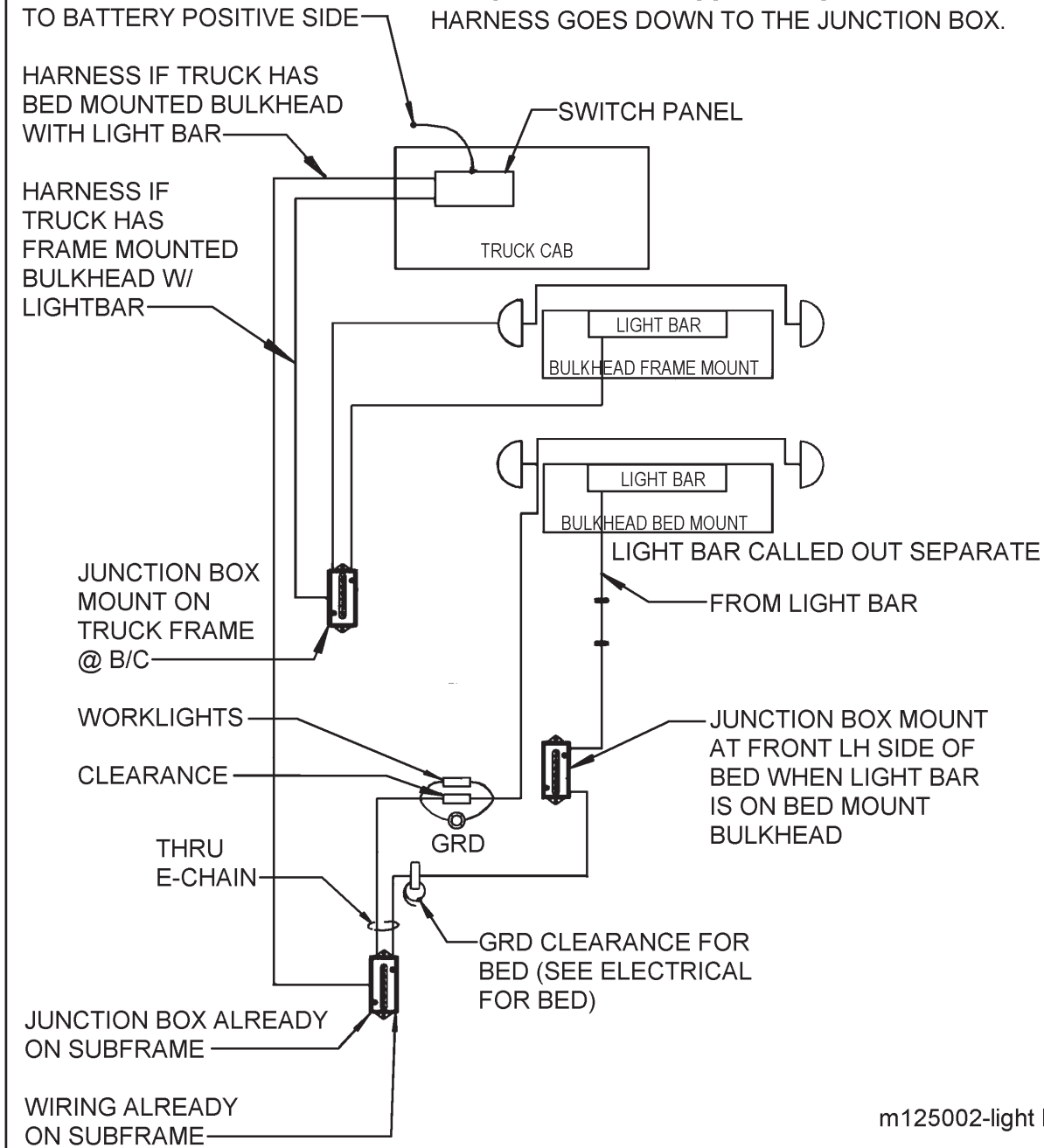

Figure 4-3 Loadoll Electrical System Schematic - for Light Bar and Work Lights

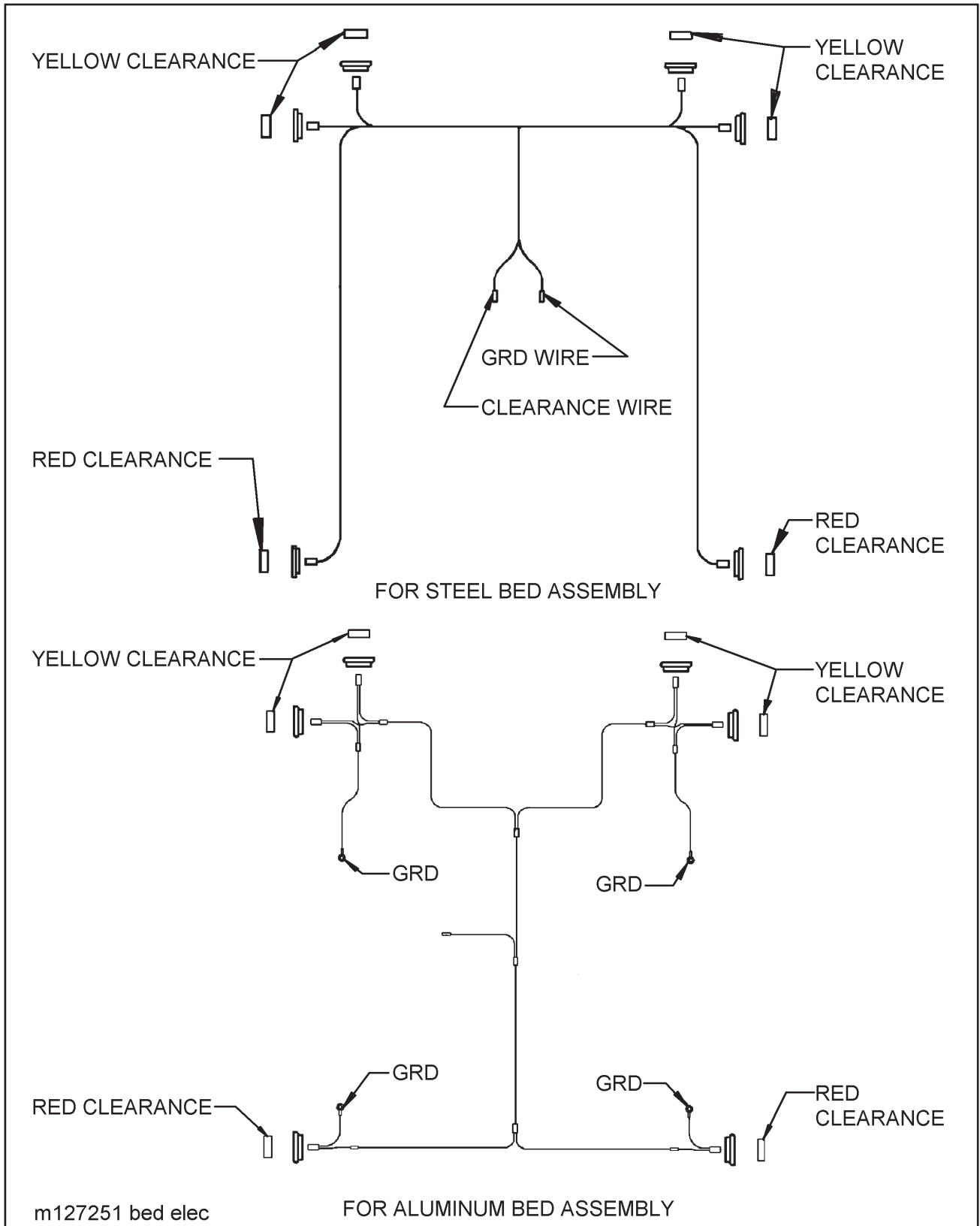

Figure 4-4 Loadoll Electrical System Schematic - for Beds

Troubleshooting should be performed by a trained technician. Landoll Corporation is not responsible for equipment that is improperly maintained. Contact an authorized Landoll Service center for servicing.

5-1 ELECTRICAL

Most electrical system problems show up as a burned out light or fuse, or inoperative electrical component. Wiring, grounds, or components may be at fault. Locate the symptom in this section that best identifies your electrical problem. Check out each possible problem under that symptom. If the problem cannot be located, see an automotive electrical specialist. For maintenance procedures, see **Section 4-5**.

SYMPTOM

PROBLEM: REMEDY

NO LIGHTS

Fuse blown: replace fuse.

Connection at plug-in: tighten connection.

Broken or corroded wires: replace wire.

Ground wire loose: clean and tighten ground.

Dirty or corroded 7-way connector or receptacle: Clean w/ wire brush or replace connector or receptacle.

LIGHTS FLICKERING

Wires shorted or loose: locate, insulate, replace, or tighten.

LIGHTS DIM

Voltage difference between trailer & tractor: tractor supply wire or circuit components are too low a capacity. - Enlarge wire or component. Match bulbs with tractor voltage.

LIGHTS BRIGHT & BURN OUT

Ground wire disconnected: connect ground wire.

Voltage difference between trailer & tractor: tractor supply wire or circuit components are too low a capacity. - Enlarge wire or component. Match bulbs with tractor voltage.

FUSE BLOW-OUT OR CIRCUIT BREAKER TRIPPING

Vibration: locate source of vibration and repair.

Short circuit: replace fuse and try all accessories. If fuse blows right away, locate short and repair.

LAMP BULB BURN OUT

Vibration: locate source of vibration and repair.

Short circuit: replace fuse and try all accessories. If fuse blows right away, locate short and repair.

Loose connection: check lamp sockets and ground connections.

Intermittent short: locate short and repair.

Improper voltage: check voltage regulator output.

ELECTRICAL SYSTEM CONTINUED

SYMPTOMS

PROBLEM: REMEDY

REMOTE CONTROL WINCH:
DOES NOT OPERATE

Fuse blown: replace fuse.
Defective switch: repair and replace.
Broken or corroded wires: replace wire.
Ground wire loose or bad: clean and tighten ground or replace.

OPERATES ONE WAY ONLY

Incorrect wiring: confirm proper wiring (**See Figures 4-2 thru 4-4**)
Defective switch: repair and replace.
Broken or corroded wires: replace wire.

OPERATES WRONG DIRECTION

Wires reversed on solenoid: Reverse wires

5-2 TIRES - WHEELS - SUSPENSION

Most tire, wheel, and suspension related problems are due to excessive loads, extreme conditions, and improper maintenance. Tire, wheel, and suspension problems can be easily detected and solved by checking the following guide.

SYMPTOM

PROBLEM: REMEDY

VIBRATIONS WHILE DRIVING

Improper tire inflation: inflate to proper pressure.
Tires cupped or have flat spots: replace tires.
Wheels bent or loose: replace or tighten.
Tires incorrectly mounted: remount.
Mud in wheels: clean wheels.
Tire(s) out of balance: balance tires.
Brakes dragging: locate cause and repair.
Object(s) stuck between duals: remove object(s).

RAPID TIRE WEAR/DETERIORATION:

CENTER TREAD WEAR

Over inflation: deflate to correct inflation.

SHOULDER TREAD WEAR - BOTH
SHOULDERS

Under inflation: increase inflation to correct PSI. Check axle alignment.
Overloading: loads are above rated tire capacity. DO NOT load above rated tire capacity.

OVERALL TREAD WEAR

Overloading: check tire load rating.
High speeds: adjust speed according to road and load conditions.
Incorrect dual matching: properly match dual tires.

TIRE FLAT SPOTS

Quick stops: adjust braking practices.
Grabbing brakes: adjust brakes properly.
Worn or loose wheel bearings: adjust or replace as needed.
Out of balance wheels and tire: balance wheels and tires.
Check ABS system function.

TIRES - WHEELS - SUSPENSION (CONTINUED)

SYMPTOMS

UNEVEN WEAR

PROBLEM: REMEDY

Suspension bushings worn: replace bushings.

Worn or loose wheel bearings: adjust or replace as needed.

Out of balance wheels and tires: balance wheels and tires.

RIM FAILURE*:

CRACKING

Overinflated tires: deflate tire to proper PSI.

High speeds: adjust speed according to road and load conditions.

High speed cornering: adjust cornering practices.

Overloading: check rim load rating.

*IN ALL INSTANCES OF RIM FAILURE, REPLACE THE RIM IMMEDIATELY!

BENDING OR WARPING

Curb-hopping or potholes: adjust turning practices and adjust speed accordingly with road conditions.

Improper tightening sequence: follow proper tightening sequence.

BROKEN STUDS*

Over tightening: use correct torque when mounting.

Under torque: Use correct torque and tightening sequence when mounting.

Rim not seated: Adjust rim to equal distance with hub.

5-3 HYDRAULIC SYSTEM

Most hydraulic system failures follow the same pattern: a gradual or sudden loss of pressure or flow with a resulting loss of cylinder or motor power. Any one of the system's components may be at fault. By following step-by-step procedures, the trouble can be located in a short time.

SYMPTOM

SYSTEM INOPERATIVE

PROBLEM: REMEDY

Not enough oil in system: fill, check for leaks.

Wrong oil in system: change oil, see specifications.

Filter dirty or clogged: drain oil and replace filter.

Hydraulic lines dirty or collapsed: clean or replace as necessary.

Air leaks in pump suction line: repair or replace as necessary.

Worn or dirty pump: clean, repair or replace. Check for contaminated oil. Drain and flush.

Badly worn components: examine for internal leakage. Replace faulty components. Check for cause of wear.

Leakage: check all components, and relief valve for proper settings.

Excessive load: check unit specifications for load limits.

Slipping or broken pump drive: repair or replace couplings. Check for alignment.

HYDRAULIC SYSTEM (CONTINUED)

SYMPTOM

SYSTEM OPERATES
ERRATICALLY

PROBLEM: REMEDY

Air in the system: check suction side of system for leaks. Repair leaks.

Cold oil: allow ample warm-up time. Use proper weight oil for operating temperature.

Dirty or damaged components: clean or repair as needed.

Restriction in filters or lines: clean and/or replace filter or lines.

Not enough oil in system: fill and check for leaks.

SYSTEM OPERATES SLOWLY

Oil viscosity too high, or "cold oil": Allow oil to warm up before operating.

Low pump drive speed: increase engine speed (check pump owners manual for specifications).

Low oil level: check reservoir and add oil as necessary.

Air in system: check suction side for leaks. Repair leaks.

Badly worn pump, valves, cylinders, etc.: repair or replace faulty component(s) as necessary.

Restrictions in lines or filter: clean and/or replace filter or lines.

Improper adjustments: check orifices, relief valves, etc. Adjust as necessary.

Oil leaks: tighten fittings. Replace seals, gaskets and damaged lines.

SYSTEM OPERATES TOO FAST

Wrong size or incorrectly adjusted restrictor: Replace or adjust as necessary.

Engine running too fast: reduce engine speed.

OVER HEATING OF
OIL IN SYSTEM

Oil passing thru relief valve for excessive time: Return control valve to neutral when not in use.

Incorrect, low, dirty oil: use recommended oil. Fill reservoir with clean oil. Replace filter.

Engine running too fast: reduce engine speed.

Excessive component internal leakage: repair or replace component as necessary.

Restriction in filters or lines: clean and/or replace filter or lines.

Insufficient heat radiation: clean dirt and mud from reservoir and components.

Malfunctioning component: repair or replace.

HYDRAULIC SYSTEM (CONTINUED)

SYMPTOM

PROBLEM: REMEDY

FOAMING OF OIL

Incorrect, low, or dirty oil: replace, clean or add oil as needed.

Water in oil: replace oil

Air leaks: check suction line and component seals for suction leaks. Replace defective parts.

NOISY PUMP

Low, incorrect, foamy oil: replace, clean, or add oil as needed.

Suction line plugged: clean out obstruction or replace line. Flush system, replace filter.

Pump damaged: repair or place.

LEAKY PUMP

Damaged or worn shaft seal: Replace seal and/or shaft and check for misalignment.

Loose or broken parts: Tighten or replace.

CYLINDERS MOVE WITH
CONTROL VALVE IN
NEUTRAL POSITION

Leaking cylinder seals or fittings: Replace worn seals or fittings.

Control valve not centering when released: Check linkage for binding and repair.

Valve damaged: Repair or replace.

CONTROL VALVE LEAKS

Seals damaged or worn: Replace.

CYLINDER LEAKS

Seals worn or damaged: Replace.

Rod damaged: Replace.

Barrel damaged: Replace.

CYLINDERS DO NOT FUNCTION,
OR CREEP WITH PTO
DISENGAGED

Leaking fittings or cylinder seals: Tighten loose fittings. Replace worn seals or fittings.

Piloted check valve or o-ring leak: Replace defective component.

5-4 HYDRAULIC PRESSURE TESTING

SET-UP: With the Loadoll unloaded, install a 0 to 3000 psi pressure gauge between the pump pressure hose and the valve "IN" port, using a "T" fitting and close pipe nipple.

TEST 1: Start the vehicle engine and operate the PTO. Do not run vehicle engine more than 1200 RPM. Check pressure without operating any function.

From 25 to 125 psi: NORMAL
Greater than 125 psi: Restriction in valve, filter, or plumbing
Less than 25 psi: Weak pump or restriction in pressure line.

NOTE: If STEP 1 indicates normal pressures, proceed to STEP 2. STEP 1 pressures must be normal for the following tests!

TEST 2: Run the bed forward to the transport position. Hold the valve in the "BED ON" position to cause hydraulic oil to go through the pressure relief valve. Read pressure, then return the control valve to neutral. Do the same test on the tilt cylinder, checking it while the bed is in the transport position.

From 1800 to 2500 psi: NORMAL
Greater than 2500 psi: Pressure relief valve is set too high.
 Pressure relief valve is malfunctioning.
Less than 1800 psi: *Internal cylinder leak.
 ** Pressure relief valve set too low.
 **Weak pump.

* This may be the problem if one cylinder is at the normal pressure and the other is at a lower pressure.

** This may be the problem if both cylinders show the same pressure.

TEST 3: Run the tilt cylinder until the bumper almost touches the ground. Return the cylinder to the transport position. Check pressures while the bed is tilting.

From 1000 to 2500 psi: NORMAL
Greater than 2500 psi: Restriction in return hoses or cylinder.
 Binding cylinder.
 Binding tilt mechanism.
Less than 1000 psi: Weak pump.
 Pressure hose restriction
 Internal cylinder leak.

TEST 4: Slide the bed cylinder back and then forward. Check pressures while the bed is moving out. The following pressures are with the bed installed.

From 300 to 900 psi: NORMAL
Greater than 900 psi: Restriction in return hoses or cylinder.
 Binding cylinder.
 Binding slide mechanism.
Less than 300 psi: Weak pump.
 Pressure hose restriction
 Internal cylinder leak.

TEST 5: Unhook the winch cable and lay it loosely on the bed. Operate the winch both directions. Check pressures while the winch is operating.

From 800 to 1200 psi: NORMAL
Greater than 1200 psi: Restriction in return hoses or winch motor.
 Binding winch motor.
 Binding winch gears or drum.
Less than 800 psi: Weak pump.
 Pressure hose restriction
 Internal motor leak.

5-5 MISCELLANEOUS PROBLEMS

BED CHATTERS OR SQUEALS
WHEN SLIDING

Rough slide tubes on subframe: file or sand smooth and lubricate with dry silicone or other non dirt and grit collecting lubricant.

VIBRATIONS WHILE DRIVING

Driveshaft out of balance, mis-aligned, or out of phase: correct problem and confirm u-joints are aligned correctly.
See Section 5-2 Tires-Wheels-Suspension

PIVOT PINS
EXCESSIVE WEAR

Not lubricated: grease pins at grease zerk.
Bent or broke subframe: check for bows or cracks in subframe.

PREMATURE BREAKAGE

Overweight loads and/or rough road conditions: check weight limitations and adjust driving style to road conditions.

BED SLIDE STRIPS EXCESSIVE
WEAR

Lubricated with heavy grease: remove grease and use dry silicone or other non dirt and grit collecting lubricant.
Rough slide tubes on subframe: smooth tubes.

NOTES:
