

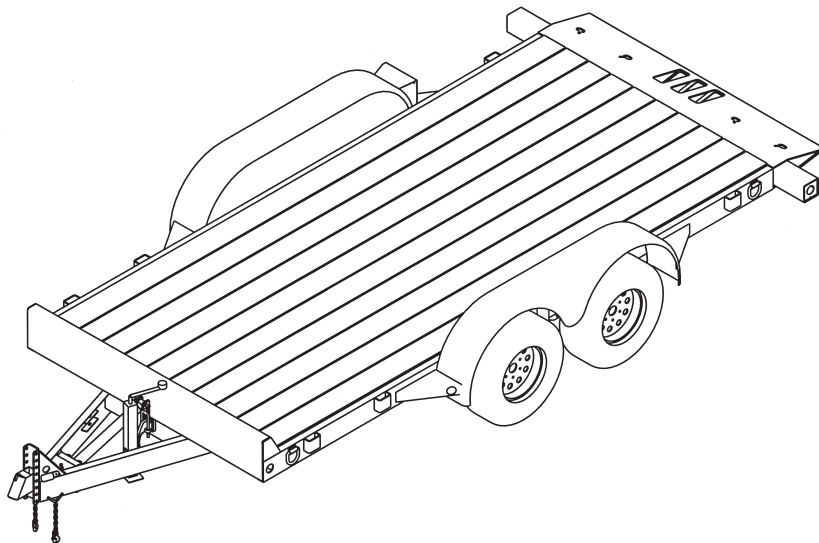

**MODEL LT08, LT10, LT12, AND LT14 SERIES  
TAG TRAILER  
OPERATOR'S MANUAL**



**1900 NORTH STREET  
MARYSVILLE, KANSAS 66508  
(785) 562-5381**





**MODEL LT08, LT10, LT12, AND LT14 SERIES  
TAG TRAILER  
OPERATOR'S MANUAL**

**PURCHASED FROM:** \_\_\_\_\_ **DATE** \_\_\_\_ / \_\_\_\_ / \_\_\_\_

**ADDRESS:** \_\_\_\_\_

\_\_\_\_\_

\_\_\_\_\_

**PHONE NO.:** \_\_\_\_\_ **SERIAL NO.:** \_\_\_\_\_

---



# TABLE OF CONTENTS

---

SECTION	DESCRIPTION	PAGE NO.
1	INTRODUCTION	
2	STANDARD SPECIFICATIONS	
3	OPERATING INSTRUCTIONS	
3-1	GENERAL . . . . .	3-1
3-2	PRE-COUPLING OF TRAILER AND TRUCK . . . . .	3-2
3-3	COUPLING OF THE TOWING VEHICLE TO THE TRAILER . . . . .	3-2
3-4	TOWING VEHICLE AND TRAILER HOOK-UP AND CHECK-OUT . . . . .	3-3
3-5	TOWING THE TRAILER . . . . .	3-4
3-6	PARKING THE TRAILER . . . . .	3-4
3-7	UNCOUPLING TOWING VEHICLE FROM TRAILER . . . . .	3-5
3-8	LOADING THE TRAILER . . . . .	3-5
3-9	UNLOADING THE TRAILER . . . . .	3-6
3-10	COLD WEATHER OPERATION . . . . .	3-6
3-11	HOT WEATHER OPERATION . . . . .	3-6
4	MAINTENANCE AND LUBRICATION	
4-1	GENERAL . . . . .	4-1
4-2	MAINTENANCE SCHEDULE . . . . .	4-1
4-3	MAINTENANCE PROCEDURES . . . . .	4-2
4-4	FRAME AND DECKS . . . . .	4-2
4-5	ELECTRICAL SYSTEM . . . . .	4-3
4-6	BRAKE SYSTEM MAINTENANCE . . . . .	4-3
4-7	HUB AND DRUM MAINTENANCE . . . . .	4-3
4-8	WHEEL BEARING . . . . .	4-3
4-9	SUSPENSION MAINTENANCE . . . . .	4-3
4-10	TIRES . . . . .	4-4
4-11	WHEELS . . . . .	4-4
4-12	HYDRAULIC CUSHION CYLINDER . . . . .	4-6
4-13	HYDRAULIC SYSTEM W/ FLOW CONTROL VALVE FILLING METHOD . . . . .	4-6
5	TROUBLESHOOTING	

# **REPORTING SAFETY DEFECTS**

---

If you believe that your vehicle has a defect which could cause a crash or could cause injury or death, you should immediately inform the National Highway Traffic Safety Administration (NHTSA) in addition to notifying Landoll Manufacturing.

If NHTSA receives similar complaints, it may open an investigation, and if it finds that a safety defect exists in a group of vehicles, it may order a recall and remedy campaign. However, NHTSA cannot become involved in individual problems between you, your dealer, or Landoll Manufacturing.

To contact NHTSA, you may either call the Auto Safety Hotline toll-free at 1-800-424-9393 (or 366-0123 in Washington, D.C. area) or write to: NHTSA, U.S. Department of Transportation, Washington, D.C. 20590. You can also obtain other information about motor vehicle safety from the Hotline.

In the event of a defect or problem with your LANDOLL equipment, please notify LANDOLL CORPORATION:

**LANDOLL CORPORATION  
SALES AND SERVICE  
1900 NORTH STREET  
MARYSVILLE, KANSAS 66508**

**OR PHONE:**

**1-800-HAULLOLL**

**(1-800-428-5655)**

**FAX NO.: (785)562-3240**

**FOR REPLACEMENT PARTS:**

**(785)562-4650**

**1-800-423-4320**

**FAX NO.: (785) 562-4654**

# SAFETY PRECAUTIONS

---



THIS IS THE SAFETY ALERT SYMBOL. IT IS USED TO ALERT YOU TO POTENTIAL INJURY HAZARDS. OBEY ALL SAFETY MESSAGES THAT FOLLOW THIS SYMBOL TO AVOID POSSIBLE INJURY OR DEATH.

## DANGER

DANGER INDICATES AN IMMINENTLY HAZARDOUS SITUATION WHICH, IF NOT AVOIDED, WILL RESULT IN DEATH OR SERIOUS INJURY.

## WARNING

WARNING INDICATES A POTENTIALLY HAZARDOUS SITUATION WHICH, IF NOT AVOIDED, COULD RESULT IN DEATH OR SERIOUS INJURY.

## CAUTION

CAUTION INDICATES A POTENTIALLY HAZARDOUS SITUATION WHICH, IF NOT AVOIDED, MAY RESULT IN MINOR OR MODERATE INJURY.

## CAUTION

CAUTION USED WITHOUT THE SAFETY ALERT SYMBOL INDICATES A POTENTIALLY HAZARDOUS SITUATION WHICH, IF NOT AVOIDED, MAY RESULT IN PROPERTY DAMAGE.



**IMPORTANT -  
HYDRAULIC SURGE BRAKE  
INFORMATION**

**TRAILERS EQUIPPED WITH HYDRAULIC SURGE BRAKES ARE ALLOWED WHEN THE TRAILER IS NOT SUBJECT TO THE FEDERAL MOTOR CARRIER SAFETY REGULATIONS (FMCSRs) OR EXCLUDED BY STATE REGULATION.**

This manual provides operating, servicing, and maintenance instructions, for Model LT08, LT10, LT12, and LT14 Series Tag Trailers, manufactured by Landoll Corporation, Marysville, Kansas 66508.

- SECTION 1** gives basic instructions on the use of this manual.
- SECTION 2** gives specifications for the trailer, including measurements and component specifications. A Standard Bolt Torque Table is provided to give guidelines for bolt torques to be used when servicing this product.
- SECTION 3** gives instructions for the proper operation of the equipment.
- SECTION 4** gives general maintenance procedures, a maintenance schedule, and a lubrication schedule. Improper maintenance will void your warranty.

**IF YOU HAVE ANY QUESTIONS CONTACT:**

**LANDOLL CORPORATION  
1900 NORTH STREET  
MARYSVILLE, KANSAS 66508  
or phone:  
(785) 562-5381 or  
(800) 428-5655  
or FAX:  
(785) 562-4893**

- SECTION 5** is a troubleshooting guide to aid in diagnosing and solving problems with the trailer.
- PARTS LIST** is a separate manual showing the various assemblies, subassemblies, and systems. Refer to that manual when ordering Landoll replacement parts. Order parts from your Landoll dealer.
- WARRANTY** The Warranty Registration form is located with the product documents. Fill it out and mail it within 15 days of purchase. The Warranty is printed inside the front cover.

**NOTE: IMPROPER ASSEMBLY, MODIFICATION, OR MAINTENANCE OF YOUR LANDOLL EQUIPMENT CAN VOID YOUR WARRANTY.**

- COMMENTS** Address comments or questions regarding this publication to:

**LANDOLL CORPORATION  
1900 NORTH STREET  
MARYSVILLE, KANSAS 66508  
ATTENTION: PUBLISHING -DEPT. 55**



# STANDARD SPECIFICATIONS

**CAPACITY (FRAME DESIGN):**

LT0816	7,000 LBS.
LT1016, LT1016-4, LT1020	10,000 LBS.
LT1216-4, LT1220	12,000 LBS.
LT1420	14,000 LBS.

**OVERALL WIDTH:** ..... 8'-6"

**WEIGHT:**

LT0816	2,600 LBS.
LT1016	3,150 LBS.
LT1016-4, LT1020	3,500 LBS.
LT1216-4, LT1220	3,700 LBS.
LT1420 W/ PINTLE HITCH	4,350 LBS.
LT1420 W/ GOOSENECK HITCH	5,520 LBS.

**HITCH:** ..... STD - 2-5/16" BALL HITCH OR 3" I.D. PINTLE EYE  
..... OPTION - GOOSENECK W/ 2-5/16" BALL HITCH

**DECK LENGTH:**

LT0816, LT1016	16' FLAT DECK
LT1016-4	16' TILT DECK + 4' STATIONARY
LT1020	20' TILT DECK
LT1216-4	16' TILT DECK + 4' STATIONARY
LT1220	20' TILT DECK
LT1420	20' TILT DECK

**LOAD ANGLE:**

LT0816, LT1016	12.4°
LT1016-4, LT1020, LT1216-4, LT1220	11.4°
LT1420	12.1°

**SPECIFIC BOLT TORQUES:**

12" X 2" ELECTRIC BRAKE MOUNTING NUT	30 - 35 FT. LBS.
12-1/4" X 3-3/8" ELECTRIC BRAKE MOUNTING NUT	75 - 85 FT. LBS.
1/2" DIAMETER WHEEL NUTS	90 - 120 FT. LBS.
5/8" DIAMETER WHEEL NUTS	275 - 325 FT. LBS.

**NOTE:** FOR GENERAL TORQUE SPECIFICATIONS, REFER TO TABLE 2-1.

**LANDOLL CORPORATION  
GENERAL TORQUE SPECIFICATIONS (REV. 4/97)**

THIS CHART PROVIDES TIGHTENING TORQUES FOR GENERAL PURPOSE APPLICATIONS WHEN SPECIAL TORQUES ARE NOT SPECIFIED ON PROCESS OR DRAWING.

ASSEMBLY TORQUES APPLY TO PLATED NUTS AND CAPSCREWS ASSEMBLED WITHOUT SUPPLEMENTAL LUBRICATION (AS RECEIVED CONDITION). THEY DO NOT APPLY IF SPECIAL GRAPHITE MOLY-DISULFIDE OR OTHER EXTREME PRESSURE LUBRICANTS ARE USED.

WHEN FASTENERS ARE DRY (SOLVENT CLEANED), ADD 33% TO AS RECEIVED CONDITION TORQUE.

BOLT HEAD IDENTIFICATION MARKS INDICATE GRADE AND MAY VARY FROM MANUFACTURER TO MANUFACTURER.

THICK NUTS MUST BE USED ON GRADE 8 CAPSCREWS.

USE VALUE IN [ ] IF USING PREVAILING TORQUE NUTS.

**TORQUE IS SPECIFIED IN FOOT POUNDS**

UNC Size	SAE Grade 2		SAE Grade 5		SAE Grade 8		UNF Size	SAE Grade 2		SAE Grade 5		SAE Grade 8	
1/4-20	4	[5]	6	[7]	9	[11]	1/4-28	5	[6]	7	[9]	10	[12]
5/16-18	8	[10]	13	[16]	18	[22]	5/16-24	9	[11]	14	[17]	20	[25]
3/8-16	15	[19]	23	[29]	35	[43]	3/8-24	17	[21]	25	[31]	35	[44]
7/16-14	24	[30]	35	[43]	55	[62]	7/16-20	27	[34]	40	[50]	60	[75]
1/2-13	35	[43]	55	[62]	80	[100]	1/2-20	40	[50]	65	[81]	90	[112]
9/16-12	55	[62]	80	[100]	110	[137]	9/16-18	60	[75]	90	[112]	130	[162]
5/8-11	75	[94]	110	[137]	170	[212]	5/8-18	85	[106]	130	[162]	180	[225]
3/4-10	130	[162]	200	[250]	280	[350]	3/4-16	150	[188]	220	[275]	320	[400]
7/8-9	125	[156]	320	[400]	460	[575]	7/8-14	140	[175]	360	[450]	500	[625]
1-8	190	[237]	408	[506]	680	[850]	1-14	210	[263]	540	[675]	760	[950]
1-1/8-7	270	[337]	600	[750]	960	[1200]	1-1/8-12	300	[375]	660	[825]	1080	[1350]
1-1/4-7	380	[475]	840	[1050]	1426	[1782]	1-1/4-12	420	[525]	920	[1150]	1500	[1875]
1-3/8-6	490	[612]	110	[1375]	1780	[2225]	1-3/8-12	560	[700]	1260	[1575]	2010	[2512]
1-1/2-6	650	[812]	1460	[1825]	2360	[2950]	1-1/2-12	730	[912]	1640	[2050]	2660	[3325]

**METRIC**

COARSE THREAD METRIC CLASS 10.9 FASTENERS AND CLASS 10.0 NUTS AND THROUGH HARDENED FLAT WASHERS, PHOSPHATE COATED, ROCKWELL "C" 38-45.

USE VALUE IN [ ] IF USING PREVAILING TORQUE NUTS.

Nominal Thread Diameter mm	Standard Torque		Nominal Thread Diameter mm	Standard Torque					
	Newton-Meters	Foot-Pounds		Newton-Meters	Foot-Pounds				
6	10	[14]	7	[10]	20	385	[450]	290	[335]
7	16	[22]	12	[16]	24	670	[775]	500	[625]
8	23	[32]	17	[24]	27	980	[1105]	730	[825]
10	46	[60]	34	[47]	30	1330	[1470]	990	[1090]
12	80	[101]	60	[75]	33	1790	[1950]	1340	[1450]
14	125	[155]	90	[115]	36	2325	[2515]	1730	[1870]
16	200	[240]	150	[180]	39	3010	[3210]	2240	[2380]
18	275	[330]	205	[245]					

**Table 2-1 General Torque Specifications**

**LANDOLL CORPORATION  
HYDRAULIC FITTING TORQUE SPECIFICATIONS  
37° JIC, ORS, & ORB (REV. 10/97)**

THIS CHART PROVIDES TIGHTENING TORQUES FOR HYDRAULIC FITTING APPLICATIONS WHEN SPECIAL TORQUES ARE NOT SPECIFIED ON PROCESS OR DRAWING.

ASSEMBLY TORQUES APPLY TO PLATED CARBON STEEL AND STAINLESS STEEL FITTINGS ASSEMBLED WITHOUT SUPPLEMENTAL LUBRICATION (AS RECEIVED CONDITION). THEY DO NOT APPLY IF SPECIAL GRAPHITE MOLY-DISULFIDE OR OTHER EXTREME PRESSURE LUBRICANTS ARE USED.

BRASS FITTINGS AND ADAPTERS - 65% OF THE TORQUE VALUE FOR STEEL. STAINLESS STEEL, ALUMINUM AND MONEL - THREADS ARE TO BE LUBRICATED.

**TORQUE IS SPECIFIED IN FOOT POUNDS**

**PARKER BRAND FITTINGS**

<b>Dash Size</b>	<b>37 Degree JIC</b>	<b>O-Ring (ORS)</b>	<b>O-Ring Boss (ORB)</b>
-4	11-13	15-17	13-15
-5	14-16	—	21-23
-6	20-22	34-36	25-29
-8	43-47	58-62	40-44
-10	55-65	100-110	57.5-62.5
-12	80-90	134-146	75-85
-16	115-125	202-218	109-121
-20	160-180	248-272	213-237
-24	185-215	303-327	238-262
-32	250-290	—	310-340

**LANDOLL CORPORATION  
HYDRAULIC FITTING TORQUE SPECIFICATIONS  
37° JIC, ORS & ORB (REV. 10/97)**

THIS CHART PROVIDES TIGHTENING TORQUES FOR HYDRAULIC FITTING APPLICATIONS WHEN SPECIAL TORQUES ARE NOT SPECIFIED ON PROCESS OR DRAWING.

ASSEMBLY TORQUES APPLY TO PLATED CARBON STEEL AND STAINLESS STEEL FITTINGS ASSEMBLED WITHOUT SUPPLEMENTAL LUBRICATION (AS RECEIVED CONDITION). THEY DO NOT APPLY IF SPECIAL GRAPHITE MOLY-DISULFIDE OR OTHER EXTREME PRESSURE LUBRICANTS ARE USED.

BRASS FITTINGS AND ADAPTERS - 65% OF THE TORQUE VALUE FOR STEEL.

**TORQUE IS SPECIFIED IN FOOT POUNDS.**

**AEROQUIP BRAND FITTINGS**

<b>Dash Size</b>	<b>37 Degree JIC</b>	<b>O-Ring (ORS)</b>	<b>O-Ring Boss (ORB)</b>
-4	11-12	10-12	14-16
-5	15-16	—	18-20
-6	18-20	18-20	24-26
-8	38-42	32-35	50-60
-10	57-62	46-50	72-80
-12	79-87	65-70	125-135
-14	—	—	160-180
-16	108-113	92-100	200-220
-20	127-133	125-140	210-280
-24	158-167	150-165	270-360
-32	245-258	—	—

**Table 2-2 Hydraulic Fitting Torque Specifications**



## 3-1 GENERAL

This section supplies information for operation of the trailer. It describes and locates controls, and gives general operation procedures. Read all instructions, warnings, cautions, and danger notes before attempting to operate the trailer. Operators must have proper training before operating the trailer.

### IMPORTANT

**THE TRAILER IS WIRED ACCORDING TO FIGURE 3-1. BE SURE THE TRUCK ELECTRICAL MATCHES TO ELIMINATE ANY POTENTIAL ELECTRICAL PROBLEMS.**

### WARNING

**DO NOT OPERATE THE TRAILER WITH ANY KNOWN FAULT THAT MIGHT ENDANGER THE OCCUPANTS, NEARBY WORKERS, OTHER TRAFFIC, THE LOAD, OR THE EQUIPMENT.**

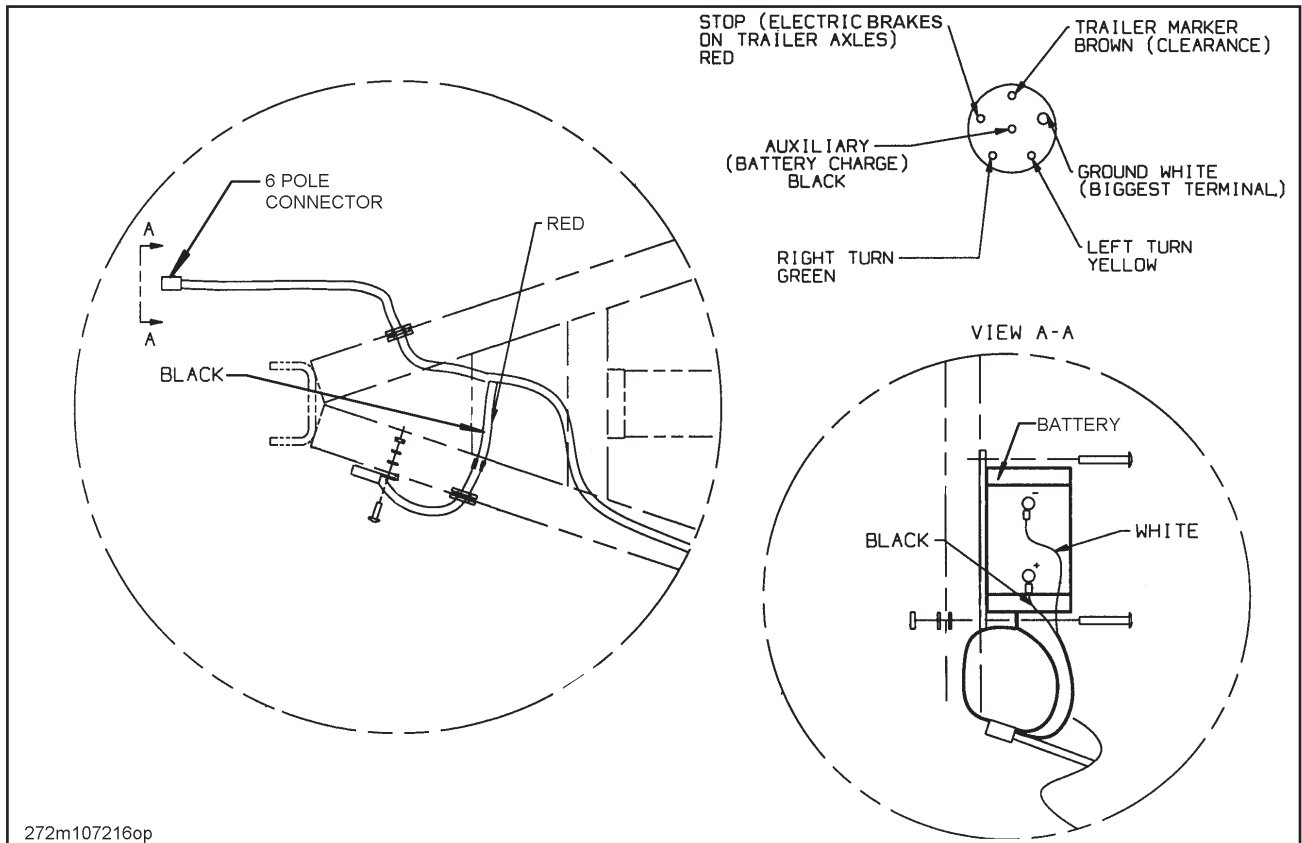

Figure 3-1 Electrical Diagram

## 3-2 PRE-COUPLING OF TRAILER AND TRUCK

---

- 3-2.1** Slowly back the truck (towing vehicle) up to the front end of the trailer so the hitch of the trailer is centered with the truck. Stop the towing vehicle just inches ahead of the trailer. Set truck parking brake.
- 3-2.2** The hitch on the trailer can be adjusted to different heights. Make sure the hitch height is at the correct height so the trailer deck is about parallel to the ground when loaded.

- 3-2.3** If the trailer hitch needs some adjustment to connect to the truck, manually raise or lower the front of trailer by cranking the landing gear (parking stands) up or down until the proper height has been obtained.
- 3-2.4** Connect electrical receptacle to the truck.
- 3-2.5** Apply brakes and inspect brake action on all wheels for prompt application.

## 3-3 COUPLING OF THE TOWING VEHICLE TO THE TRAILER

---

### **DANGER**

**KEEP ALL PERSONNEL CLEAR OF FRONT, REAR, AND SIDES OF TOWING VEHICLE AND TRAILER DURING COUPLING, COMPONENT OPERATIONS, AND UNCOUPLING. FAILURE TO STAY CLEAR CAN RESULT IN SERIOUS PERSONAL INJURY OR DEATH.**

- 3-3.1** Verify the trailer wheels are chocked and brakes function properly.
- 3-3.2** Make sure the towing vehicle's coupler is open.

### **CAUTION**

**PUSHING THE TRAILER BACKWARDS CAN DAMAGE LANDING GEAR.**

- 3-3.3** Slowly back the towing vehicle so the hitch contacts the trailer hitch. Make sure the hitch is centered and will properly connect up. Set the vehicle brakes.
- 3-3.4** Raise the landing gear (parking stands) and lock the hitch in place.

### **IMPORTANT**

**KEEP BRAKES ENGAGED FOR REMAINDER OF HOOKUP, CHECK-OUT PROCEDURES, AND FOR PARKING.**

### 3-4 TOWING VEHICLE AND TRAILER HOOK-UP AND CHECK-OUT

---

#### **WARNING**

**FAILURE TO PROPERLY SET AND CHECK PARKING BRAKE, AND CHOCK WHEELS WHEN PARKING AND DURING STORAGE, COULD ALLOW MOVEMENT OF THE TRUCK/TRAILER RESULTING IN SERIOUS PERSONAL INJURY, DEATH, OR DAMAGE TO PROPERTY IN ITS PATH.**

- 3-4.1** Connect the electrical receptacle on the front of the trailer to the towing vehicle.

#### **IMPORTANT**

**THE KEY ON THE PLUG AND THE KEYWAY IN THE SOCKET MUST BE PROPERLY ALIGNED BEFORE INSERTING THE PLUG INTO THE TRAILER SOCKET.**

- 3-4.2** Assure landing gear is raised up all the way.
- 3-4.3** Attach safety chains from the trailer to the towing vehicle.
- 3-4.4** For electric brake breakaway system, attach brake breakaway cable to towing vehicle. Allow slack in cable for turning. Make sure breakaway battery is charged and breakaway system is working properly.

#### **WARNING**

**MAKE SURE ELECTRIC AND SURGE BRAKE BREAKAWAY CABLE IS CONNECTED FOR PROTECTION WHILE TRAVELING. FAILURE OF CABLE CONNECTION WILL CONSTITUTE NO EMERGENCY BRAKING SYSTEM IN THE EVENT THAT THE TRAILER IS SEPARATED FROM THE TOWING VEHICLE. THIS MAY RESULT IN SERIOUS PERSONAL INJURY, DEATH, OR DAMAGE TO PROPERTY.**

- 3-4.5** For trailers with surge brakes, connect breakaway chain s-hook to towing vehicle. Allow slack for turning, but avoid letting chain drag on pavement. Provide as straight a connection as possible.
- 3-4.6** For trailers with surge brakes, sway control devices that restrict operation of the actuator cannot be used. The actuator must be free to telescope in response to braking requirements.
- 3-4.7** Check your maintenance schedule and be sure everything is up-to-date.
- 3-4.8** Set parking brake and carefully remove all wheel chocks. If brakes are not properly set, the truck/trailer may roll when removing wheel chocks.

## 3-5 TOWING THE TRAILER

---

- 3-5.1** Driving the towing vehicle with the trailer coupled behind requires constant attention to the overall length of the combination. Turning, passing, acceleration, braking, stopping, and back-up require special attention to the “hinged-in-the-middle” configuration of the trailer. When executing steep grades or turning tight curves, the trailer must not be allowed to push the towing vehicle, or jackknifing the trailer with the towing vehicle may result. Application of the trailer brakes to keep the trailer in tow will help prevent this pushing. Braking should begin before descending a hill or attempting a curve, to assure control.
- 3-5.2** Make a moving test of the trailer brakes at low, and medium speeds *before* traveling at highway speed.
- 3-5.3** The trailer wheels track to the inside of the towing vehicle during turns. Thus, turning corners requires a wide swing to prevent “curb hopping”, and to allow the trailer wheels to clear any obstacle on the inside of the corner.
- 3-5.4** To stop, use a gradual and smooth application of brakes. If grabbing occurs, apply less pressure. Grabbing brakes are not efficient.
- 3-5.5** During any extended stop period, use wheel chocks to secure the vehicle from moving.

## 3-6 PARKING THE TRAILER

---

- 3-6.1** Position truck/trailer on a level, solid surface.

### DANGER

**ALWAYS CHECK BEHIND AND UNDER THE TRUCK AND TRAILER FOR PERSONS OR OBJECTS BEFORE MOVING. FAILURE TO CHECK CAN LEAD TO SERIOUS PERSONAL INJURY OR DEATH TO OTHERS, OR DAMAGE TO PROPERTY.**

- 3-5.6** Backing should be done with care. Tail overhang, trailer length, and allowable space must be taken into consideration. For trailers with surge brakes, backing up a steep incline or backing up fast can cause the actuator to apply the brakes. The brakes cannot be expected to hold the trailer without pressure on the hitch to activate the actuator.
- 3-5.7** The load on the trailer should be positioned so a minimum of 8% of the total weight is on all the LT series trailers. The maximum of the total weight on the hitch for the LT8 and LT10 series shall be 30%. The maximum of the total weight on the hitch of the LT12 and LT14 series shall be 25%.

### IMPORTANT

**ELECTRIC BRAKE AND SURGE BRAKE TRAILERS DO NOT HAVE A PARKING BRAKE.**

- 3-6.2** Chock wheels of trailer.

## 3-7 UNCOUPLING TOWING VEHICLE FROM TRAILER

---

- 3-7.1 Park the trailer according to instructions in **Section 3-6**.
- 3-7.2 Lower the landing gear to the ground using the manual crank on the trailer.
- 3-7.3 With electric brake trailers, disconnect the brake breakaway cable. Disconnect the electrical cable and store so end is not on the ground.
- 3-7.4 With surge brake trailers, disconnect the breakaway chain. Disconnect the electrical cable and store so end is not on the ground.
- 3-7.5 Disconnect safety chains from the towing vehicle.
- 3-7.6 Verify that all service lines are disconnected and trailer wheels are chocked.
- 3-7.7 Unlock hitch and raise trailer hitch by cranking landing gear down until the hitch is in a position to be disconnected.
- 3-7.8 Pull towing vehicle away from the trailer.

## 3-8 LOADING THE TRAILER

---

- 3-8.1 Practice all standard industrial safety standards. Do not load any payload that will overload any component of the trailer or cause an unsafe condition.
- 3-8.6 Slowly drive the load onto the trailer until the center of gravity of the load is just slightly in front of the pivot point of the bed and stop until the bed slowly lowers down to the transport position. After the bed has completely lowered, then drive the load on forward until the load center of gravity is centered from side to side and so between 8% and 25% of the total weight of trailer plus payload is on the hitch.

 **WARNING**

**DO NOT ATTEMPT TO LOAD OR UNLOAD TRAILER WITHOUT CHECKING TO MAKE SURE NOTHING IS IN THE WAY WHEN THE BED IS TILTED. PROPERTY DAMAGE, PERSONAL INJURY OR DEATH IS POSSIBLE IF IN THE PATH OF THE TILTING BED.**

- 3-8.2 Assure maintenance schedule is up-to-date and trailer is ready to be pulled.
- 3-8.3 Park towing vehicle and trailer on relatively level ground.
- 3-8.4 Unlock the over-center hold-down latch located at the front of the bed. Swing the latch u-bolt forward far enough that it will clear the bed anchor.
- 3-8.5 Keeping feet from under trailer where they can become pinched, step on the back of the trailer until the back of trailer rests firmly on the ground.
- 3-8.7 Some of the trailers have a load holding valve on them. When the valve knob is screwed shut, it will keep the trailer deck in the tilted position once it is tilted. This feature will allow the trailer to be loaded and stay tilted even if the load center of gravity goes past the pivot point. When the load center of gravity is secured in front of the pivot point, the load holding valve knob can be slowly opened to allow the bed to tilt slowly down into road position.
- 3-8.8 Secure the load using approved standard tie-down methods.
- 3-8.9 Lock the bed down with the over-center hold-down latch located at the front of the bed.

### **IMPORTANT**

**THIS VALVE DOES NOT KEEP BED FROM TILTING UP EVEN WHEN SHUT OFF.**

## 3-9 UNLOADING THE TRAILER

---

**3-9.1** Practice all standard industrial safety standards.

 **WARNING**

**DO NOT ATTEMPT TO LOAD OR UNLOAD TRAILER WITHOUT CHECKING TO MAKE SURE NOTHING IS IN THE WAY WHEN THE BED IS TILTED. PROPERTY DAMAGE, PERSONAL INJURY OR DEATH IS POSSIBLE IF IN THE PATH OF THE TILTING BED.**

**3-9.2** Park towing vehicle and trailer on relatively level ground.

**3-9.3** Set towing vehicle's brakes.

**3-9.4** Unlock the over-center hold-down latch located at the front of the bed. Swing the latch u-bolt forward far enough that it will clear the bed anchor.

**3-9.5** Making sure the payload will not roll in any direction, remove the payload tie-downs. Make sure nothing is in the path of the tilting bed.

**3-9.6** Slowly drive the load back until the center of gravity is just slightly back of the pivot point of the bed and stop until the bed slowly lowers down to the ground. After the bed has completely tilted down to the ground, drive the load off the trailer far enough that the bed will not hit it when tilted back down.

**3-9.7** Lower the bed back down to the transport position by walking up the bed far enough that the bed tilts back down.

**3-9.8** Lock the bed down with the over-center hold-down latch located at the front of the bed.

## 3-10 COLD WEATHER OPERATION

---

**3-10.1** Cold weather causes lubricants to congeal, insulation and rubber parts to become hard, which may lead to problems found in bearings and electrical systems. Moisture attracted by warm parts can condense, collect and freeze to immobilize equipment. The truck/trailer operator must always be alert for indicators of cold weather malfunctions.

**3-10.2** Check all structural fasteners, gaskets, seals and bearings for looseness that can develop due to contraction with cold. Do not over-tighten.

**3-10.3** Check tire inflation. Tire inflation decreases when the temperature decreases.

## 3-11 HOT WEATHER OPERATION

---

**3-11.1** Hot weather operation can cause expansion of parts, resulting in tightening of bearings, fasteners, and moving parts. Failure of gaskets or seals can occur.

**3-11.2** The trailer should be parked in the shade if possible. Long exposure to the sun will shorten service life of rubber components (i.e., tires, light and hose grommets, hoses, etc.) and paint life.

**3-11.3** Check tire pressure early in the day before beginning operations while the tire is cool. Put all valve stem caps back on after checking.

**3-11.4** If the area is extremely humid, protect electrical terminals with ignition insulation spray. Coat paint and bare metal surfaces with an appropriate protective sealer.

## 4-1 GENERAL

This section contains instructions necessary for proper maintenance of the trailer. The trailer is designed for years of service with minimal maintenance. However, proper maintenance is important for durability and safe operation and is an owner/user responsibility.

## 4-2 MAINTENANCE SCHEDULE

Trailer maintenance includes periodic inspection and lubrication. **Table 4-2, Maintenance Schedule**, lists the recommended maintenance and lubrication tasks by time interval and by accumulated mileage (use whichever occurs first).

### 4-2.1 Inspection

 <b>DANGER</b>
<b>OPERATING THE TRUCK OR TRAILER WITH DEFECTIVE, BROKEN OR MISSING PARTS MAY RESULT IN SERIOUS INJURY OR DEATH; DAMAGE TO THE TRUCK/TRAILER, ITS CARGO, OR PROPERTY IN ITS PATH.</b>

Inspect the towing vehicle, the trailer, and trailer parts periodically for damage or signs of pending failure. Damaged or broken parts must be repaired or replaced at once. Determine the cause of any binding, at once. Correct the problem before using the towing vehicle or trailer.

**4-2.2 Lubrication.** See **Table 4-1** for lubricant required for axles. During inspections of the trailer, if lubricants are found to be fouled with dirt or sand, those parts should be cleaned with solvent, dried, and relubricated immediately. Dirt in a lubricant forms an abrasive compound that will wear parts rapidly.

 <b>WARNING</b>
<b>PAINT THINNER AND OTHER SOLVENTS ARE FLAMMABLE AND TOXIC TO THE EYES, THE SKIN, AND THE RESPIRATORY TRACT. AVOID SKIN AND EYE CONTACT. GOOD GENERAL VENTILATION IS NORMALLY ADEQUATE. KEEP AWAY FROM OPEN FLAMES OR OTHER COMBUSTIBLE ITEMS.</b>

## 4-3 MAINTENANCE PROCEDURES

---

**4-3.1 Repair Parts.** Repair parts are illustrated and listed in the parts manual. Replacement of parts due to wear is determined by examination and measurement.

**4-3.2 Tools and Equipment.** Tools, equipment, and personnel normally found in a facility capable of making truck repairs will be adequate for maintenance of the trailer. No other special tools or equipment should be necessary.

**4-3.3 Standard Torque Values. Tables 2-1 and 2-2** list torque values for standard hardware and is intended as a guide for average applications involving typical stresses and mechanical surfaces. Values are based on the physical limitations of clean, plated, and lubricated hardware. In all cases, when an individual torque value is specified, it takes priority over values given in this table. Replace original fasteners with hardware of equal grade.

### 4-3.4 Cleaning

- a. Wash trailer to remove all accumulated dirt and grime.
- b. Use any mineral spirits paint thinner (or its equivalent) to remove grease and oil from all parts of the trailer. Rinse degreasing solution off with cold water.
- c. Inspect trailer for cause of any reported troubles.
- d. Scrape, sand, prime, and repaint areas where finish is missing or where there is evidence of corrosion.
- e. Replace any missing or illegible decals. Replace any missing or damaged reflective tape.
- f. Use the Troubleshooting Guide to check for "SYMPTOMS" and "PROBLEMS" of any trailer system not functioning correctly. Administer "REMEDY" according to the right-hand column of the Troubleshooting guide.
- g. After disassembling any components, thoroughly clean dirt and old lubricant from all parts. Do not use a wire brush on any bearing parts or surfaces — use a stiff bristle brush. Do not use compressed air, or spin bearing parts when cleaning. These practices can throw solvents, dirt, or metal particles into your eyes. Dry clean parts with lint free, clean, soft, absorbent, cloth or paper. Wash and dry hands.
- h. Inspect seals, seal wiping surfaces, any bearing caps, and bearing cones for wear, pitting, chipping, or other damage.

## 4-4 FRAME AND DECKS

---

The trailer should be thoroughly checked daily for cracks or material fatigue. Cracks will normally show best under loaded conditions. If any cracks or breaks are found, immediately contact Landoll Corporation for recommended repair. Any defective parts must be replaced immediately.

## **4-5 ELECTRICAL SYSTEM**

---

**4-5.1** Maintenance of the electrical system consists of inspection and minor servicing. Any wire, connection or electrical component showing signs of corrosion, wear, breakage or unraveling must be repaired or replaced.

**4-5.2** Frayed or unraveling wire must have the defective section removed and replaced with wire of the same color and gauge. Seal all connections and insulate.

**4-5.3** Corroded terminals must have the corrosion removed, source of corrosion neutralized and the terminals resealed, protected and insulated.

**4-5.4** Fuse or circuit breaker burn-out or “blow-out” usually indicates an electrical short-circuit, although a fuse can occasionally fail from vibration. Insert a second fuse or reset the breaker. If this fuse immediately burns out or the breaker trips, locate the cause of the electrical short and repair.

**4-5.5** Lights with a repeated lamp burn-out usually indicates a loose connection, poor system ground, or a malfunctioning voltage regulator. Locate the source of the problem and repair. System grounds must be grounded to bare metal surfaces. Paint, grease, wax, and other coatings act as insulators. Replacement lamps must be equivalent to the factory installed lamp.

## **4-6 BRAKE SYSTEM MAINTENANCE**

---

Follow operation maintenance service manual from brake and axle manufacturer. If another manual is required, it may be obtained by requesting Landoll p/n 107482.

## **4-7 HUB AND DRUM MAINTENANCE**

---

Follow operation, maintenance, service manual from hub and drum vendor that comes with each trailer. If another manual is required, it can be obtained by requesting Landoll p/n 107482.

## **4-8 WHEEL BEARING**

---

Use vendor manual for electric or hydraulic brake parts and recommendations. If another manual is required, it can be obtained by requesting Landoll p/n 107482.

## **4-9 SUSPENSION MAINTENANCE**

---

Use vendor manual for suspension parts and recommendations. If another manual is required, it can be obtained by requesting Landoll p/n 107482.

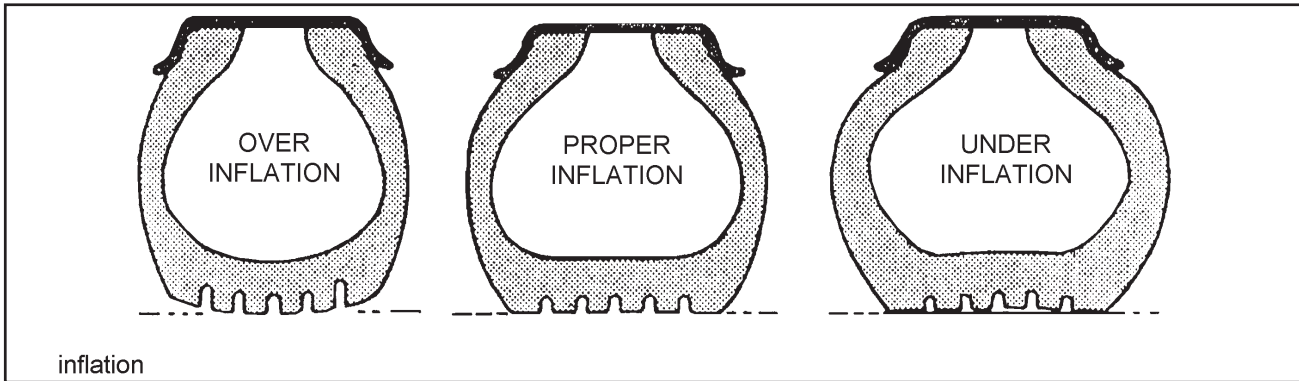

Figure 4-1 Tire Inflation Examples

## 4-10 TIRES

**4-10.1 Tire Inflation.** Tire inflation will cause tire to ground contact characteristics as shown in **Figure 4-1**. Tire inflation should be checked daily while the tire is cold, and during road stops. Checking the tire pressures while tires are hot will give a faulty increased pressure reading. Adjusting tire air pressure to the specified amount while tires are hot will produce improper tire to road contact and

thus abnormal wear. Do not exceed cold inflation pressure listed on the trailer VIN plate. Exceeding cold inflation pressure will result in damaged tire bodies, rims, and wheels. Replace all valve stem caps when pressure checking/adjusting has been completed.

## 4-11 WHEELS

Use vendor manual for wheels and recommendations. If another manual is required, it can be obtained by requesting Landoll p/n 107482.

APPROVED SOURCES by BRAND AND PRODUCT (WEIGHT AND/OR TYPE)	
Mobil Oil	Mobilgrease HP
Exxon/Standard	Ronex MP
Kendall Refining Co.	Kendall L-427
Ashland Oil Co.	Valvoline Val-plex EP Grease
Pennzoil Prod. Co.	Premium Wheel Bearing Grease 707L

Table 4-1 Lubrication Specifications

NORMAL OPERATING SERVICE INTERVALS <sup>a</sup>								
SERVICE INTERVAL : ITEM	TIMES	Before Every Use	1st 5 Hrs	Weekly	Monthly	6 Months	Yearly	NOTES
	MILES		50	500	2,000	12,000	25,000	
LIGHTS			I	I				
WIRING & CONNECTIONS			I		I			
FASTENERS			I, T		I			b
BRAKE ADJ & WEAR					I, T			d
WHEEL BEARINGS						I, T, L		c
TIRE INFLATION & WEAR				I				e
WHEEL LUG NUTS			I, T	I	I, T			f
BATTERY & BREAKAWAY FOR ELECTRIC BRAKES				I				
HYDRAULIC CUSHION CYLINDER OIL							R	g
ROLLERS IN SURGE BRAKE HITCH					L			c
BRAKE FLUID RESERVOIR IN SURGE BRAKE		I						h
<b>I – Inspect, R – Replace, T– Tighten/ Adjust Torque, L – Lubricate, C – Clean</b>								
NOTES:								
a. Perform at the time shown. Shorten service intervals when operating in severe or dirty conditions.								
b. See <b>Tables 2-1 and 2-2</b> for correct torque.								
c. Use lubricant per <b>Table 4-1</b> .								
d. Call Landoll Customer Services or consult axle manual for procedures to replace.								
e. See Serial Number Plate on the front of the semitrailer for proper inflation requirements.								
f. See axle manual for stud tightening sequence.								
g. See <b>Table 4-3</b> for hydraulic oil.								
h. Reservoir must be at least half full to within 3/8" below top of the reservoir with DOT 3 brake fluid.								

**Table 4-2 Maintenance Schedule**

SEASON	BRAND AND PRODUCT (WEIGHT AND/OR TYPE)			
	MOBIL	EXXON	PHILLIPS	TEXACO
ALL YEAR	DTE-13	HDX Plus 10W	Mangus Oil A KV 5W-20	Rando HD-AZ

**Table 4-3 Approved Sources for Hydraulic Oil**

## 4-12 HYDRAULIC CUSHION CYLINDER

---

- 4-12.1** Maintenance of the hydraulic cushion cylinder consists of replacing hydraulic oil according to maintenance schedule.
- 4-12.2** Check troubleshooting section if hydraulic cushion cylinder is not operating.

- 4-12.3** The amount of hydraulic oil required is about one quart. With the hydraulic cylinder all the way retracted, the hydraulic cylinder, hydraulic hose, and hydraulic fittings should be completely full of oil before putting the plug into the tee.
- 4-12.4** If the unit has the flow control valve on it, the system will require about a gallon of oil. All the air has to be out of the system for the flow control valve to work correctly (**See Section 4-13**).

## 4-13 HYDRAULIC SYSTEM W/ FLOW CONTROL VALVE FILLING METHOD

---

**4-13.1** Make sure flow control valve and diaphragm reservoir are plumbed correctly (**See Figure 4-2**). Open flow control valve. With cylinder retracted, connect a hydraulic tank that can be pressurized to tee at butt end of cylinder. Crack open fitting at diaphragm reservoir to let air out. Apply air pressure to hydraulic tank to force hydraulic oil through the hoses. When oil starts coming out of fitting at diaphragm reservoir, crack open fitting at rod end of cylinder and slowly extend rod of cylinder. When oil starts coming out fitting at cylinder close fitting at diaphragm reservoir and crack open other fittings at flow control valve to get air out of them. Allow oil to come out of them for a half minute, then close all fittings.

- 4-13.2** Shut off air pressure to hydraulic tank and remove fill cap. Retract rod of cylinder. Make sure tank has plenty of oil. Install fill cap and apply air pressure again. Crack open fitting at diaphragm reservoir and extend cylinder rod slowly. Allow oil to come out fitting at least a couple minutes and longer if air keeps coming out. When air stops coming out, close that fitting and open other fittings at flow control valve to assure no air is at them. Close them and crack open fitting at rod end of cylinder and allow oil to come out for a couple minutes or until no air comes out with the oil. To assure all air gets out, repeat this step.
- 4-13.3** Shut off air pressure to hydraulic tank and remove fill cap. Retract cylinder rod 6" (It should be extended 10"). Disconnect hydraulic tank at tee and plug tee. Connect cylinder to bed. Shut flow control valve. The bed should tilt up, but not come back down more than an inch. Open the flow control valve and the bed should come down slowly.
- 4-13.4** If the system does not work properly, check the following:
- Make sure flow control valve is installed as shown in **Figure 4-2**.
  - Make sure hoses go to correct locations as shown in **Figure 4-2**.
  - Make sure diaphragm reservoir does not have a plug in end that would not let air go freely in and out of bladder.
  - Repeat **Steps 4-13.1 - 4-13.3** to remove air from hydraulic system.
  - Replace flow control valve.

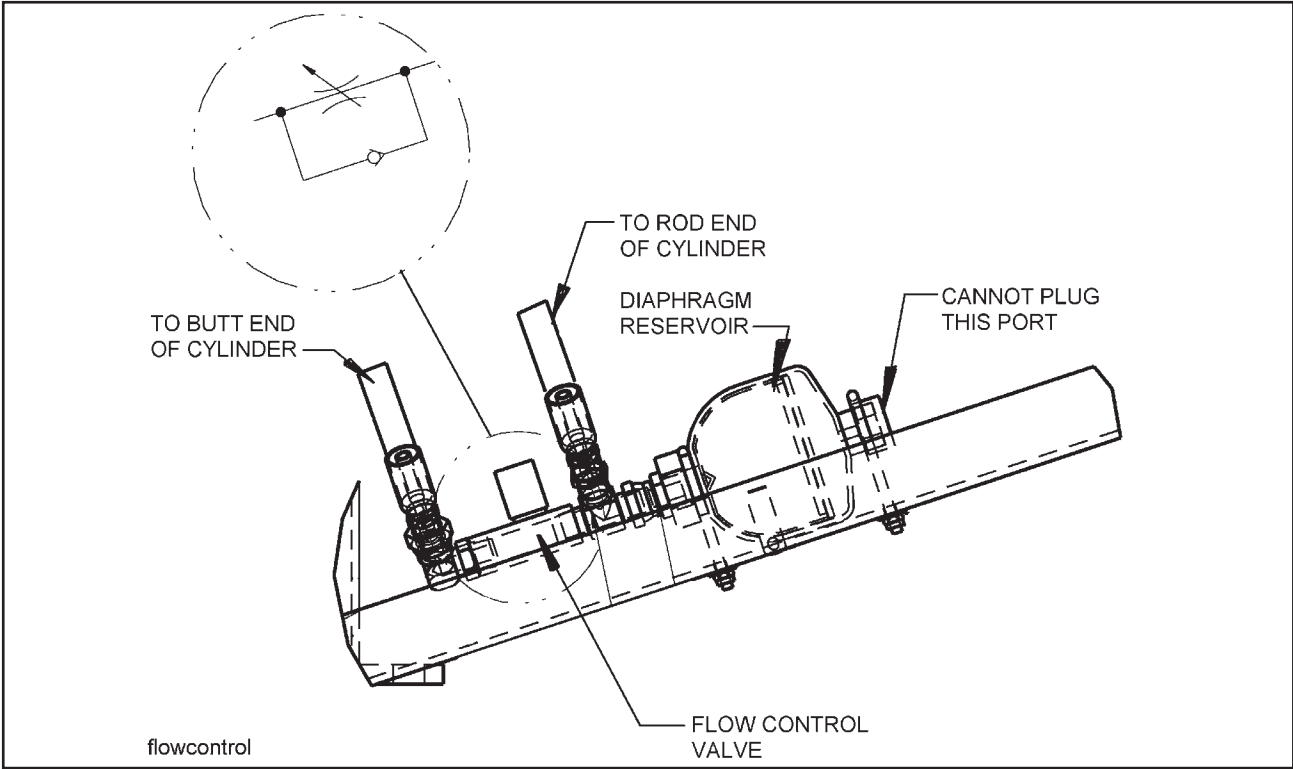

**Figure 4-2 Flow Control Valve Installation**

**NOTES:**

---

Troubleshooting should be performed by a trained and competent technician. Landoll Corporation is not responsible for equipment that is improperly maintained. Contact an authorized Landoll dealer or the Landoll Service department for service questions.

## 5-1 ELECTRICAL

Most electrical system problems show up as a burned out light or fuse, or inoperative electrical component. Wiring, grounds or components may be at fault. Locate the symptom in this section that best identifies your electrical problem. Check out each possible problem under that symptom. If the problem cannot be located, see an automotive electrical specialist. For maintenance procedures, **see Section 4-5.**

<b>SYMPTOM</b>	<b>PROBLEM: REMEDY</b>
NO LIGHTS	<b>Fuse blown on tractor:</b> Replace fuse. <b>Loose connection at plug-in:</b> Tighten connection. <b>Broken or corroded wires:</b> Replace wire. <b>Ground wire loose:</b> Clean and tighten ground.
LIGHTS FLICKERING	<b>Wires shorted or loose:</b> Locate, insulate, replace, or tighten.
LIGHTS DIM	<b>Voltage difference between trailer &amp; tractor:</b> Tractor supply wire or circuit components too low capacity - enlarge wire or component, match bulbs with tractor voltage.
LIGHTS BRIGHT & BURN OUT	<b>Ground wire disconnected:</b> Self-explanatory. <b>Voltage difference between trailer &amp; tractor:</b> Tractor supply wire or circuit components too low capacity - enlarge wire or component, match bulbs with tractor voltage.
FUSE BLOW-OUT OR CIRCUIT BREAKER TRIPPING	<b>Vibration:</b> Locate source of vibration and repair. <b>Short circuit:</b> Replace fuse and try all accessories. If fuse blows right away, locate short and repair.
LAMP BULB BURN OUT	<b>Vibration:</b> Locate source of vibration and repair. <b>Short circuit:</b> Replace fuse and try all accessories. If fuse blows right away, locate short and repair. <b>Loose connection:</b> Check lamp sockets and ground connections. <b>Intermittent short:</b> Locate short and repair. <b>Improper voltage:</b> Check voltage regulator output.

## 5-2 TIRES - WHEELS - SUSPENSION

---

Most tire, wheel, and suspension related problems are due to excessive loads, extreme conditions, and improper maintenance. Tire, wheel, and suspension problems can be easily detected and solved by checking the following guide. For maintenance procedures, **see Sections 4-7 thru 4-11.**

<b>SYMPTOM</b>	<b>PROBLEM: REMEDY</b>
VIBRATIONS WHILE DRIVING	<b>Improper tire inflation:</b> Inflate to proper pressure. <b>Tires cupped or have flat spots:</b> Replace tires. <b>Wheels bent or loose:</b> Replace or tighten. <b>Tires incorrectly mounted:</b> Remount. <b>Mud in wheels:</b> Clean wheels. <b>Tire(s) out of balance:</b> Balance tires. <b>Brakes dragging:</b> Locate cause and repair.
<b>RAPID TIRE WEAR/DETERIORATION:</b>	
CENTER TREAD WEAR	<b>Over inflation:</b> Deflate to correct inflation.
SHOULDER TREAD WEAR - BOTH SHOULDERS	<b>Under inflation: Increase inflation to correct psi.</b> <b>Check axle alignment.</b> <b>Overload:</b> Loads are above rated tire capacity. <b><i>Do not load above rated tire capacity.</i></b>
SHOULDER TREAD WEAR - ONE SHOULDER	<b>Axle damage:</b> Straighten or replace axle. <b>Axles not parallel:</b> Check axle alignment.
OVERALL TREAD WEAR	<b>Overloading:</b> Check tire load rating. <b>High speeds:</b> Adjust speed according to road and load conditions.
TIRE FLAT SPOTS	<b>Quick stops:</b> Adjust braking practices. <b>Grabbing brakes:</b> Adjust brakes properly. <b>Worn or loose wheel bearings:</b> Adjust or replace as needed. <b>Out of balance wheels and tire:</b> Balance wheels and tires.
UNEVEN WEAR	<b>Suspension bushings worn:</b> Replace bushings. <b>Worn or loose wheel bearings:</b> Adjust or replace as needed. <b>Out of balance wheels and tires:</b> Balance wheels and tires.
<b>RIM FAILURE*:</b>	
CRACKING	<b>Overinflated tires:</b> Deflate tire to proper psi. <b>High speeds:</b> Adjust speed according to road and load conditions. <b>High speed cornering:</b> Adjust cornering practices. <b>Over loading:</b> Check rim load rating.

**\*In all instances of rim failure, replace the rim immediately!**

**SYMPTOM****PROBLEM: REMEDY**

BENDING OR WARPING

**Curb-hopping or potholes:** Adjust turning practices and adjust speed accordingly with road conditions.  
**Improper tightening sequence:** Follow proper tightening sequence.

BROKEN STUDS\*

**Over-tightening:** Use correct torque and tightening sequence when mounting.

\*Replace broken studs before using the trailer!,

**TRAILER TRACKING PROBLEMS:**

TRACKS TO ONE SIDE

**Axle bent:** Replace axle.

TRACKS TO EITHER SIDE

**Broken or bent axle parts:** Replace axle.

**5-3 ELECTRIC BRAKES**

For maintenance procedures, see Section 4-6.

**SYMPTOM****PROBLEM: REMEDY**

NO BRAKES

**Open circuits:** Find and correct.  
**Severe Underadjustment:** Adjust brakes.  
**Faulty Controller:** Test and correct.  
**Short Circuits:** Find and correct.

WEAK BRAKES

**Grease or Oil on Magnets or Linings:** Clean or replace .  
**Corroded Connections:** Clean and correct cause of corrosion.  
**Worn Linings or Magnets:** Replace.  
**Scored or Grooved Brake Drums:** Machine or replace.  
**Improper Synchronization:** Correct.  
**Underadjustment:** Adjust brakes.  
**Glazed Linings:** Reburnish or replace.  
**Overloaded Trailer:** Reduce to within load restrictions.

LOCKING BRAKES

**Underadjustment:** Adjust brakes.  
**Improper Synchronization:** Correct.  
**Faulty Controller:** Test and correct.  
**Loose, Bent, or Broken Brake Components:** Replace components.  
**Out-of-Round Brake Drums:** Machine or replace.  
**Insufficient Wheel Load:** Adjust system resistor and synchronize.

INTERMITTENT BRAKES

**Faulty Controller:** Test and correct.  
**Broken Wires:** Repair or replace.  
**Loose Connections:** Find and repair.  
**Faulty Ground:** Find and repair.

**SYMPTOM****PROBLEM: REMEDY**

BRAKES PULL TO ONE SIDE

**Wrong Magnet Lead Wire Color:** Correct.  
**Incorrect Adjustment:** Adjust.  
**Grease or Oil on Magnets or Linings:** Clean or replace .  
**Broken Wires:** Repair or replace.  
**Bad Connections:** Find and repair.

HARSH BRAKES

**Underadjustment:** Adjust brakes.  
**Improper Synchronization:** Correct.  
**Improper Controller:** Change.  
**Faulty Controller:** Test and correct.

NOISY BRAKE

**Underadjustment:** Adjust brakes.  
**Broken Brake Components:** Replace components.  
**Incorrect Brake Components:** Correct.

SURGING BRAKES

**Grease or Oil on Magnets or Linings:** Clean or replace .  
**Out-of-Round Brake Drums:** Machine or replace.  
**Faulty Controller:** Test and correct.

DRAGGING BRAKES

**Overadjustment:** Readjust  
**Out-of-Round Brake Drums:** Machine or replace.  
**Incorrect Brake Components:** Replace.  
**Loose, Bent, or Broken Brake Components:** Replace components.  
**Faulty Breakaway Switch:** Repair or replace.  
**Broken Wires:** Repair or replace.  
**Loose Wheel Bearing Adjustment:** Adjust.  
**Bent Spindle:** Replace axle.

**5-4 SURGE HYDRAULIC BRAKES**

For maintenance procedures, see Section 4-6.

**SYMPTOM****PROBLEM: REMEDY**

NO BRAKES

**Severe Underadjustment:** Adjust brakes.  
**Broken Surge Brake Components:** Find and replace.  
**Broken Hydraulic Line:** Find and replace.  
**No Brake Fluid:** Fill per maintenance schedule.  
**Operation of Actuator Hampered:** Remove devices or obstructions that prevent the actuator from being free to telescope in response to braking requirements.

WEAK BRAKES

**Worn Brake Linings:** Replace.  
**Scored or Grooved Brake Drums:** Machine or replace.  
**Underadjustment:** Adjust brakes.  
**Glazed Linings:** Reburnish or replace.  
**Overloaded Trailer:** Reduce to within load restrictions.

LOCKING BRAKES

**Underadjustment:** Adjust brakes.  
**Breakaway accidentally applied:** Pry the breakaway locks apart to release lever.  
**Loose, Bent, or Broken Brake Components:** Replace components.  
**Out-of-Round Brake Drums:** Machine or replace.

INTERMITTENT BRAKES

**Operation of actuator hampered:** Find obstructions or broken parts and repair.

BRAKES PULL TO ONE SIDE

**Incorrect Adjustment:** Adjust.  
**Grease or Oil on Linings:** Clean or replace.

HARSH BRAKES

**Underadjustment:** Adjust brakes.

NOISY BRAKE

**Underadjustment:** Adjust brakes.  
**Broken Brake Components:** Replace components.  
**Incorrect Brake Components:** Correct.

SURGING BRAKES

**Grease or Oil on Linings:** Clean or replace .  
**Out-of-Round Brake Drums:** Machine or replace.

DRAGGING BRAKES

**Overadjustment:** Readjust  
**Out-of-Round Brake Drums:** Machine or replace.  
**Incorrect Brake Components:** Replace.  
**Loose, Bent, or Broken Brake Components:** Replace components.  
**Loose Wheel Bearing Adjustment:** Adjust.  
**Bent Spindle:** Replace axle.

## 5-5 BED TILT

---

Locate the symptom in this section that best identifies your bed tilt problem. Check out each possible problem under that symptom.

**SYMPTOM**

**PROBLEM: REMEDY**

---

BED TILTS TOO SLOW

**Dirty oil:** Replace oil and check for particles in the restrictor fitting.  
**Heavy weight oil:** Replace oil with lighter weight oil.  
**Damaged cylinder:** Replace cylinder or the broken parts of cylinder.

**SYMPTOM****PROBLEM: REMEDY**

---

BED TILTS TOO FAST

**Not enough oil in cylinder:** Fill with oil according to maintenance procedure.  
**Light weight oil:** Replace oil with heavier weight oil.  
**Bad cylinder seals:** Replace cylinder seals.

BED WILL NOT MOVE

**Too full of oil:** Fill with oil according to maintenance procedure.  
**Bed latch locked:** Unlock over-center latch.  
**Cylinder damaged:** Replace cylinder.

BED WILL NOT FULLY RETRACT

**Too full of oil:** Fill with oil according to maintenance procedure.  
**Something between bed and hitch:** Remove obstruction.  
**Cylinder damaged:** Replace cylinder.

BED WILL NOT TOUCH GROUND

**Hitch setting is incorrect:** Readjust front hitch position so hitch beams are level or a slight incline up. (This is done by unbolting front hitch and lowering to next lower hole position.)  
**Trailer positioned on unlevel surface:** Load and unload on fairly level ground.  
**Cylinder damaged:** Replace cylinder. (The centerline pin to centerline pin dimension should be 40" when fully extended.)

BED DOES NOT STAY TILTED WITH THE LOAD  
LOADING VALVE

**Cylinder seal damaged:** Replace seal in cylinder  
**Holding valve damaged:** Replace holding valve  
**Air in the hydraulic system:** See Section 4-13 for removing air from the hydraulic system.