

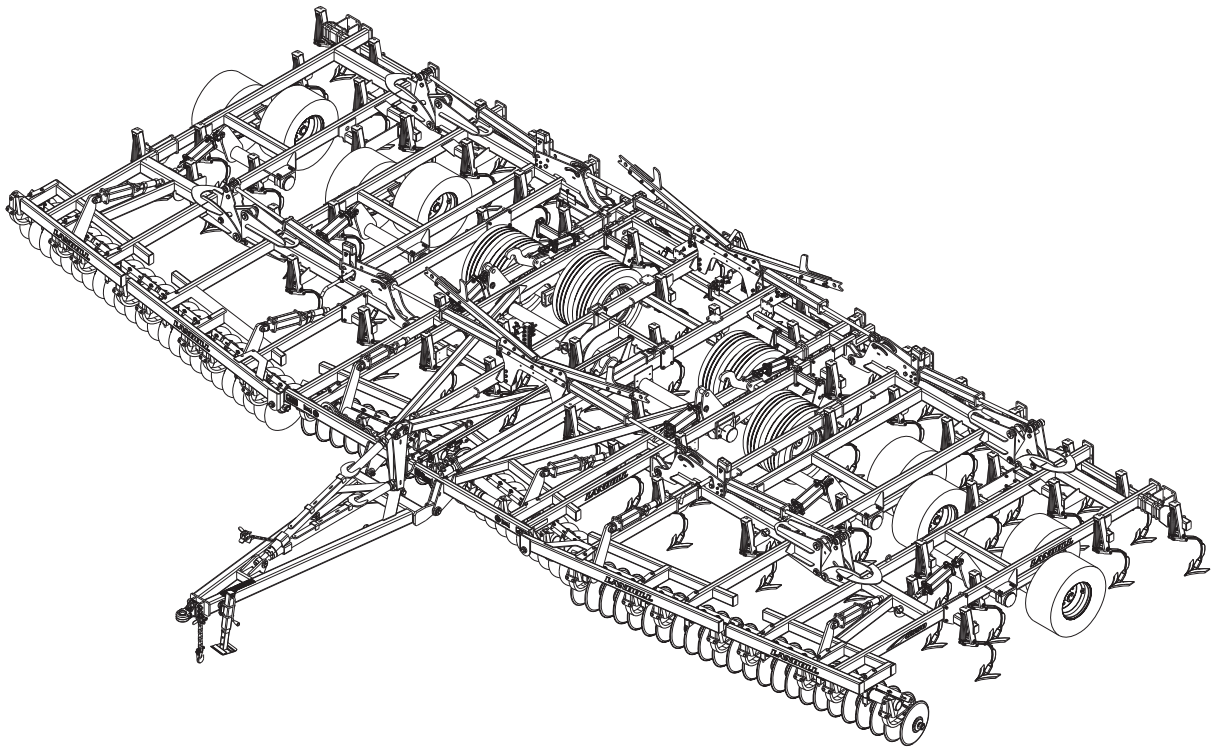

Model 8550 Finishroll Operator's Manual



LANDOLL COMPANY, LLC

1900 North Street
Marysville, Kansas 66508
(785) 562-5381

800-428-5655 ~ WWW.LANDOLL.COM

Table of Contents

1 Introduction and Safety Information

Introduction	1-1
Understanding Safety Statements	1-2
Decal Safety	1-2
Transporting Safety	1-2
Attaching, Detaching, and Storage	1-3
Maintenance Safety	1-3
High Pressure Fluid Safety	1-3
Protective Equipment	1-3
Chemical Safety	1-3
Prepare for Emergencies	1-3
Tire Safety	1-3
Safety Chain	1-4

2 Standard Specifications

Model Specifications	2-1
General Torque Specifications (rev. 4/97)	2-2
Hydraulic Fitting Torque Specifications	2-3
Shank & Light Bracket Placement	2-4
4 Row Coil Tine Placement	2-10
3 Row Tine & Reel Placement	2-16
5 Row Spike Placement	2-22
3 Row Spike & Reel Placement	2-31
Spike & Double Reel Placement	2-40
Chopper & 3 Row Spike Placement	2-49
Chopper/Spike/Reel Placement	2-58

3 Assembly Instructions

Frame and Hitch Assembly	3-2
LED Light and SMV Bracket Installation	3-8
Inner Wing Installation	3-11
Outer Wing Frames	3-13
Disc Gang Installation	3-15
Optional Gang Shield Assembly	3-18
Disc Gang Reel Assembly (Optional)	3-20
Hydraulic Installation	3-22
Shank Installation	3-36
Final Assembly	3-38

4 Operation and Maintenance

Tractor Preparation	4-2
Attaching to the Tractor	4-2
Hydraulic Lift System	4-3
Hydraulic Fold System	4-4
Folding the 8550 Finisholl	4-5
Unfolding the 8550 Finisholl	4-5
Transporting	4-6
LED Light Operation	4-8
General Operation	4-8
Leveling (Side to Side)	4-8
Leveling (Front-to-Rear)	4-9
Depth Stop Adjustment	4-9
Disc Blades	4-10
Disc Gang Operation	4-10
Disc Gang Assembly	4-11
Scraper Adjustment	4-11
Shanks	4-12
S-tine Shanks	4-12
Spring Shanks	4-12
Sweeps	4-12
Lubrication	4-13
8550 Finisholl Wheel Bearing Maintenance	4-14
Center Frame	4-14
Wing Frame - Wheel Bearing Maintenance – Non Triple-Lip	4-16
Wheel Bearing Maintenance -- Triple-Lip	4-16
Storage	4-31

5 Troubleshooting Guide

Introduction and Safety Information

Introduction

The Landoll Model 8550 Finisholl is a quality product designed to give years of trouble free performance. By following each section of this manual, your system will perform as designed for you and your operation.

- CHAPTER 1** Gives basic instructions on the use of this manual and understanding the safety statements.
- CHAPTER 2** Gives product specifications for the equipment. These specifications supply lengths and measures for your equipment. A Standard Bolt Torque Table is provided to give guidelines for bolt torques to be used when servicing this product.
- CHAPTER 3** Contains assembly instructions for your 8550 Finisholl. When these procedures are correctly followed, your equipment should provide you years of trouble-free operation and service.
- CHAPTER 4** Instructs how to operate your equipment before using it, and describes adjustments needed. Gives practical advice for the care and maintenance of your Landoll equipment. Drawings in this section locate adjustment points on the equipment.

IF YOU HAVE ANY QUESTIONS CONTACT:

**LANDOLL COMPANY, LLC
1900 NORTH STREET
MARYSVILLE, KANSAS 66508**

PHONE # (785) 562-5381 or (800) 428-5655

OR

FAX # (888) 527-3909

- CHAPTER 5** Is a troubleshooting guide to aid in diagnosing and solving problems with the Finisholl
- PARTS MANUAL** Is a separate manual showing the various assemblies, subassemblies, and systems. Refer to that manual when ordering Landoll replacement parts. Order parts from your Landoll dealer.
- WARRANTY** The Warranty Registration form is included with the product documents. Fill it out and mail it within 15 days of purchase.
NOTE: IMPROPER ASSEMBLY, MODIFICATION, OR MAINTENANCE OF YOUR LANDOLL MACHINE CAN VOID YOUR WARRANTY.
- COMMENTS** Address comments or questions regarding this publication to:

**LANDOLL COMPANY, LLC
1900 NORTH STREET
MARYSVILLE, KANSAS 66508
ATTENTION: PUBLICATIONS - DEPT. 55**

Understanding Safety Statements

You will find various types of safety information on the following pages and on the machine signs (decals) attached to the vehicle. This section explains their meaning.



The Safety Alert Symbol means **ATTENTION! YOUR SAFETY IS INVOLVED!**

NOTE

Means that failure to follow these instructions could cause damage to the equipment or cause it to operate improperly.

NOTICE

Special notice - read and thoroughly understand



CAUTION

Caution means serious equipment or other property damage can occur if instructions on this label are not properly followed.



WARNING

Warning means serious injury or death can occur if safety measures or instructions on this label are not properly followed.



DANGER

Danger means a life-threatening situation exists. Death can occur if safety measures or instructions on this label are not properly followed.

NOTE

Make sure you read and understand the information contained in this manual and on the machine signs (decals) before you attempt to operate or maintain this vehicle.

The safety statements contained in this manual relate to the operation of the Model 8550 Finisholl semitrailer.

Decal Safety

1. Examine safety decals and be sure you have the correct safety decals for the implement.
2. Keep these signs clean so they can be observed readily. It is important to keep these decals cleaned more frequently than the implement. Wash with soap and water or a cleaning solution as required.
3. Replace decals that become damaged or lost. Also, be sure that any new implement components installed during repair include decals which are assigned to them by the manufacturer.
4. When applying decals to the implement, be sure to clean the surface to remove any dirt or residue. Where possible, sign placement should protect the sign from abrasion, damage, or obstruction from mud, dirt, oil etc.



DANGER

- Do not allow anyone to ride on the tractor or implement. Riders could be struck by foreign objects or thrown from the implement.
- Never allow children to operate equipment.
- Keep bystanders away from implement during operation.

Transporting Safety

IMPORTANT

It is the responsibility of the owner/operator to comply with all state and local laws.

1. When transporting the implement on a road or highway, use adequate warning symbols, reflectors, lights and slow moving vehicle sign as required. Slow moving tractors and towed implements can create a hazard when driven on public roads. They are difficult to see, especially at night.



2. Do not tow an implement that, when fully loaded, weighs more than 1.5 times the weight of the towing vehicle.
3. Carry reflectors or flags to mark the tractor and implement in case of breakdown on the road.

4. Do not transport at speeds over 20 MPH under good conditions. Never travel at a speed which does not allow adequate control of steering and stopping. Reduce speed if towed load is not equipped with brakes
5. Avoid sudden stops or turns because the weight of the implement may cause the operator to lose control of the tractor. Use a tractor heavier than the implement.
6. Use caution when towing behind articulated steering tractors; fast or sharp turns may cause the implement to shift sideways.
7. Keep clear of overhead power lines and other obstructions when transporting. Know the transport height and width of your implement.

Attaching, Detaching, and Storage

1. Do not stand between the tractor and implement when attaching or detaching implement unless both are not moving.
2. Block implement so it will not roll when unhitched from the tractor.
3. Store in an area where children normally do not play.

Maintenance Safety

1. Understand the procedure before doing the work. Use proper tools and equipment.
2. Make sure all moving parts have stopped.
3. Do not make adjustments or lubricate implement while it is in motion.
4. Block the implement so it will not roll when working on or under it to prevent injury.

High Pressure Fluid Safety

1. Escaping fluid under pressure can be nearly invisible and have enough force to penetrate the skin causing serious injury. Use a piece of cardboard, rather than hands, to search for suspected leaks.
2. Any fluid injected into the skin must be surgically removed within a few hours or gangrene may result.
3. Avoid the hazard by relieving pressure before disconnecting hydraulic lines.

Protective Equipment

1. Wear protective clothing and equipment.
2. Wear clothing and equipment appropriate for the job. Avoid loose fitting clothing.



3. Because prolonged exposure to loud noise can cause hearing impairment or hearing loss, wear suitable hearing protection, such as earmuffs or earplugs.

Chemical Safety

1. Agricultural chemicals can be dangerous. Improper use can seriously injure persons, animals, plants, soil and property.
2. Read chemical manufacture's instructions and store or dispose of unused chemicals as specified.
3. Handle chemicals with care and avoid inhaling smoke from any type of chemical fire.
4. Store or dispose of unused chemicals as specified by the chemical manufacturer.

Prepare for Emergencies

1. Keep a First Aid Kit and Fire Extinguisher handy.
2. Keep emergency numbers for doctor, ambulance, hospital and fire department near the phone.

Tire Safety

1. Tire changing can be dangerous and should be performed by trained personnel using correct tools and equipment.
2. When inflating tires, use a clip-on chuck and extension hose long enough to allow you to stand to one side, not in front of or over the tire assembly. Use a safety cage if available.
3. When removing and installing wheels use wheel-handling equipment adequate for the weight involved.

Safety Chain

1. Use a chain with a strength rating equal to or greater than the gross weight of towed machinery, which is 10,100 pounds minimum in accordance with ASAE S338.2 specifications. If two or more implements are pulled in tandem, a larger chain may be required. Chain capacity must be greater than the TOTAL weight of all towed implements.
2. A second chain should be used between each implement.
3. Attach the chain to the tractor drawbar support or specified anchor location. Allow only enough slack in the chain to permit turning. The distance from hitch pin to attachment point or intermediate support point should not exceed 9 inches.
4. Replace the chain if any links or end fittings are broken, stretched or damaged.
5. Do not use a safety chain for towing.

Standard Specifications

Model Specifications

8550 Finisholl			
Model Number	8550-38	8550-43	8550-48
Working Width	38'-0"	43'-4"	48'-8"
Transport Width	17'-10"	17'-10"	17'-10"
Transport Height	11'-3"	12'-7"	13'-11"
Number of Shanks	57	65	73
Shanks per Section	9-9-21-9-9	11-11-21-11-11	13-13-21-13-13
Spindle Size	4" Center Frame, 3" Wings	4" Center Frame, 3" Wings	4" Center Frame, 3" Wings
Wheel Bolt Pattern	8 Bolt Wheels	8 Bolt Wheels	8 Bolt Wheels
NOTE: Specifications Are Subject To Change Without Prior Notification			

Tire Inflation			
Tire Size	Tire Manufacturer	Ply/Load Rating	Inflation Pressure (Psi) (Max.)
VF 480/45 R17	BKT	167A8B - 12,015 lbs. @ 25mph	78 psi.
380/55 R16.5	Goodyear	7400 lbs. @ 30 mph	73 psi.
VF 410/50 R16.5	BKT	153A8/B - 8,050 lbs. @ 30 mph	73 psi
VF265/70 R19.5	FIRESTONE	LOAD INDEX 6,600 lbs. @ 40 mph	75 psi

Specific Bolt Torques	
Lug Bolts & Nuts	Torque (FT. LBS.)
Center Frame Inner Spindle/Hub	Torque to 100 FT.LBS while rotating. Back off to loose and tighten by hand until contact is made with bearing.
Center Frame Outer Spindle\Hub	300 Ft./Lbs.
Center Frame Wheel Nuts	450-500 Ft./Lbs.
Wing Frame Wheel Nuts	85-100 Ft./Lbs.
Disc Gang Shafts	1,200 Ft./Lbs.

General Torque Specifications (rev. 4/97)

TORQUE SPECIFIED IN FOOT POUNDS - This chart provides tightening torques for general purpose applications when special torques are not specified on process or drawing. Assembly torques apply to plated nuts and capscrews assembled without supplemental lubrication (as received condition). They do not apply if special graphite moly-disulfide or other extreme pressure lubricants are used. When fasteners are dry (solvent cleaned) add 33% to as received condition torque. Bolt head identification marks indicate grade and may vary from manufacturer to manufacturer. Thick nuts must be used on grade 8 capscrews. Use value in [] if using prevailing torque nuts.

UNC SIZE	SAE Grade 2	SAE Grade 5	SAE Grade 8	UNF SIZE	SAE Grade 2	SAE Grade 5	SAE Grade 8
1/4-20	4 [5]	6 [7]	9 [11]	1/4-28	5 [6]	7 [9]	10 [12]
5/16-18	8 [10]	13 [13]	18 [22]	5/16-24	9 [11]	14 [17]	20 [25]
3/8-16	15 [19]	23 [29]	35 [42]	3/8-24	17 [21]	25 [31]	35 [44]
7/16-14	24 [30]	35 [43]	55 [62]	7/16-20	27 [34]	40 [50]	60 [75]
1/2-13	35 [43]	55 [62]	80 [100]	1/2-20	40 [50]	65 [81]	90 [112]
9/16-12	55 [62]	80 [100]	110 [137]	9/16-18	60 [75]	90 [112]	130 [162]
5/8-11	75 [94]	110 [137]	170 [212]	5/8-18	85 [106]	130 [162]	180 [225]
3/4-10	130 [162]	200 [250]	280 [350]	3/4-16	150 [188]	220 [275]	320 [400]
7/8-9	125 [156]	320 [400]	460 [575]	7/8-14	140 [175]	360 [450]	500 [625]
1-8	190 [237]	408 [506]	680 [850]	1-14	210 [263]	540 [675]	760 [950]
1-1/8-7	270 [337]	600 [750]	960 [1200]	1-1/8-12	300 [375]	660 [825]	1080 [1350]
1-1/4-7	380 [475]	840 [1050]	1426 [1782]	1-1/4-12	420 [525]	920 [1150]	1500 [1875]
1-3/8-6	490 [612]	1010 [1375]	1780 [2225]	1-3/8-12	560 [700]	1260 [1575]	2010 [2512]
1-1/2-6	650 [812]	1460 [1825]	2360 [2950]	1-1/2-12	730 [912]	1640 [2050]	2660 [3325]
1-3/4-5	736 [920]	1651 [2063]	2678 [3347]	1-3/4-12	920 [1150]	2063 [2579]	3347 [4183]

METRIC:
 Coarse thread metric class 10.9 fasteners and class 10.0 nuts and through hardened flat washers, phosphate coated, Rockwell "C" 38-45. Use value in [] if using prevailing torque nuts.

Nominal thread diameter (mm)	Newton Meters (Standard Torque)	Foot Pounds (Standard Torque)	Nominal Thread Diameter (mm)	Newton Meters (Standard Torque)	Foot Pounds (Standard Torque)
6	10 [14]	7 [10]	20	385 [450]	290 [335]
7	16 [22]	12 [16]	24	670 [775]	500 [625]
8	23 [32]	17 [24]	27	980 [1105]	730 [825]
10	46 [60]	34 [47]	30	1330 [1470]	990 [1090]
12	80 [125]	60 [75]	33	1790 [1950]	1340 [1450]
14	125 [155]	90 [115]	36	2325 [2515]	1730 [1870]
16	200 [240]	150 [180]	39	3010 [3210]	2240 [2380]
18	275 [330]	205 [245]			

Table 2-1: General Torque Specifications

Hydraulic Fitting Torque Specifications

TORQUE IS SPECIFIED IN FOOT POUNDS- 37° JIC, ORS, & ORB (REV. 10/97)

This chart provides tightening torques for general purpose applications when special torques are not specified on process or drawing. Assembly torques apply to plated nuts and capscrews assembled without supplemental lubrication (as received condition). They do not apply if special graphite moly-disulfide or other extreme pressure lubricants are used. When fasteners are dry (solvent cleaned) add 33% to as received condition torque. Bolt head identification marks indicate grade and may vary from manufacturer to manufacturer. Thick nuts must be used on grade 8 capscrews. Use value in [] if using prevailing torque nuts.

Parker Brand Fittings			
Dash Size	37 Degree JIC	O-Ring (ORS)	O-Ring Boss (ORB)
-4	11-13	15-17	13-15
-5	14-16	-----	21-23
-6	20-22	34-36	25-29
-8	43-47	58-62	40-44
-10	55-65	100-110	58-62
-12	80-90	134-146	75-85
-16	115-125	202-218	109-121
-20	160-180	248-272	213-237
-24	185-215	303-327	238-262
-32	250-290	-----	310-340
Gates Brand Fittings			
Dash Size	37 Degree JIC	O-Ring (ORS)	O-Ring Boss (ORB)
-4	10-11	10-12	14-16
-5	13-15	-----	-----
-6	17-19	18-20	24-26
-8	34-38	32-40	37-44
-10	50-56	46-56	50-60
-12	70-78	65-80	75-83
-14	-----	65-80	-----
-16	94-104	92-105	111-125
-20	124-138	125-140	133-152
-24	156-173	150-180	156-184
-32	219-243	-----	-----
Aeroquip Brand Fittings			
Dash Size	37 Degree JIC	O-Ring (ORS)	O-Ring Boss (ORB)
-4	11-12	10-12	14-16
-5	15-16	-----	16-20
-6	18-20	18-20	24-26
-8	38-42	32-35	50-60
-10	57-62	46-50	75-80
-12	79-87	65-70	125-135
-14	-----	-----	160-180
-16	108-113	92-100	200-220
-20	127-133	125-140	210-280
-24	158-167	150-165	270-360
-32	245-258	-----	-----

Table 2-2: Hydraulic Fitting Torque Specifications

Shank & Light Bracket Placement

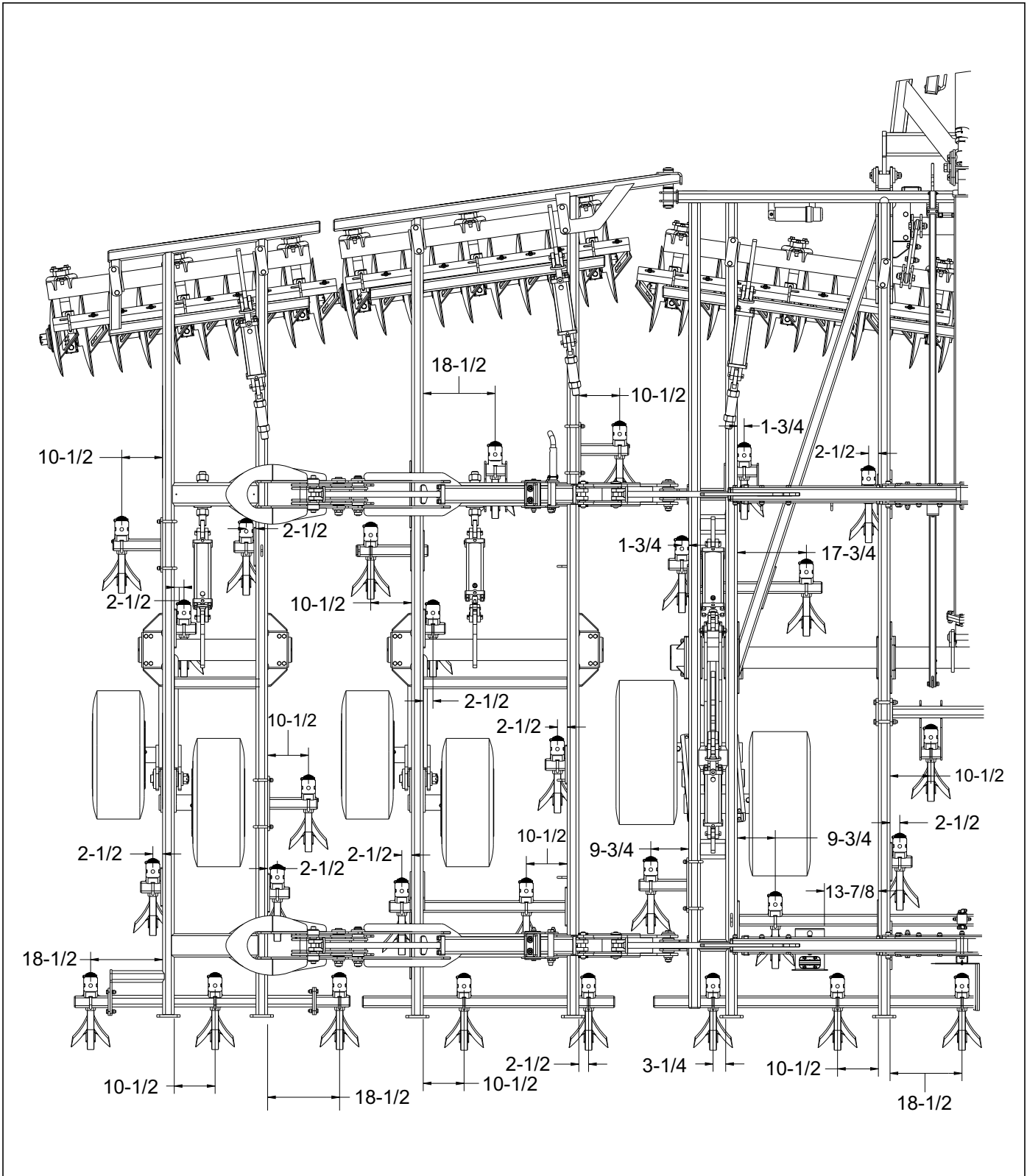

Figure 2-1: Shank Placement - 38' (Left Half)

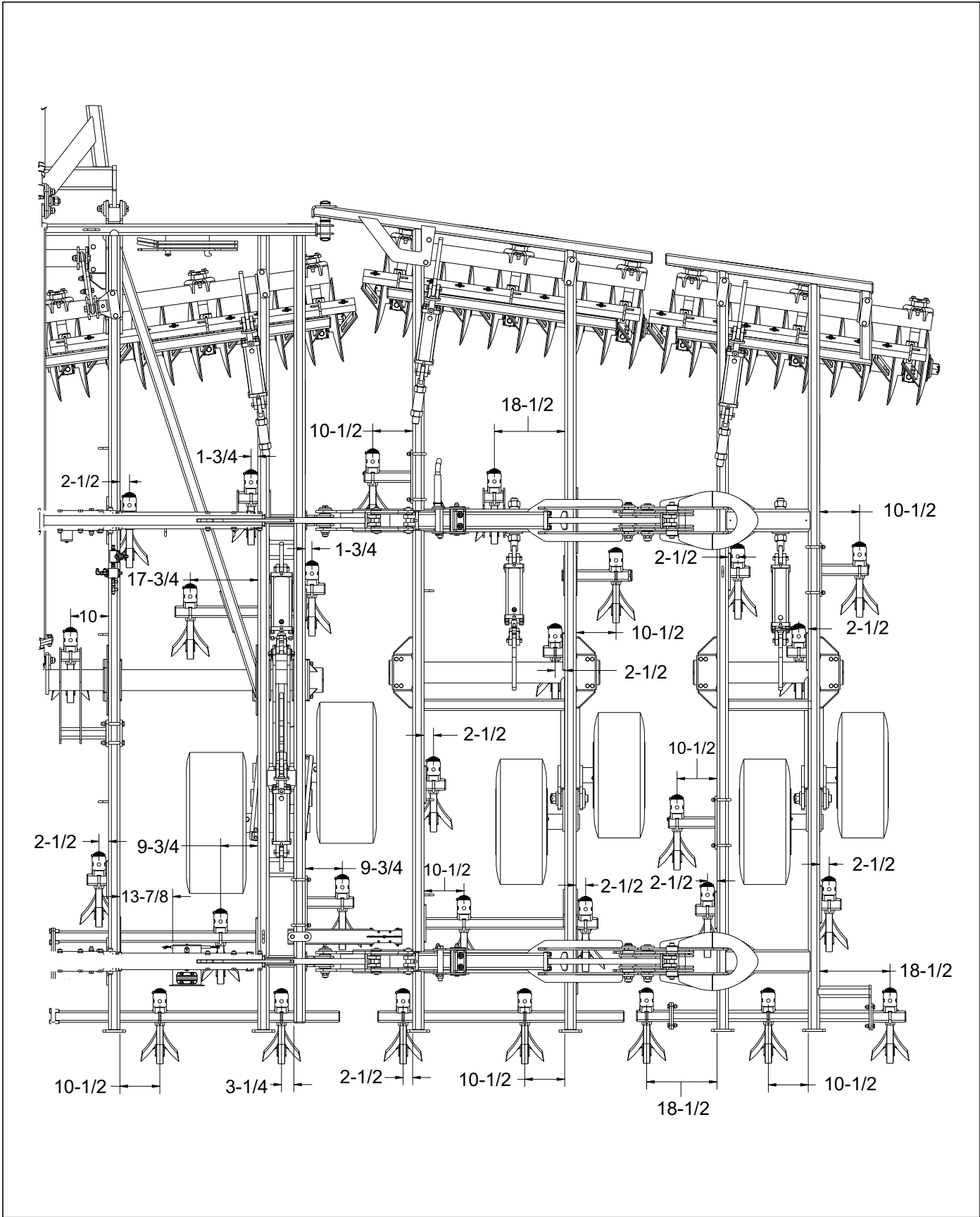

Figure 2-2: Shank Placement - 38' (Right Half)

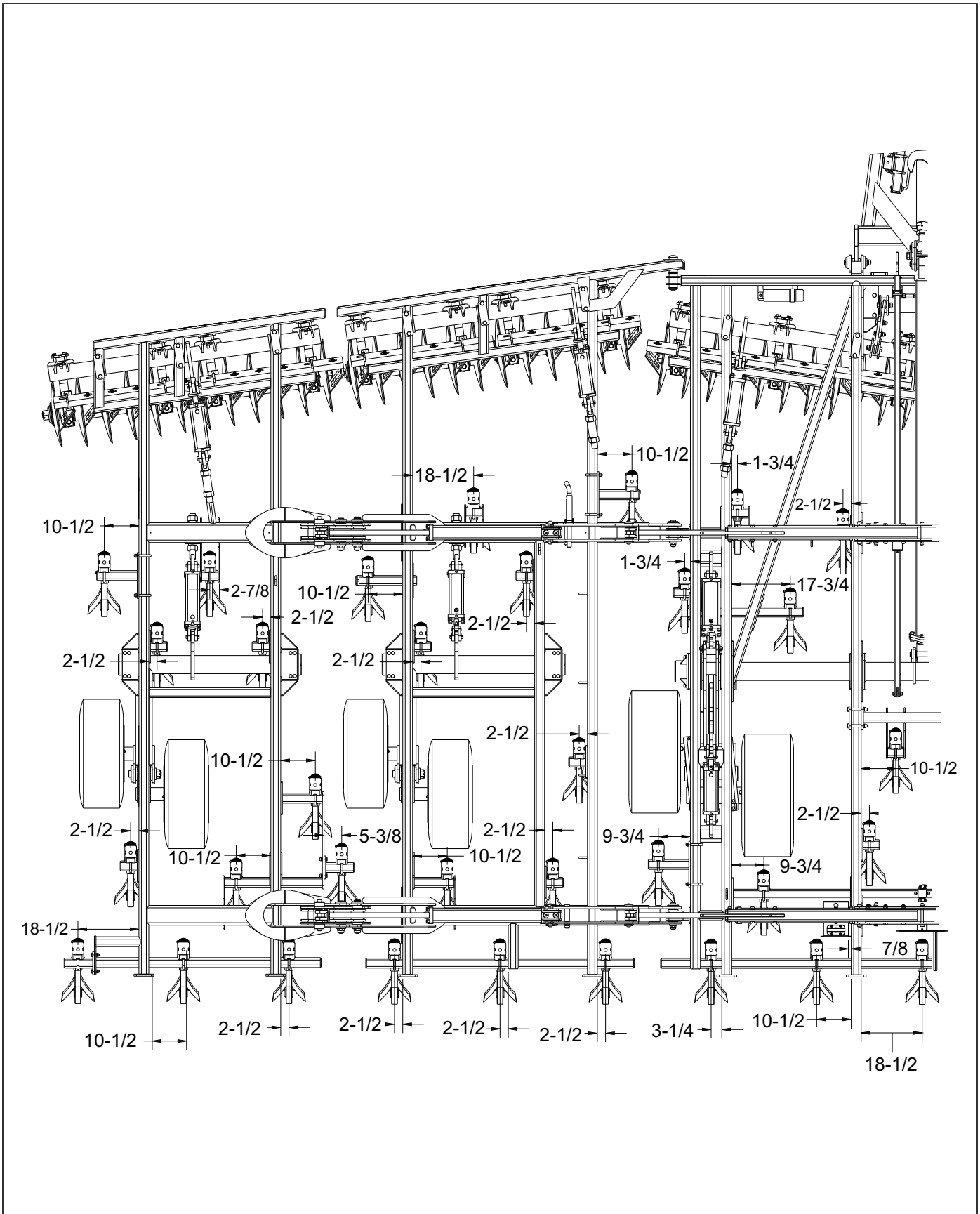

Figure 2-3: Shank Placement - 43' (Left Half)

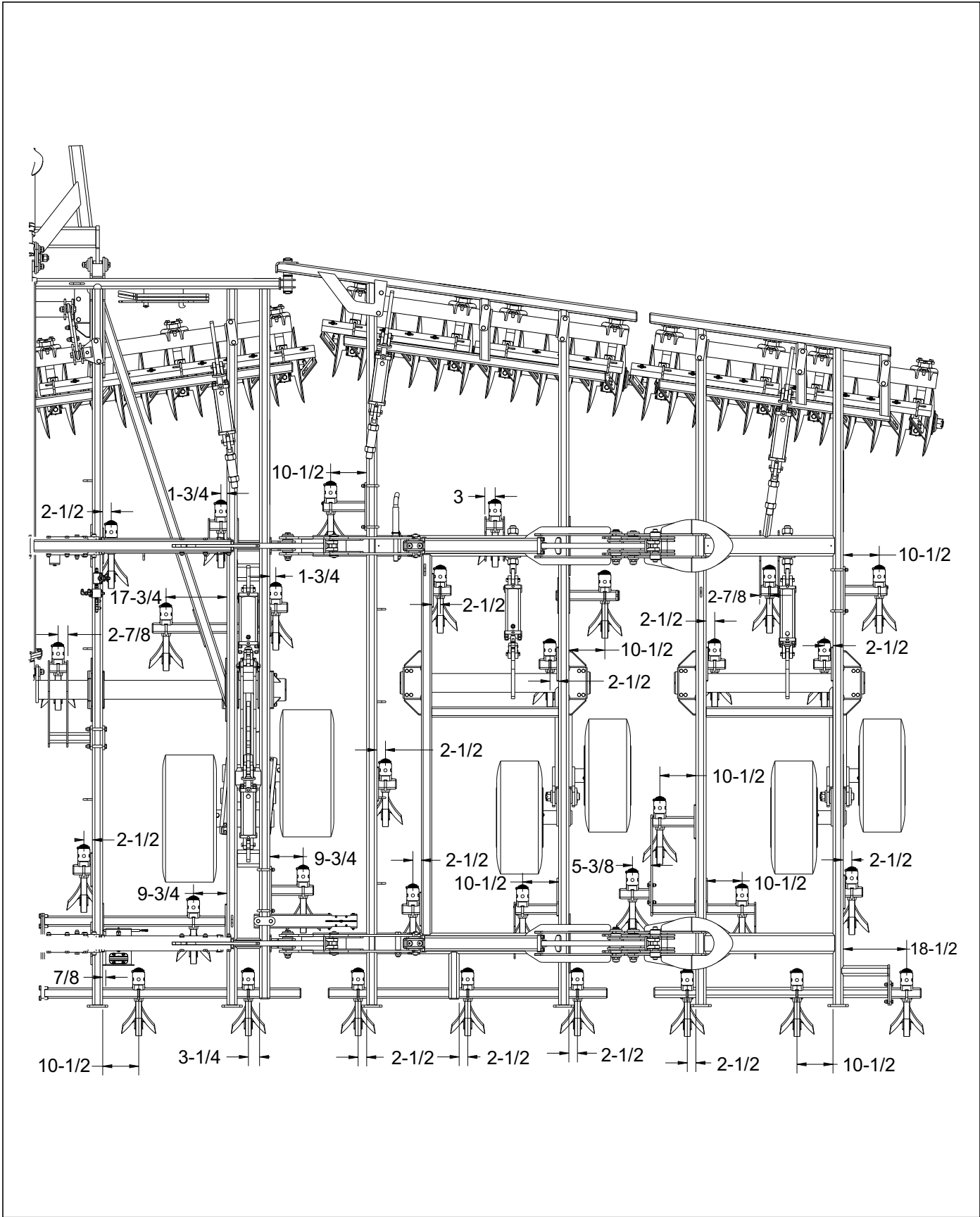

Figure 2-4: Shank Placement - 43' (Right Half)

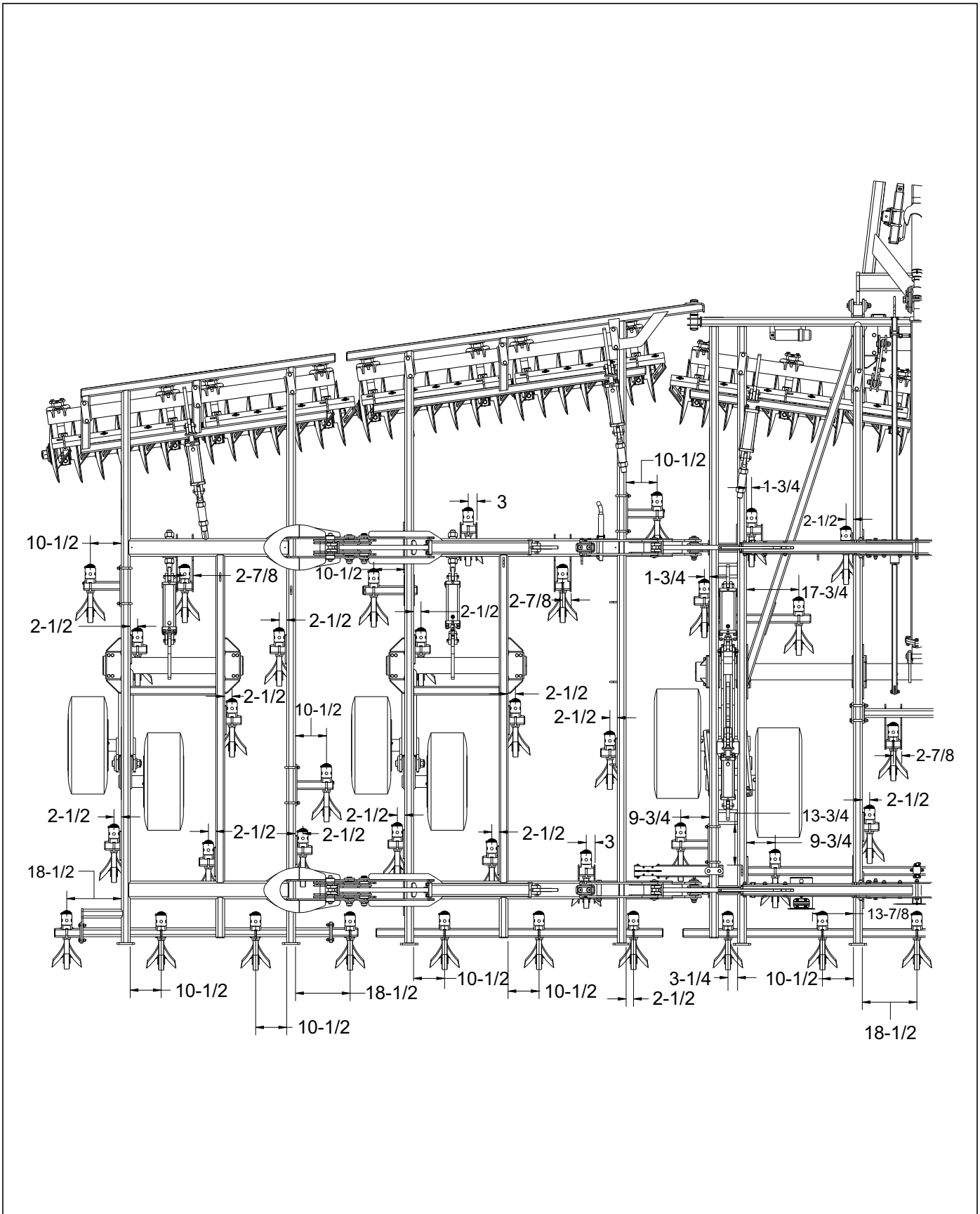

Figure 2-5: Shank Placement - 48' (Left Half)

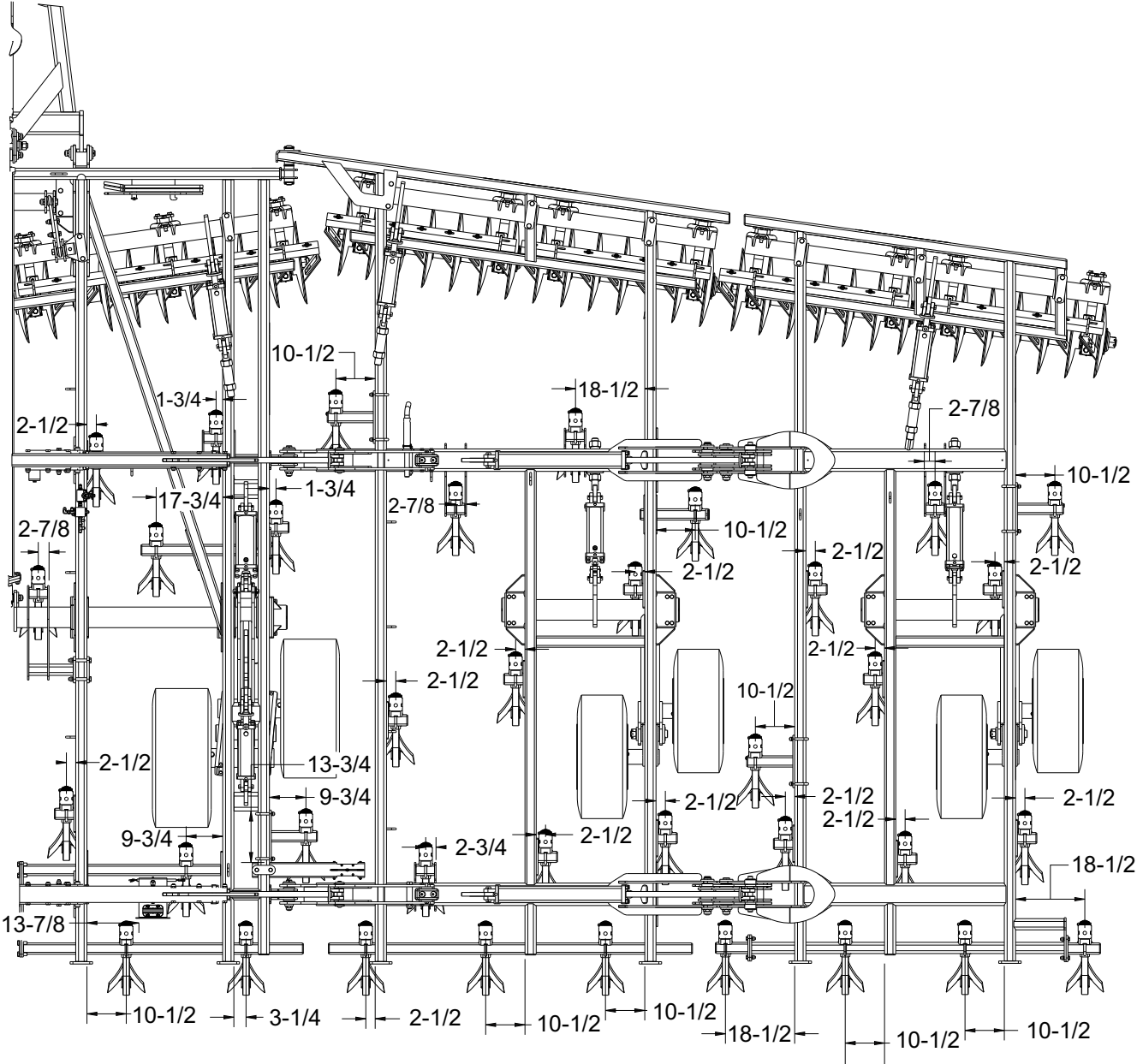

Figure 2-6: Shank Placement - 48' (Right Half)

4 Row Coil Tine Placement

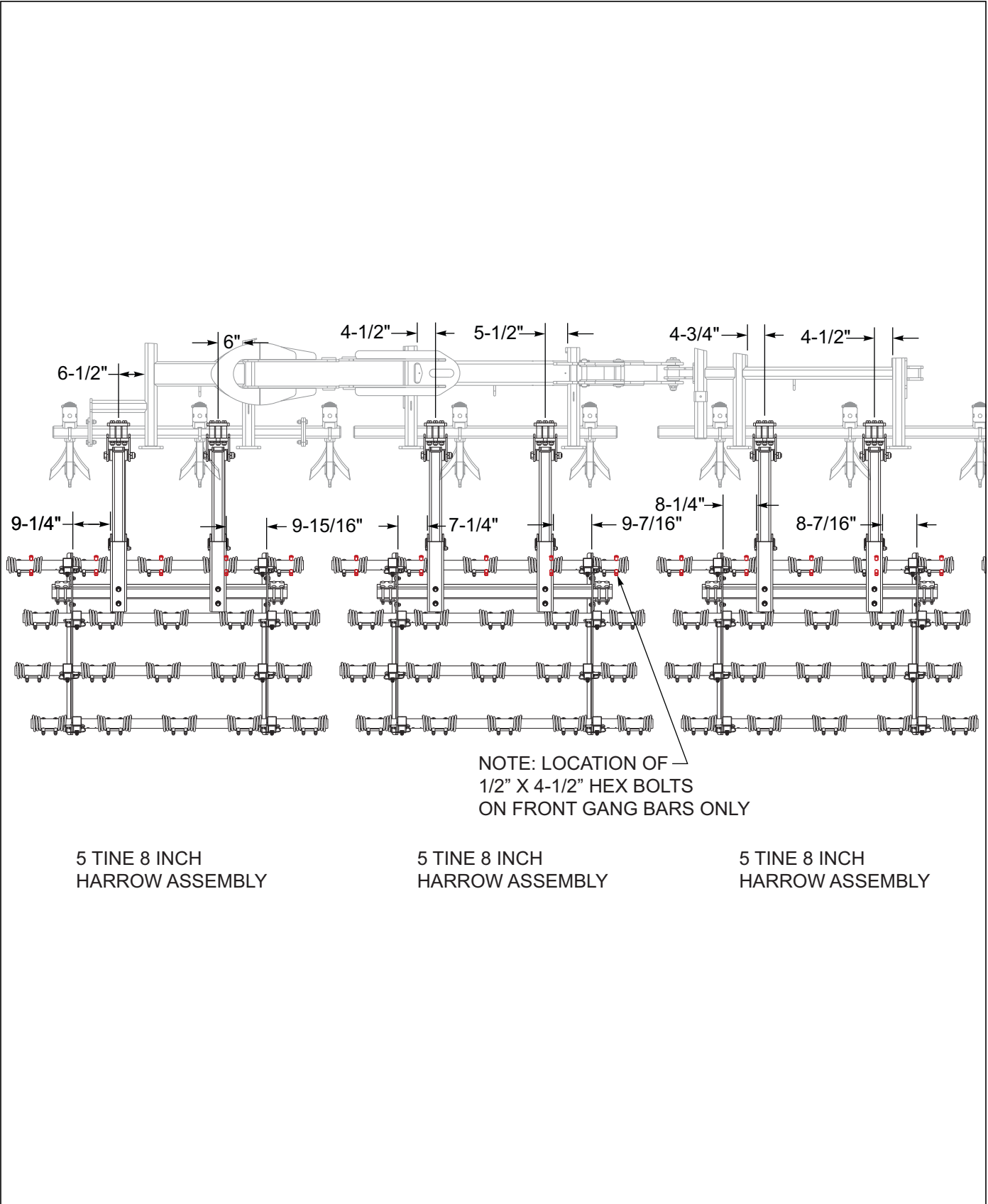

Figure 2-7: 4 Row CT Placement 8550-38' LH

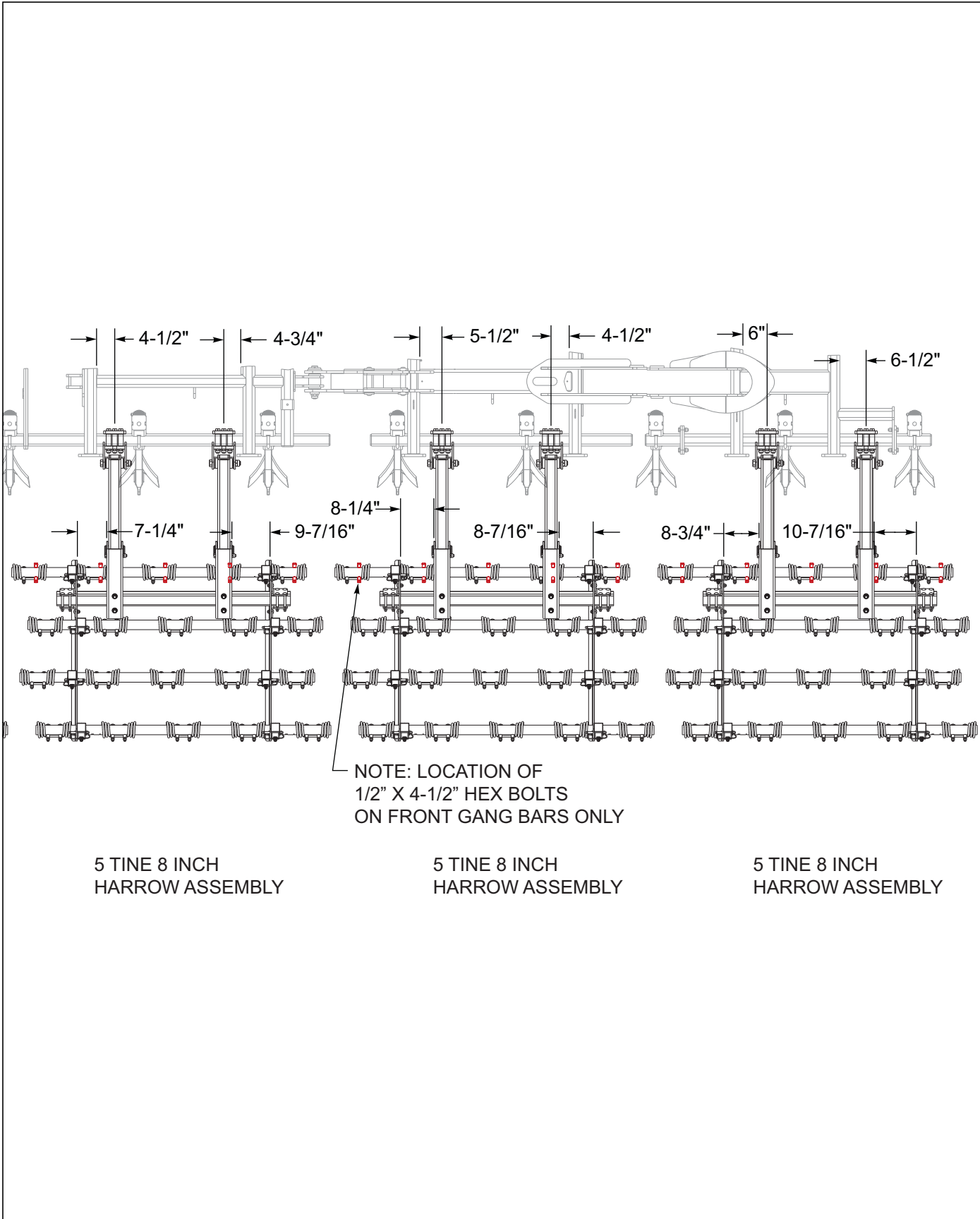

Figure 2-8: 4 Row CT Placement 8550-38' RH

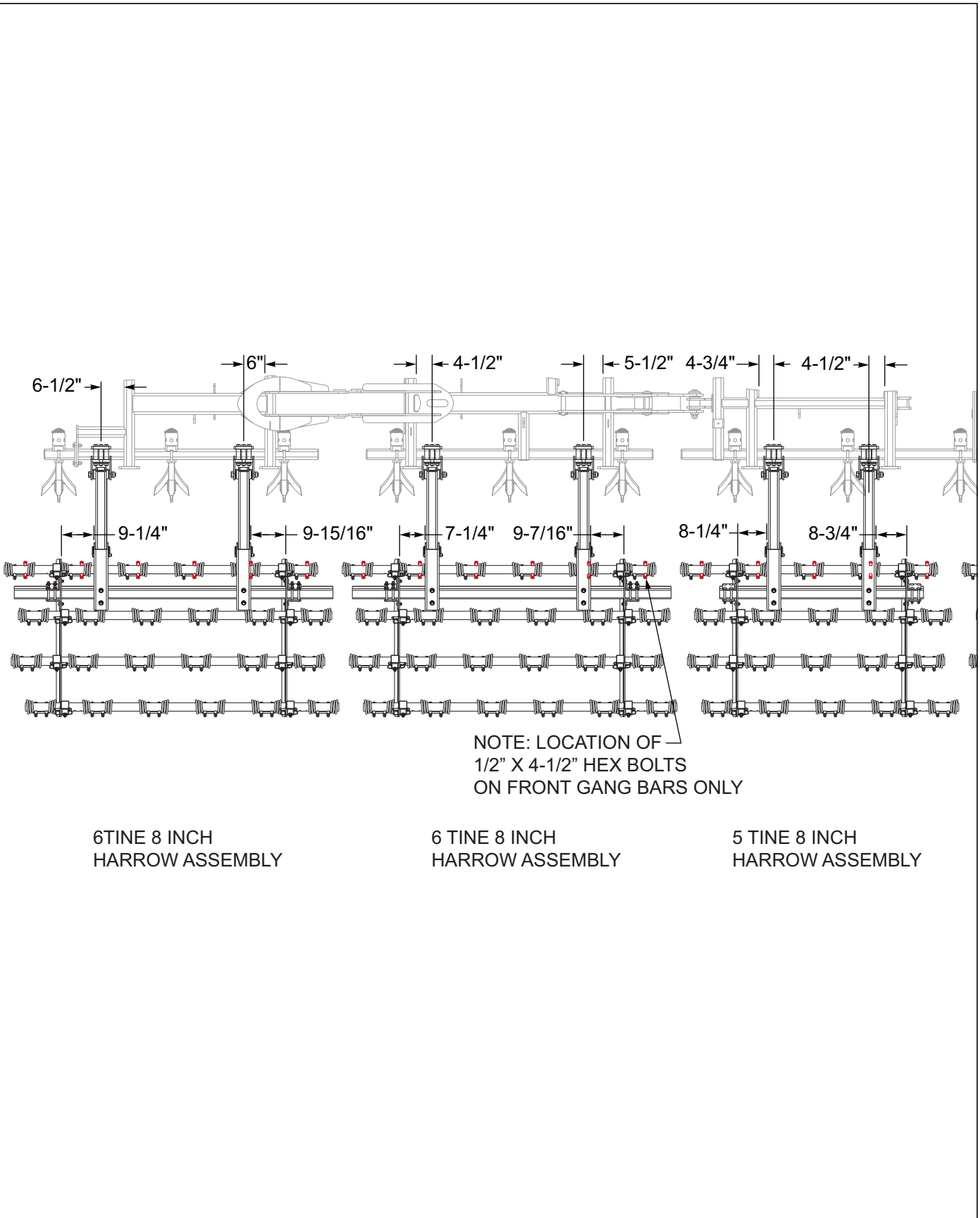

Figure 2-9: 4 Row CT Placement 8550-43' LH

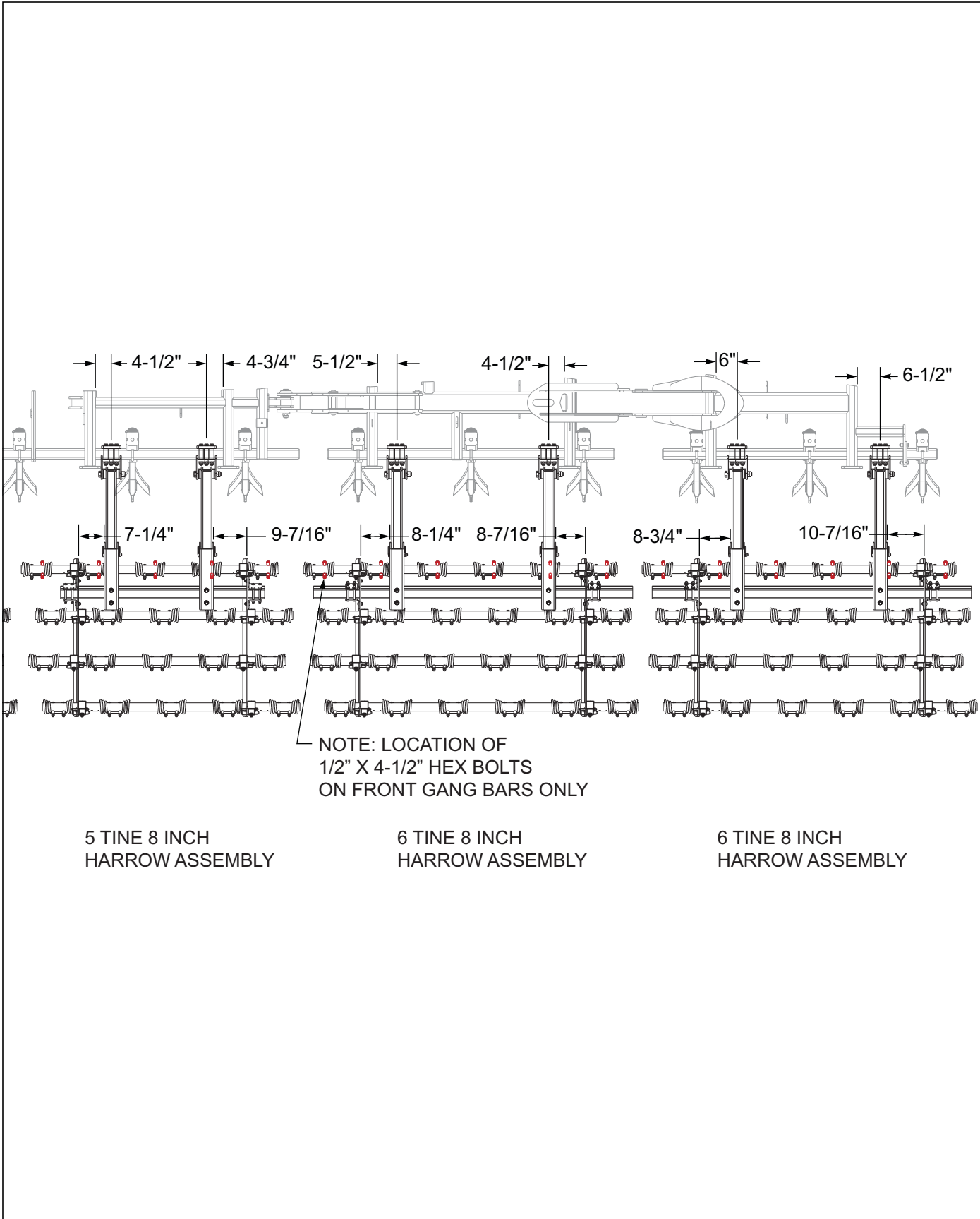

Figure 2-10: 4 Row CT Placement 8550-43' RH

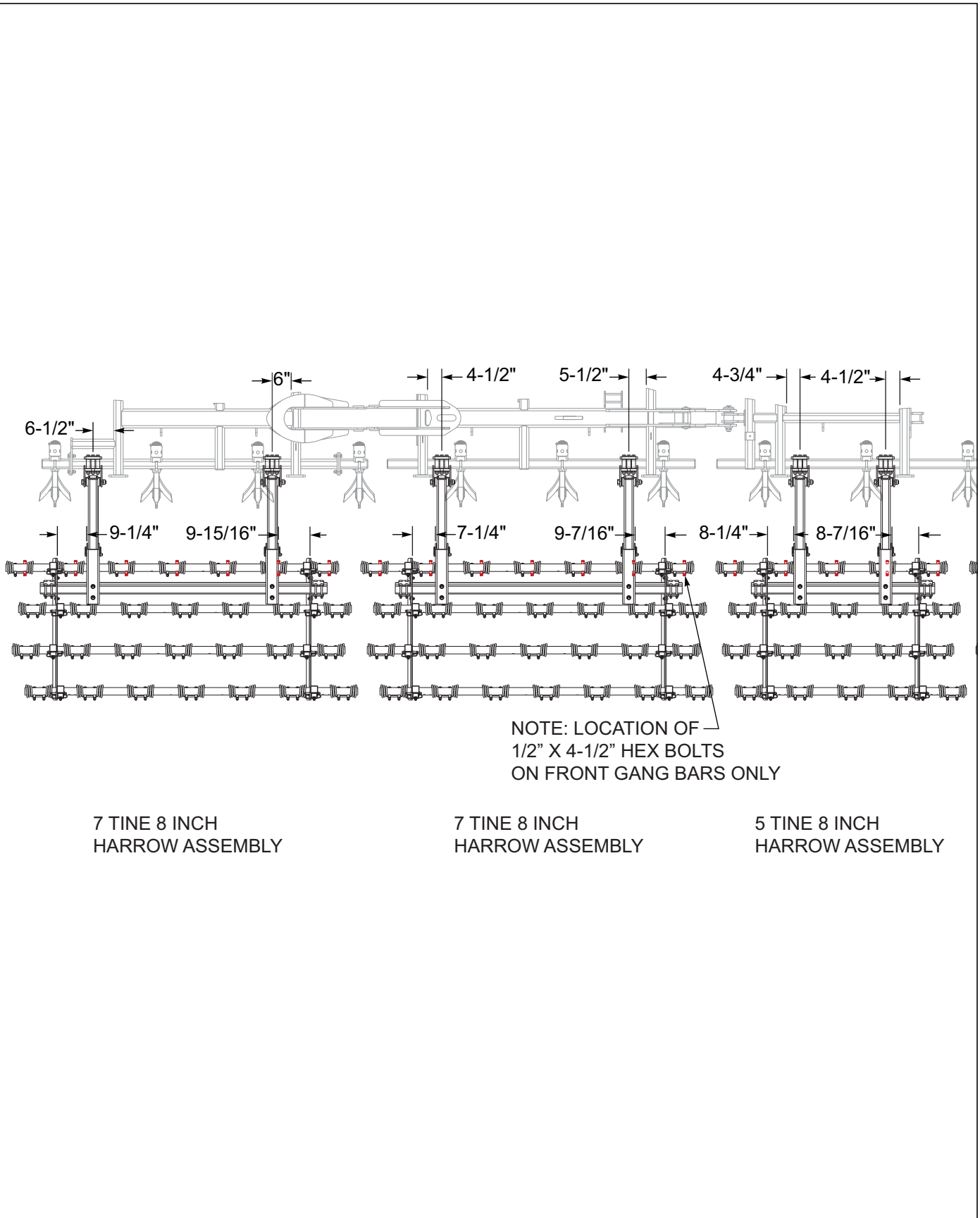

Figure 2-11: 4 Row CT Placement 8550-48' LH

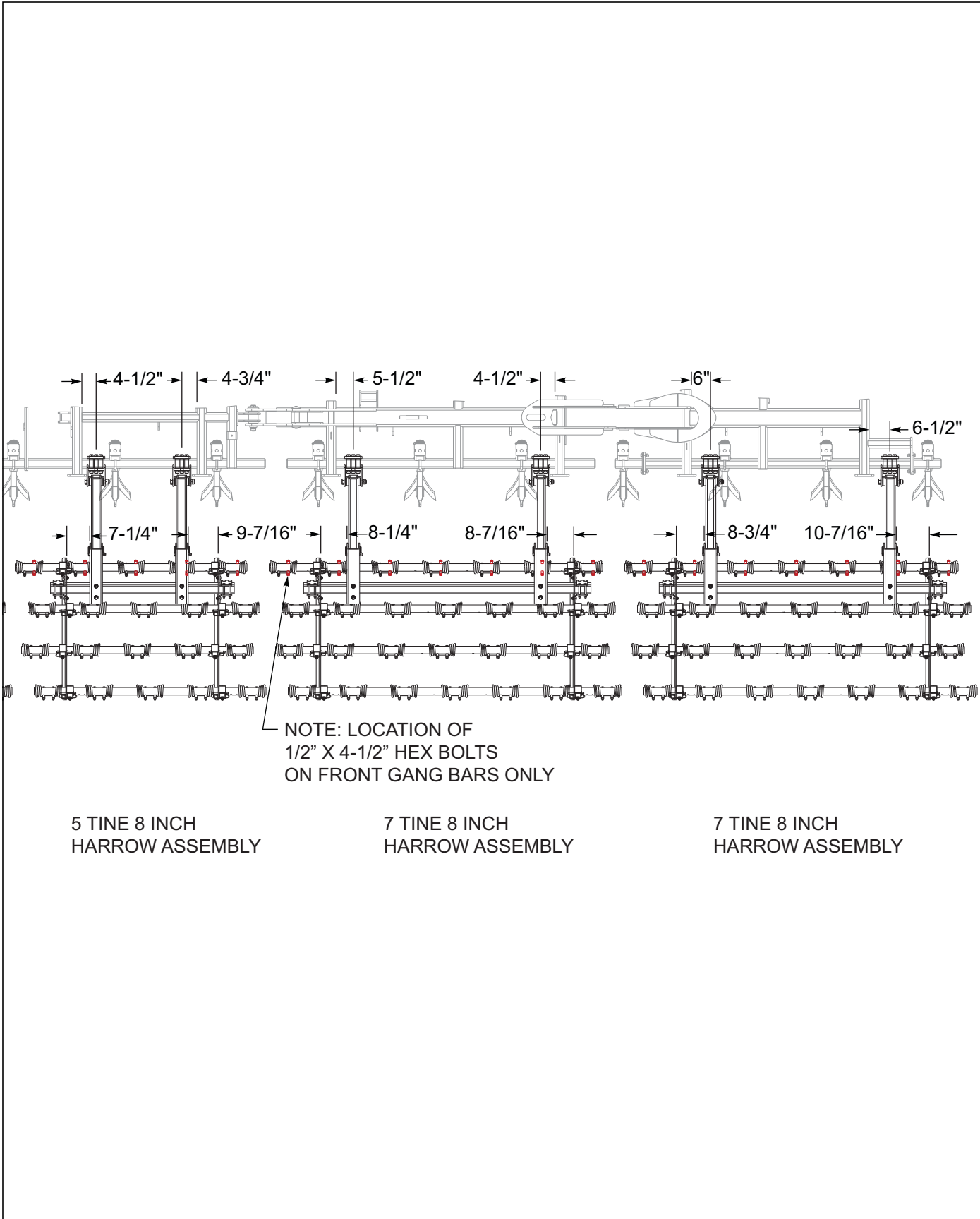

Figure 2-12: 4 Row CT Placement 8550-48' RH

3 Row Tine & Reel Placement

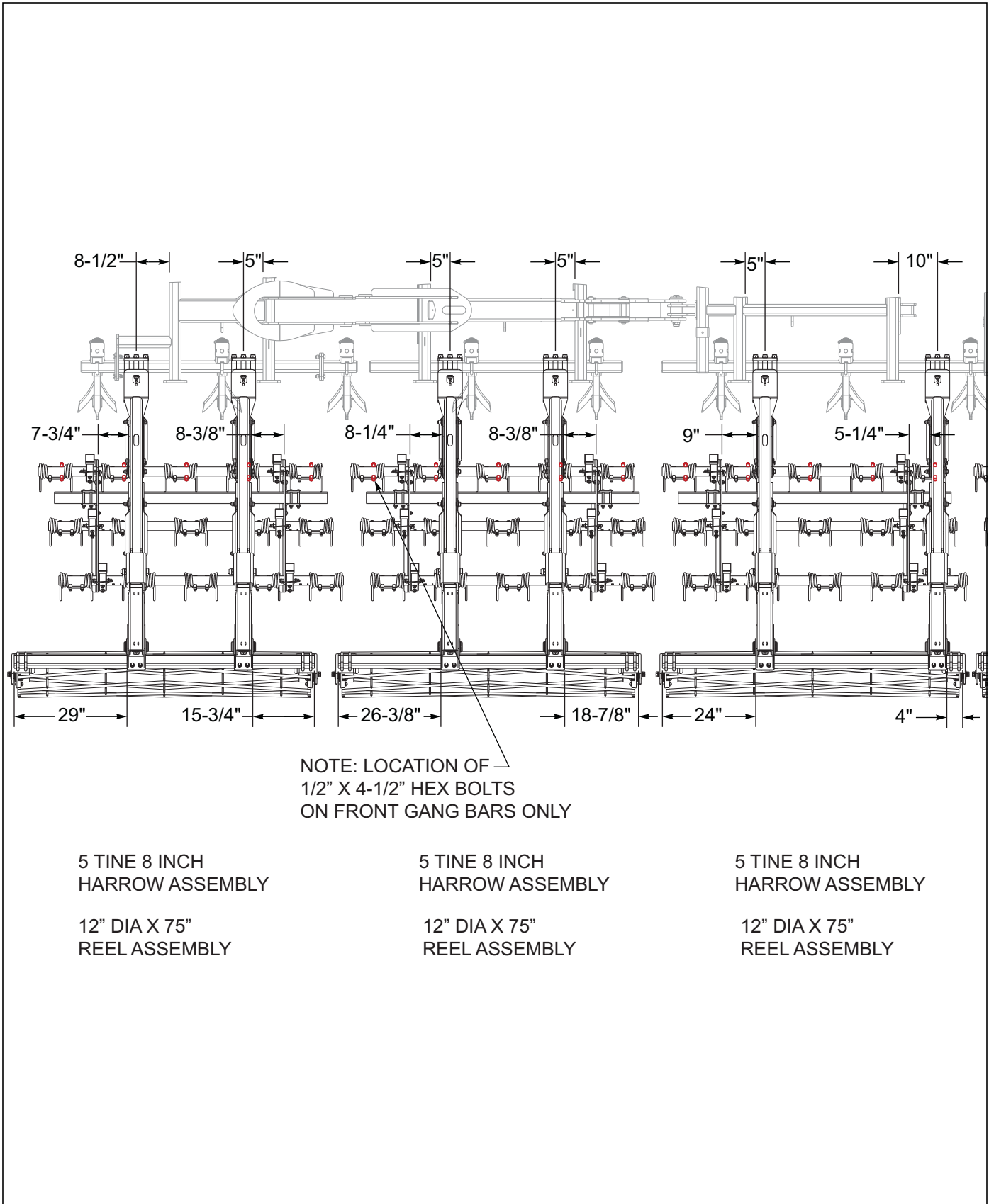

Figure 2-13: 3 Row Tine & Reel Placement 8550-38' LH

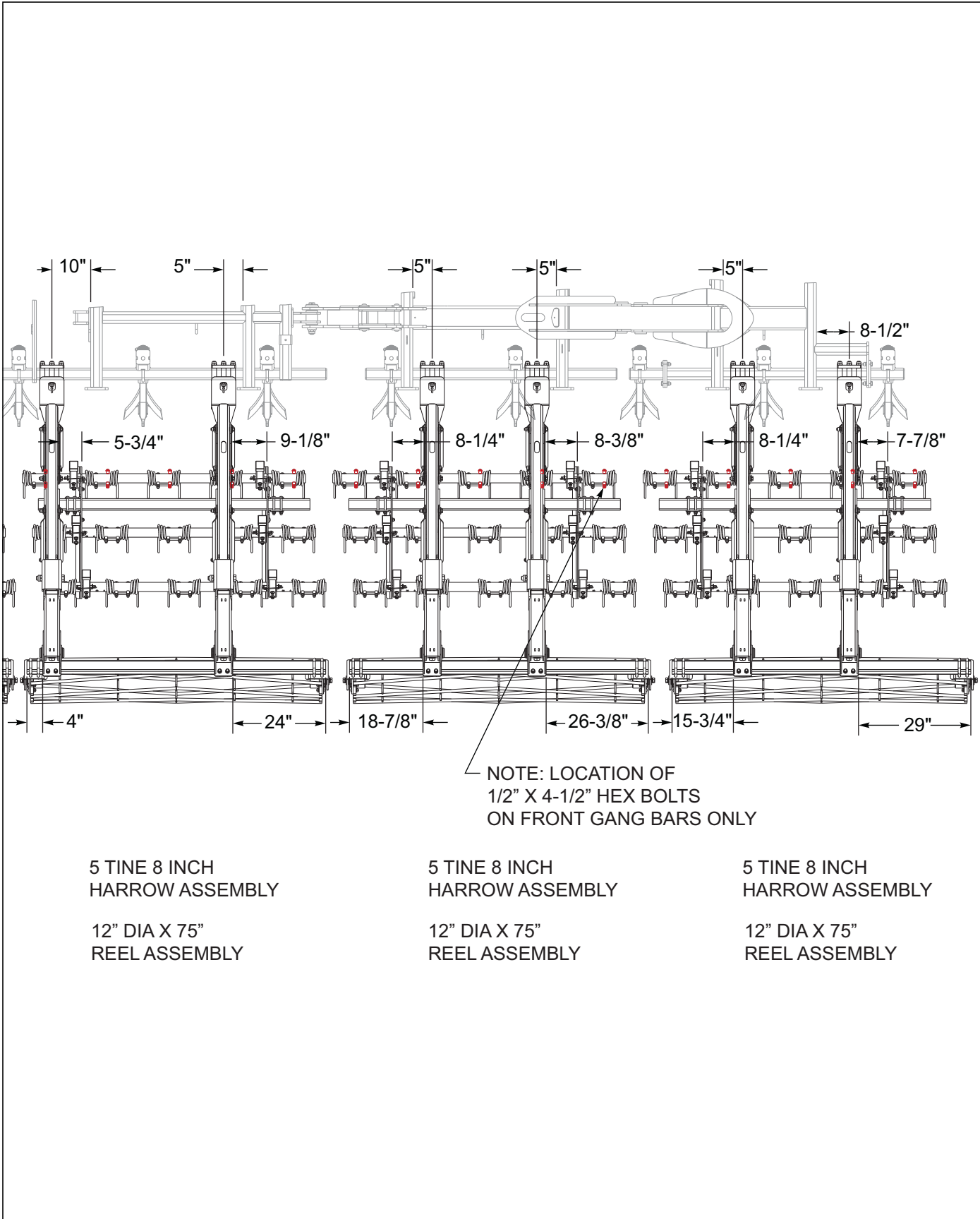

Figure 2-14: 3 Row Tine & Reel Placement 8550-38' RH

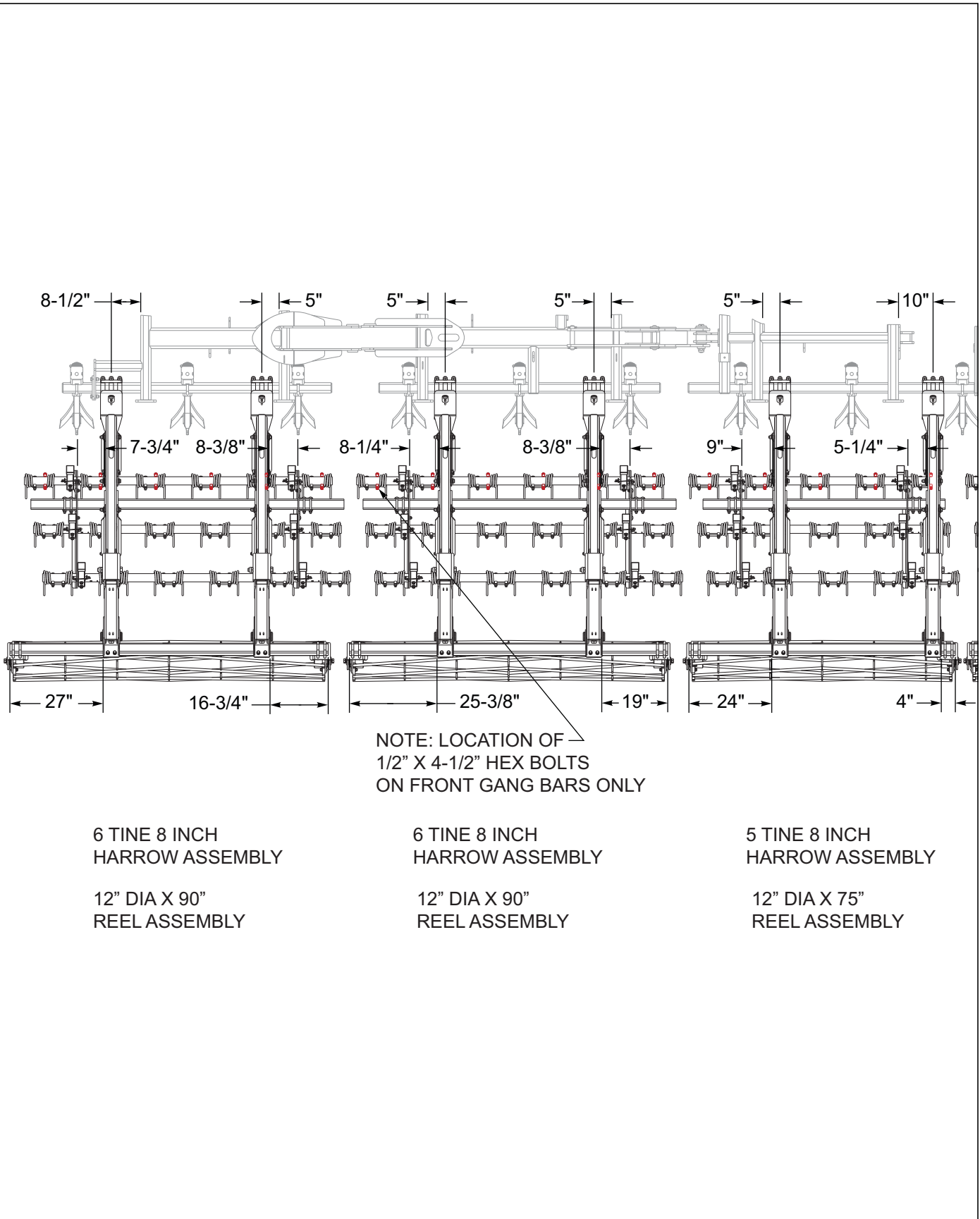

Figure 2-15: 3 Row Tine & Reel Placement 8550-43' LH

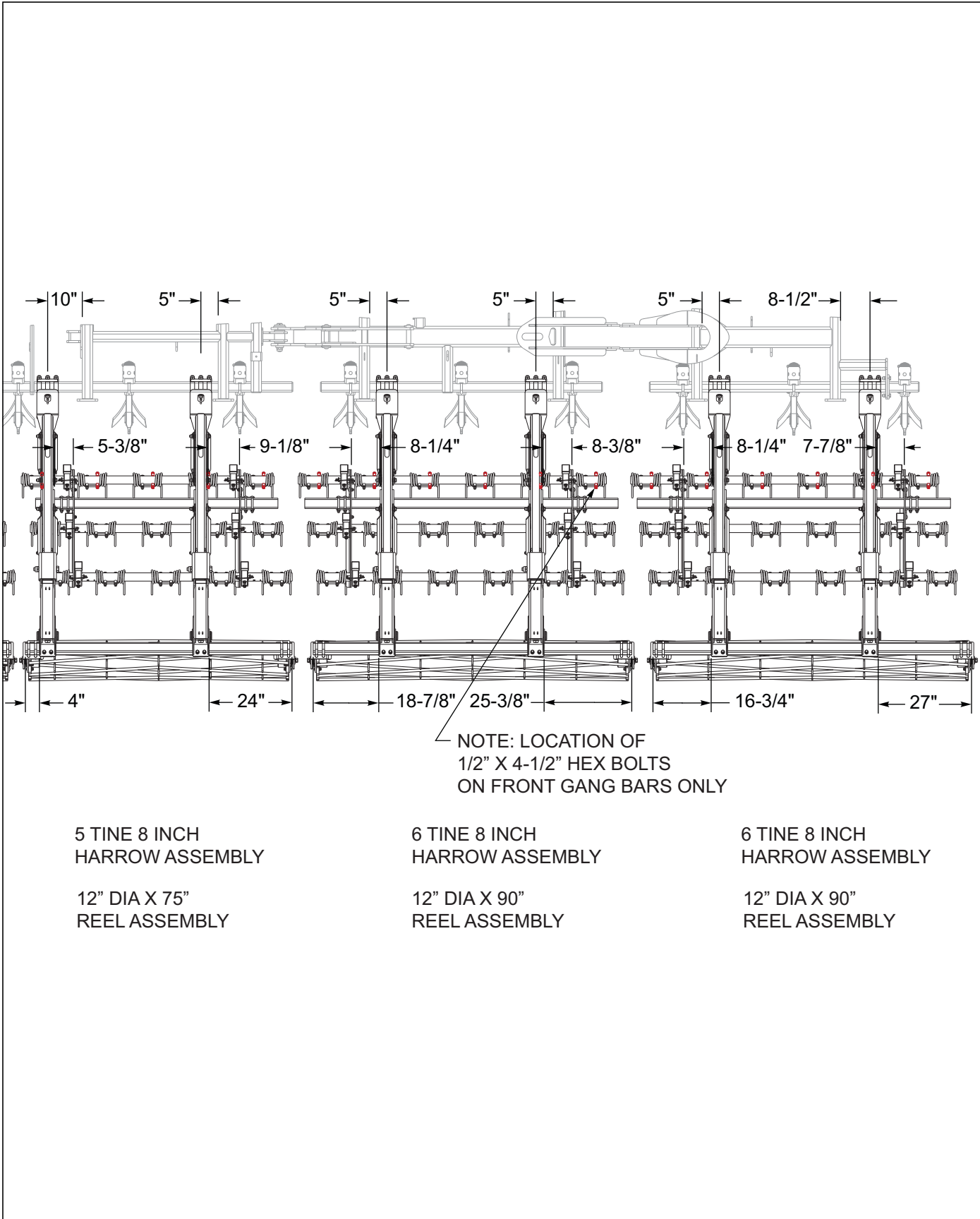

Figure 2-16: 3 Row Tine & Reel Placement 8550-43' RH

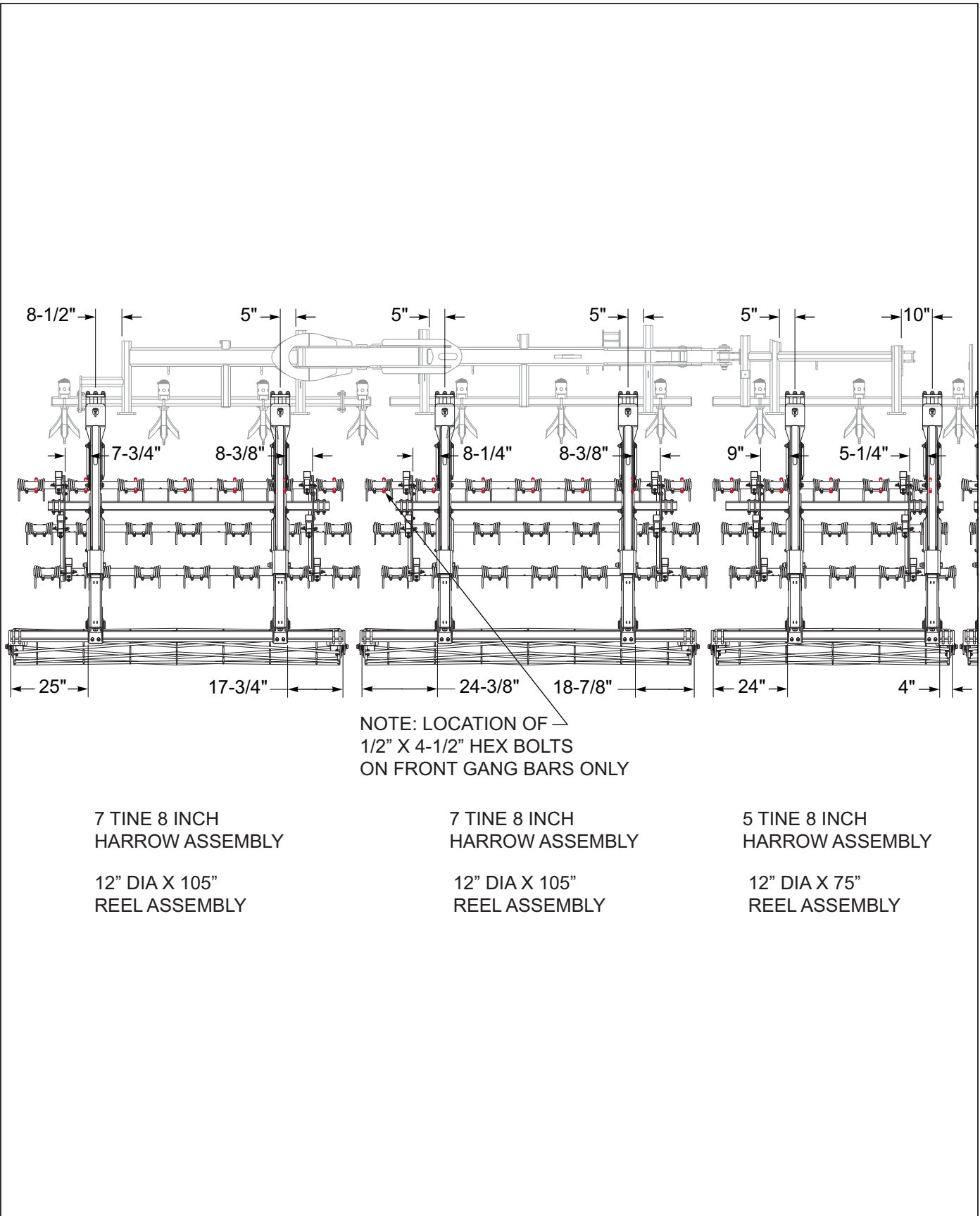

Figure 2-17: 3 Row Tine & Reel Placement 8550-48' LH

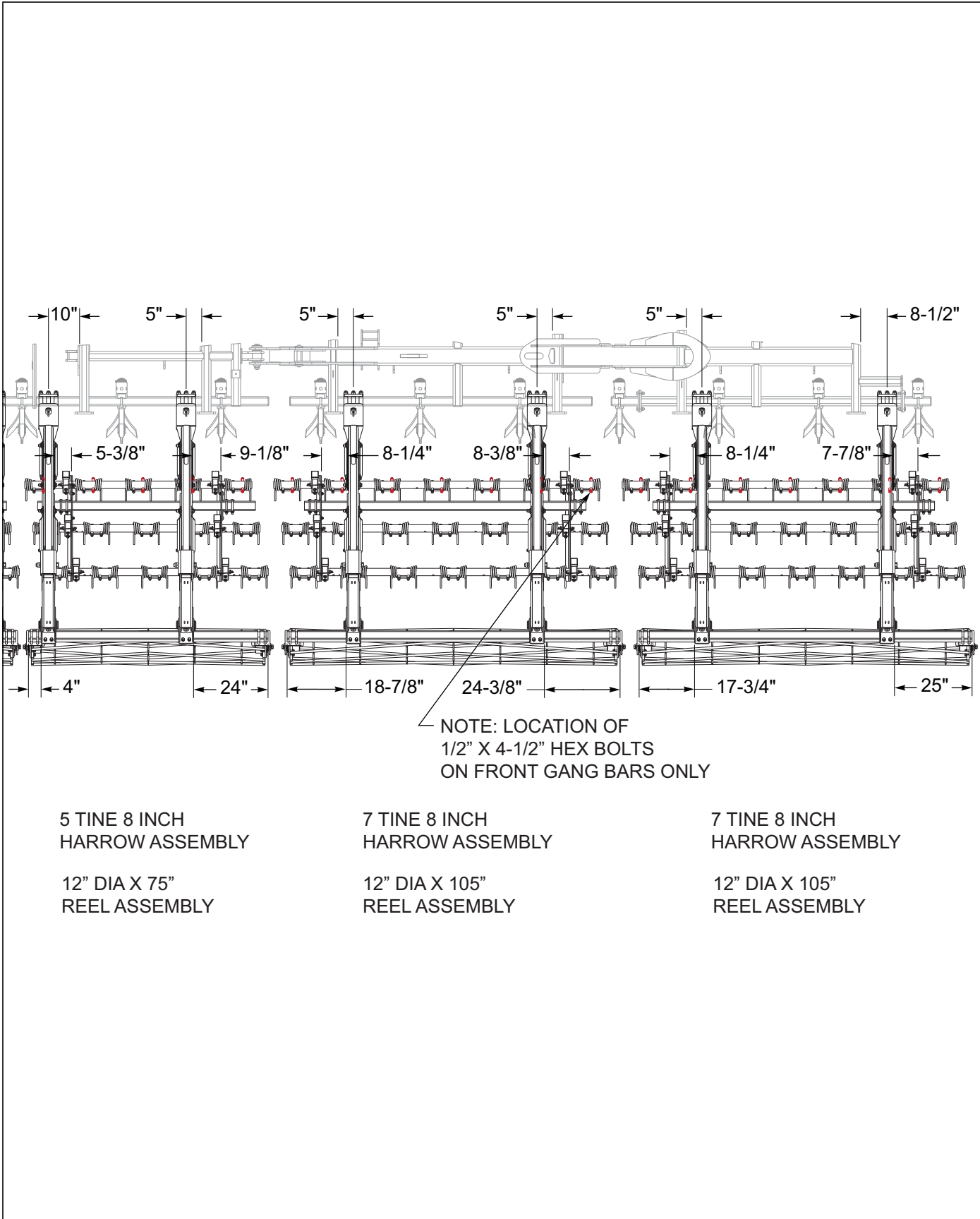

Figure 2-18: 3 Row Tine & Reel Placement 8550-48' RH

5 Row Spike Placement

** DENOTES USE OF
BAR CLAMP W/TABS
(P/N 186200)

NOTE: FOR PROPER SPIKE HARROW PLACEMENT.
BE SURE TO COUNT BOTH ROUND AND SQUARE
SPIKE HOLES.
CATCH TRAYS POINT INWARD, HOOKS POINT
OUTWARD.

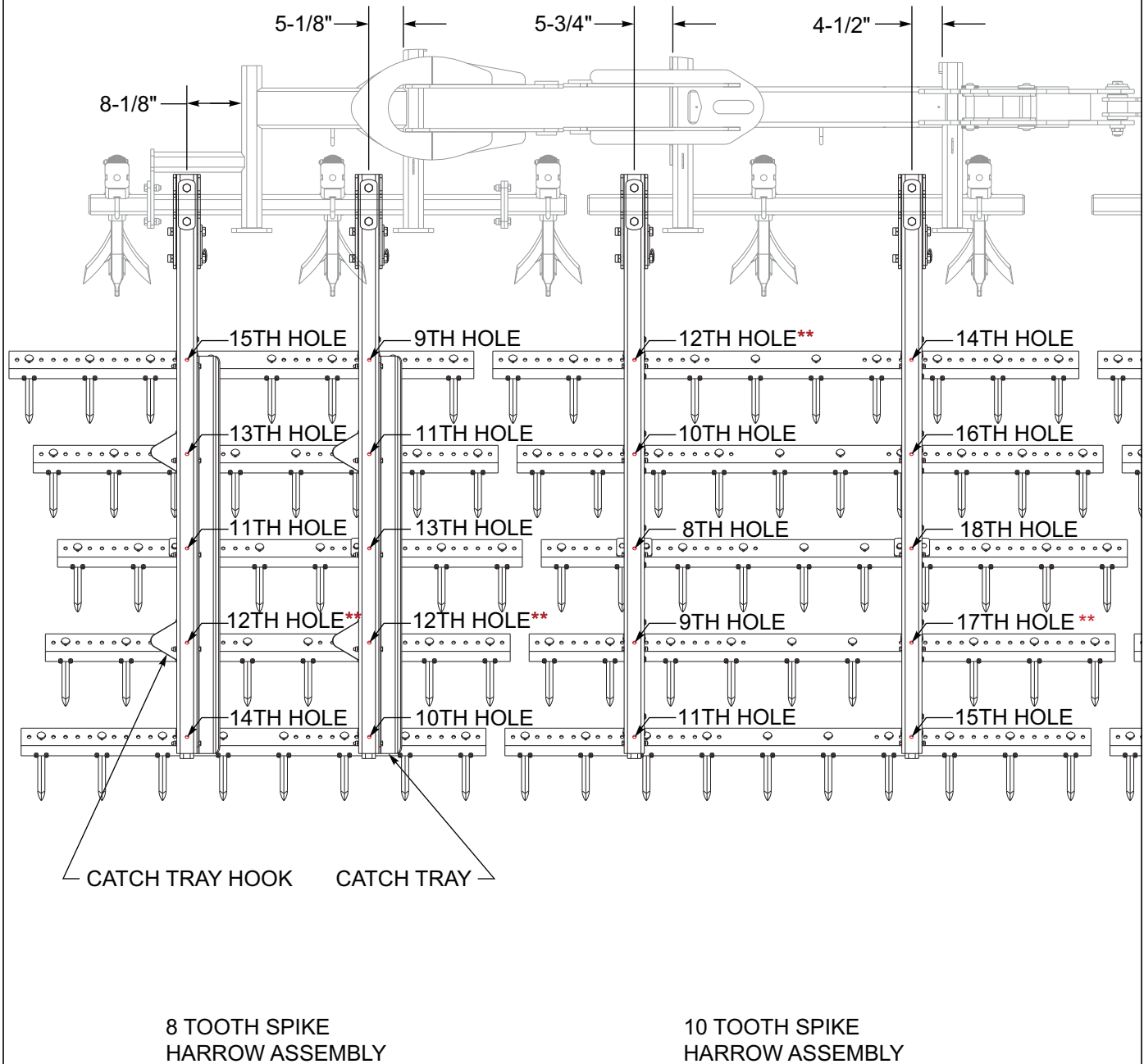

Figure 2-19: 5 Row Spike Placement 8550-38' LH

** DENOTES USE OF
BAR CLAMP W/TABS
(P/N 186200)

NOTE: FOR PROPER SPIKE HARROW PLACEMENT.
BE SURE TO COUNT BOTH ROUND AND SQUARE
SPIKE HOLES.
CATCH TRAYS POINT INWARD, HOOKS POINT
OUTWARD.

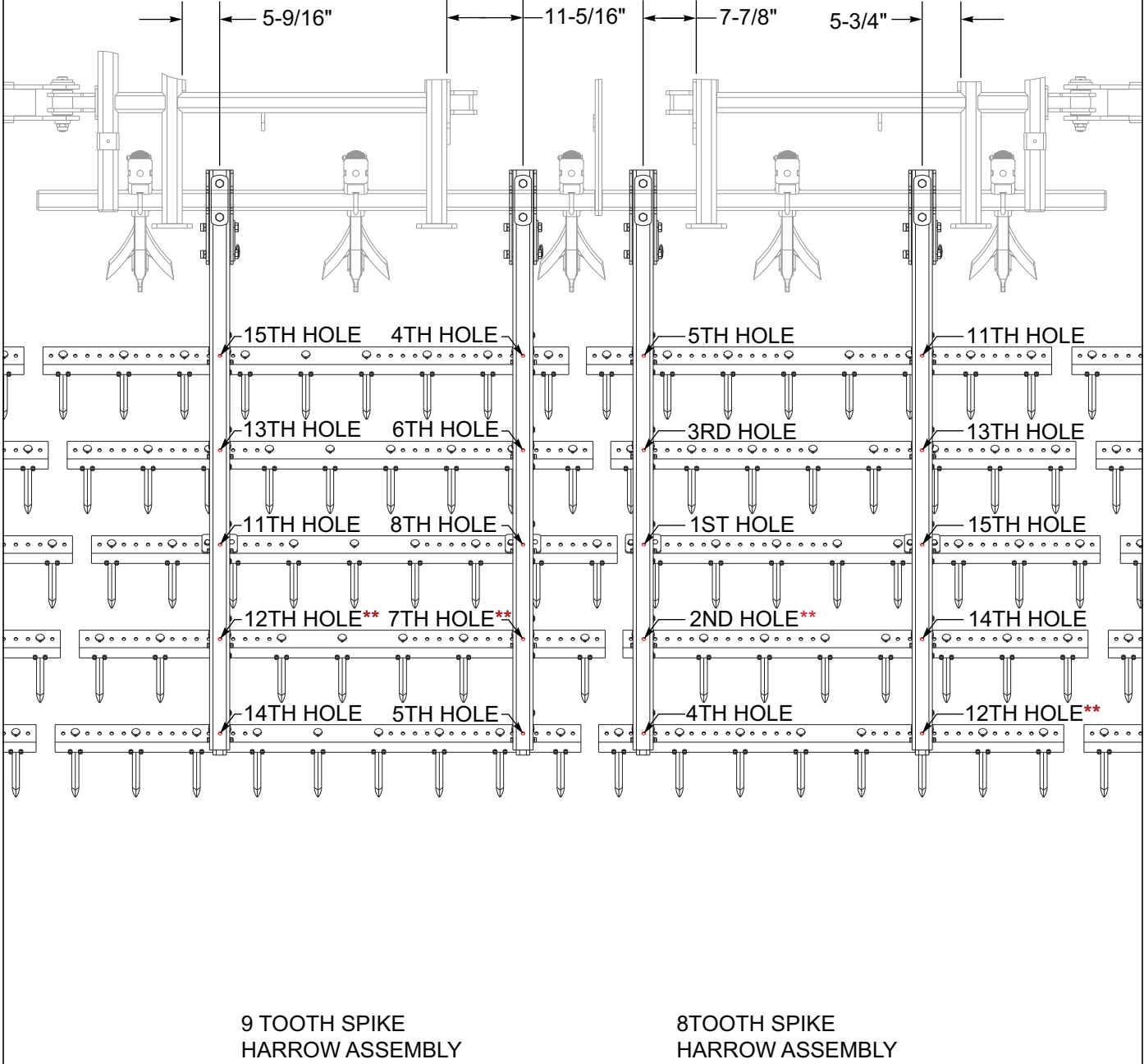

Figure 2-20: 5 Row Spike Placement 8550-38' MIDDLE

STANDARD SPECIFICATIONS

** DENOTES USE OF
BAR CLAMP W/TABS
(P/N 186200)

NOTE: FOR PROPER SPIKE HARROW PLACEMENT,
BE SURE TO COUNT BOTH ROUND AND SQUARE
SPIKE HOLES.
CATCH TRAYS POINT INWARD, HOOKS POINT
OUTWARD.

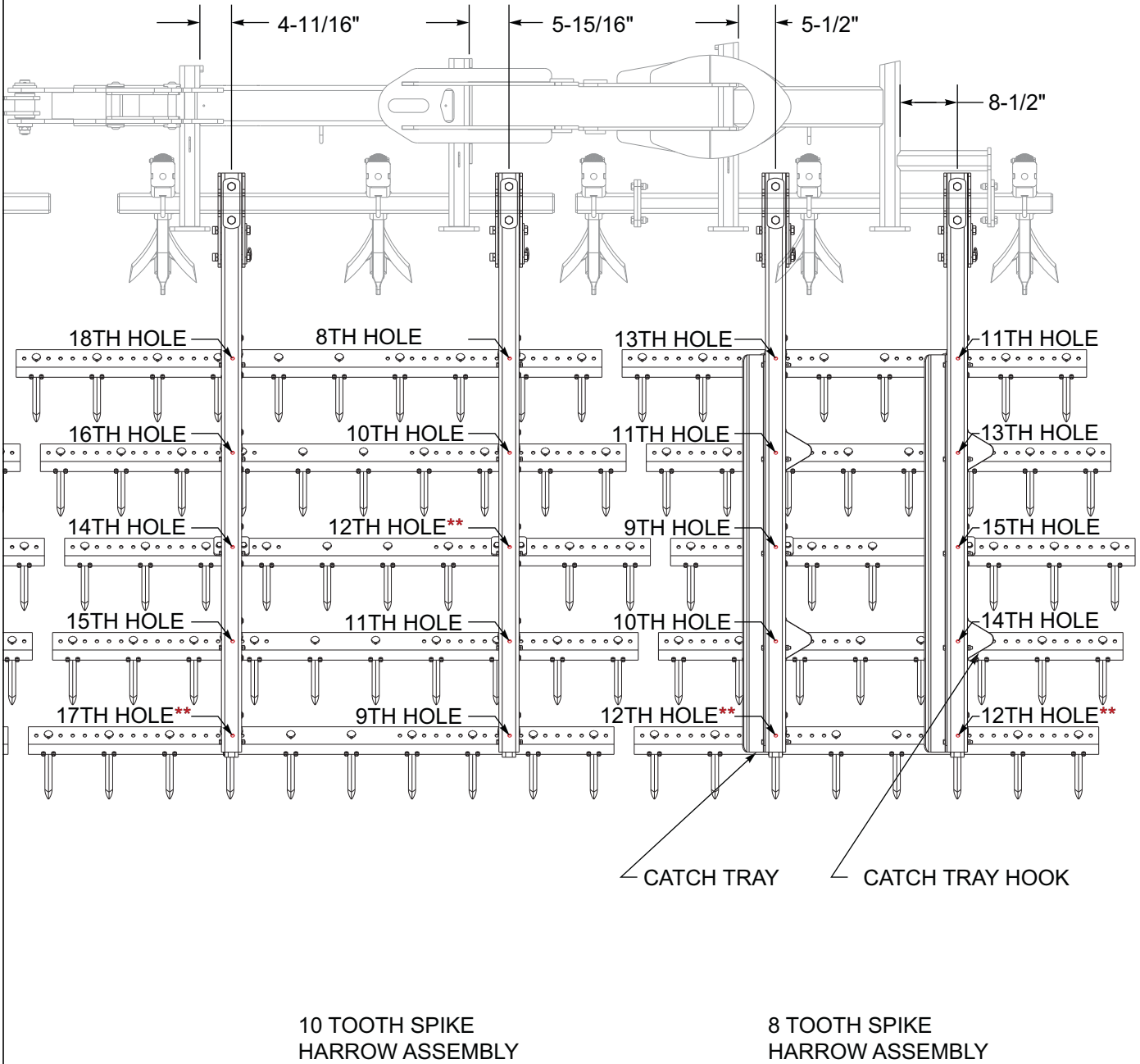

Figure 2-21: 5 Row Spike Placement 8550-38' RH

** DENOTES USE OF BAR CLAMP W/TABS (P/N 186200)

NOTE: FOR PROPER SPIKE HARROW PLACEMENT. BE SURE TO COUNT BOTH ROUND AND SQUARE SPIKE HOLES. CATCH TRAYS POINT INWARD, HOOKS POINT OUTWARD.

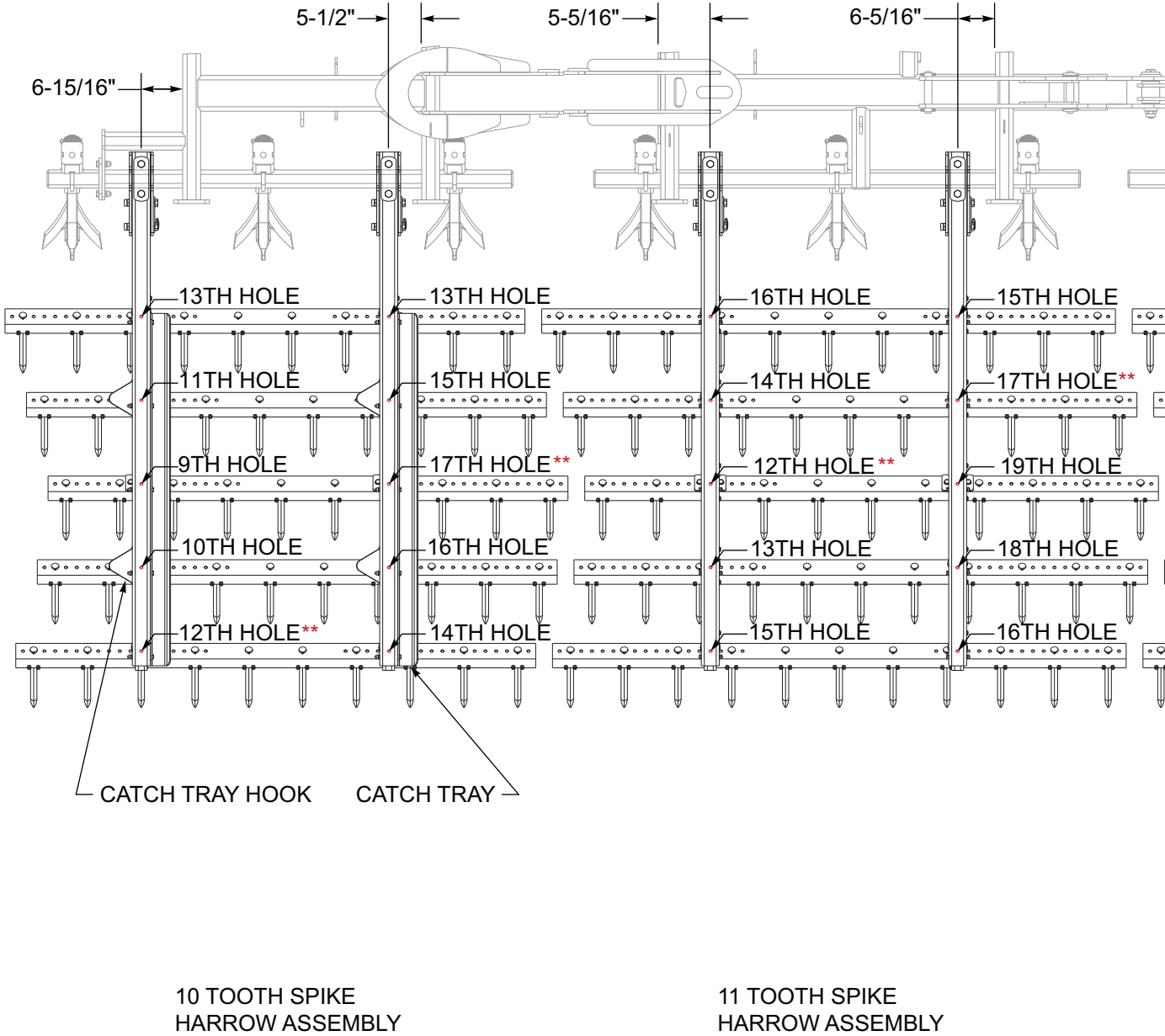

Figure 2-22: 5 Row Spike Placement 8550-43' LH

STANDARD SPECIFICATIONS

** DENOTES USE OF
BAR CLAMP W/TABS
(P/N 186200)

NOTE: FOR PROPER SPIKE HARROW PLACEMENT.
BE SURE TO COUNT BOTH ROUND AND SQUARE
SPIKE HOLES.
CATCH TRAYS POINT INWARD, HOOKS POINT
OUTWARD.

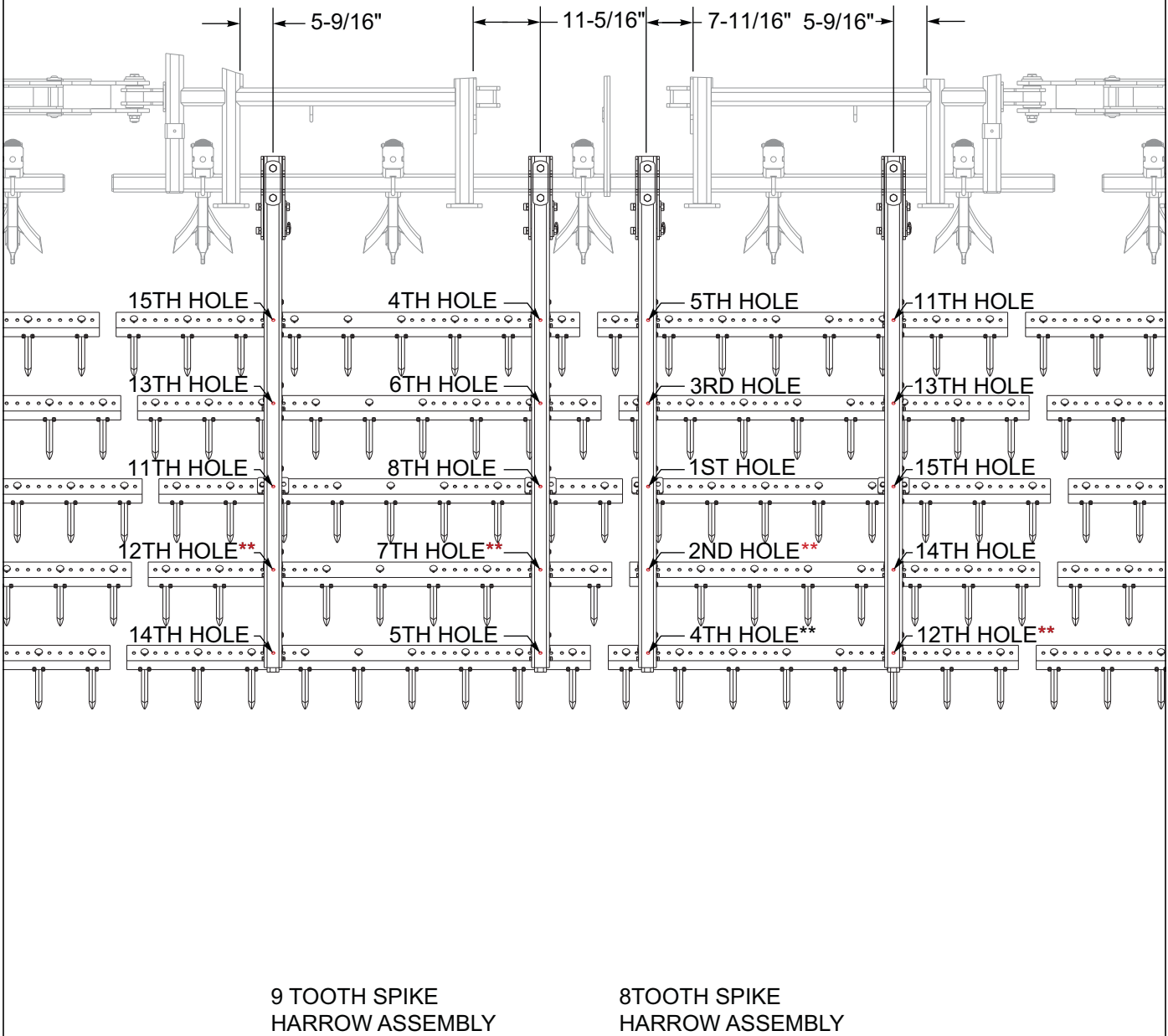

Figure 2-23: 5 Row Spike Placement 8550-43' MIDDLE

** DENOTES USE OF
BAR CLAMP W/TABS
(P/N 186200)

NOTE: FOR PROPER SPIKE HARROW PLACEMENT.
BE SURE TO COUNT BOTH ROUND AND SQUARE
SPIKE HOLES.
CATCH TRAYS POINT INWARD, HOOKS POINT
OUTWARD.

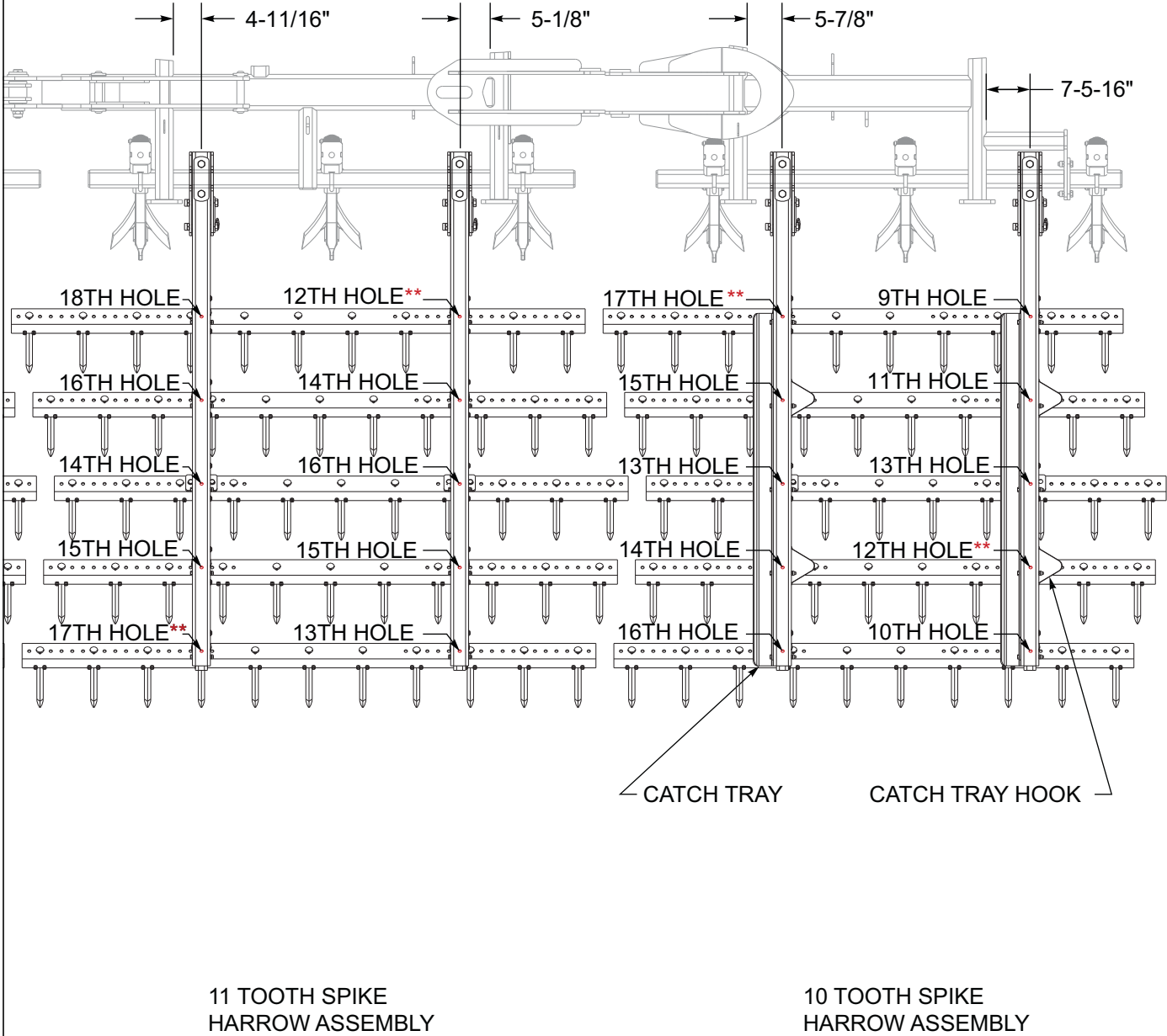

Figure 2-24: 5 Row Spike Placement 8550-43' RH

STANDARD SPECIFICATIONS

** DENOTES USE OF
BAR CLAMP W/TABS
(P/N 186200)

NOTE: FOR PROPER SPIKE HARROW PLACEMENT,
BE SURE TO COUNT BOTH ROUND AND SQUARE
SPIKE HOLES.
CATCH TRAYS POINT INWARD, HOOKS POINT
OUTWARD.

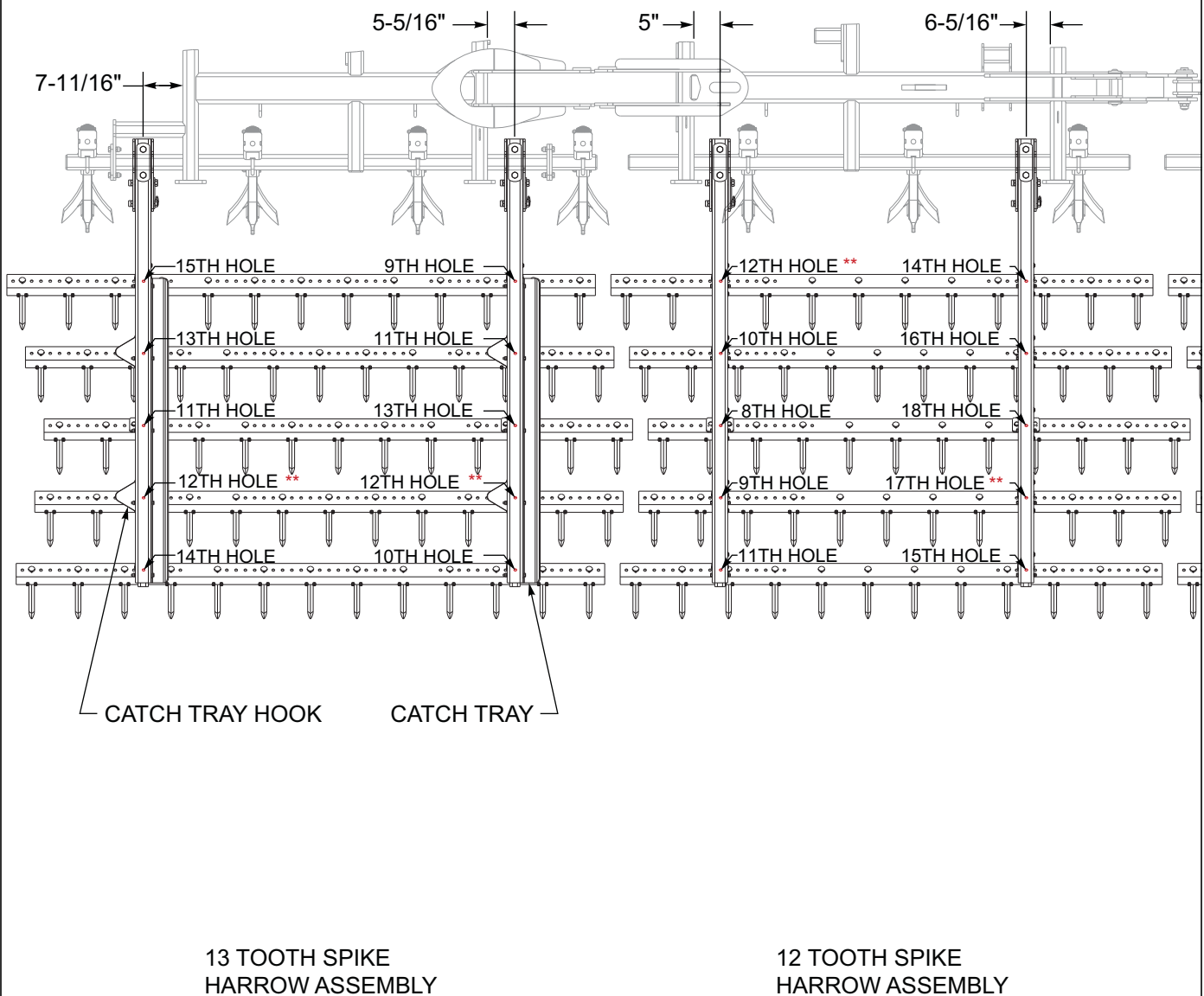

Figure 2-25: 5 Row Spike Placement 8550-48' LH

** DENOTES USE OF
BAR CLAMP W/TABS
(P/N 186200)

NOTE: FOR PROPER SPIKE HARROW PLACEMENT.
BE SURE TO COUNT BOTH ROUND AND SQUARE
SPIKE HOLES.
CATCH TRAYS POINT INWARD, HOOKS POINT
OUTWARD.

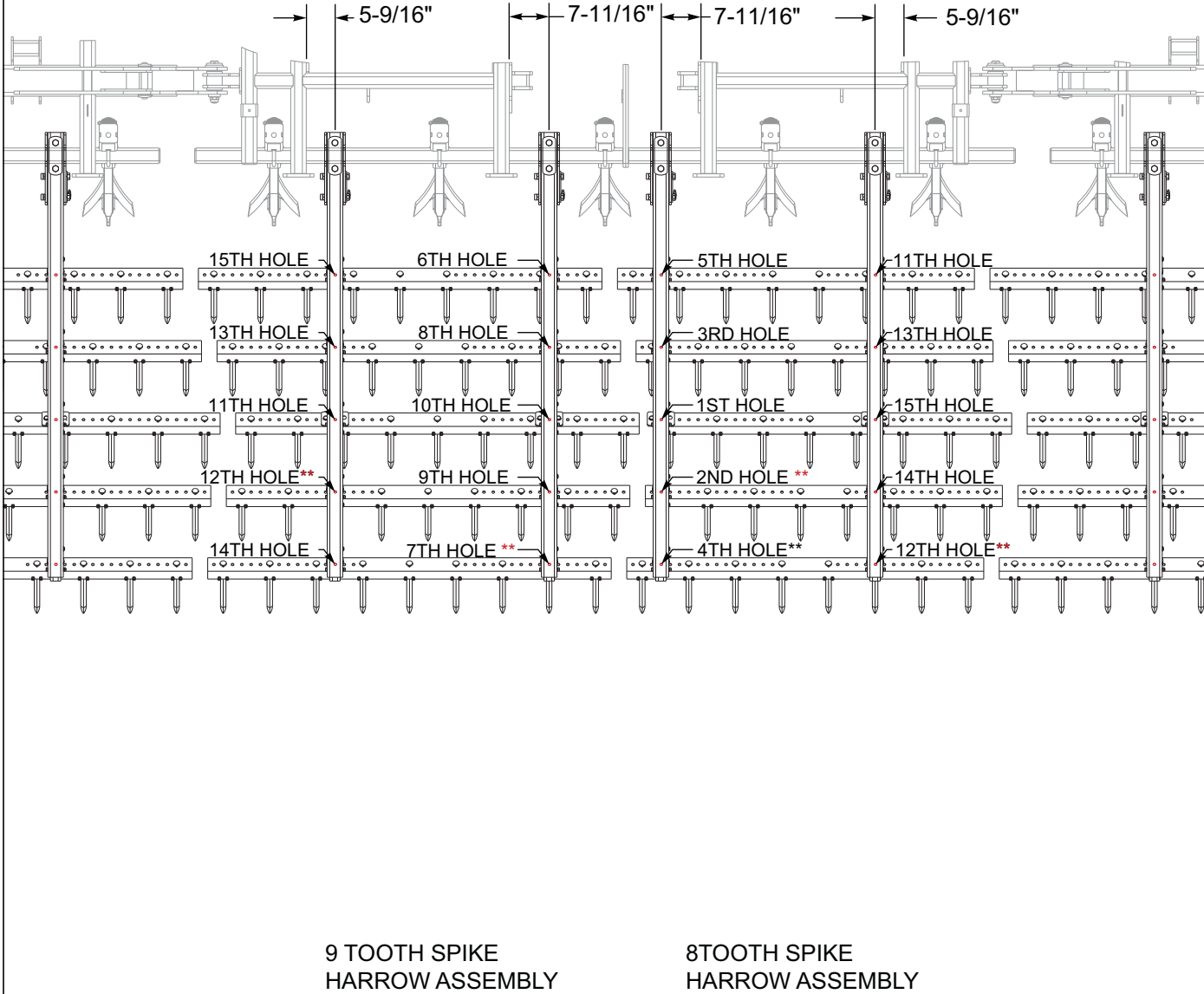

Figure 2-26: 5 Row Spike Placement 8550-48' MIDDLE

STANDARD SPECIFICATIONS

** DENOTES USE OF
BAR CLAMP W/TABS
(P/N 186200)

NOTE: FOR PROPER SPIKE HARROW PLACEMENT.
BE SURE TO COUNT BOTH ROUND AND SQUARE
SPIKE HOLES.
CATCH TRAYS POINT INWARD, HOOKS POINT
OUTWARD.

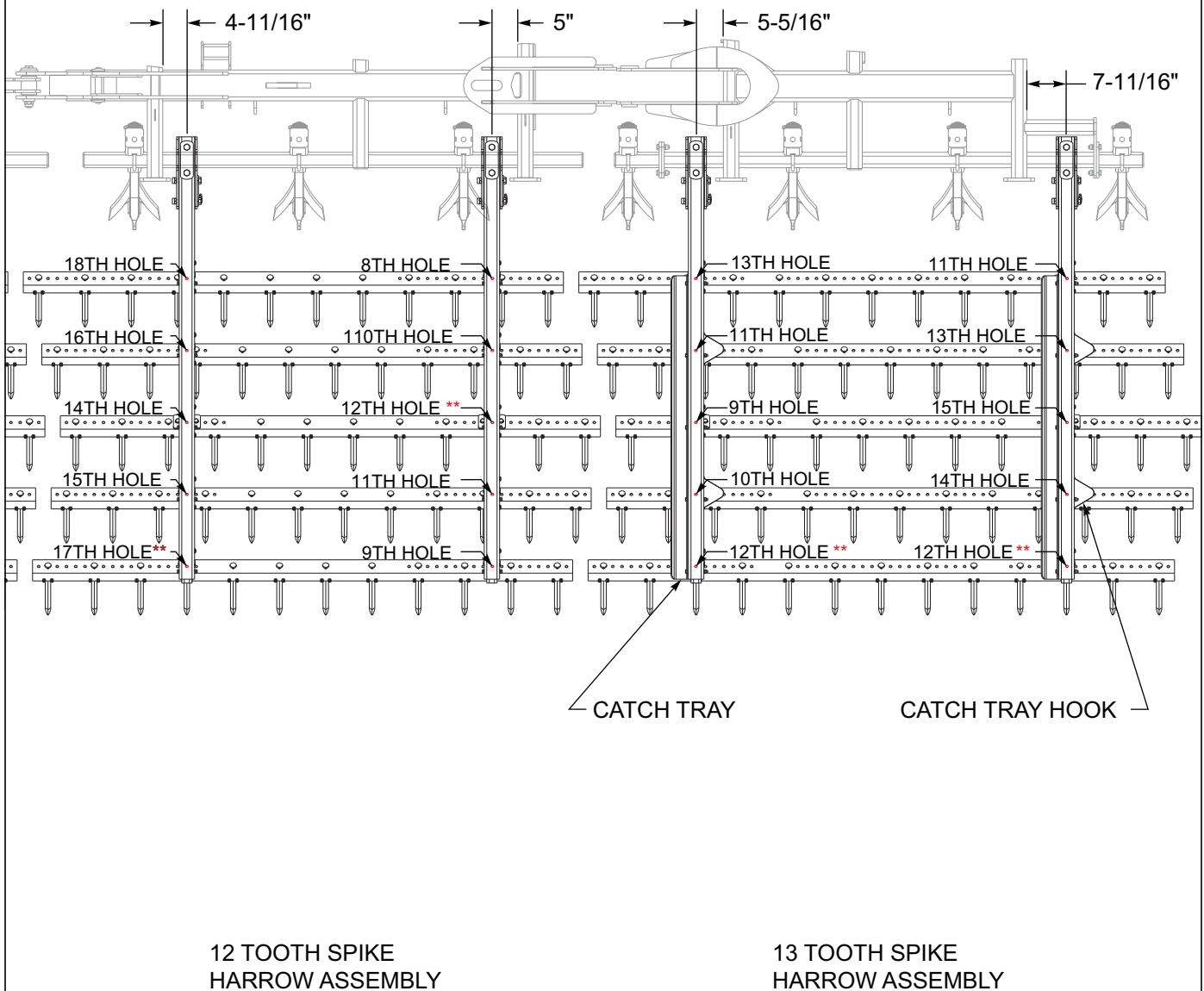

Figure 2-27: 5 Row Spike Placement 8550-48' RH

3 Row Spike & Reel Placement

** DENOTES USE OF
BAR CLAMP W/TABS
(P/N 186200)

NOTE: FOR PROPER SPIKE HARROW PLACEMENT.
BE SURE TO COUNT BOTH ROUND AND SQUARE
SPIKE HOLES.

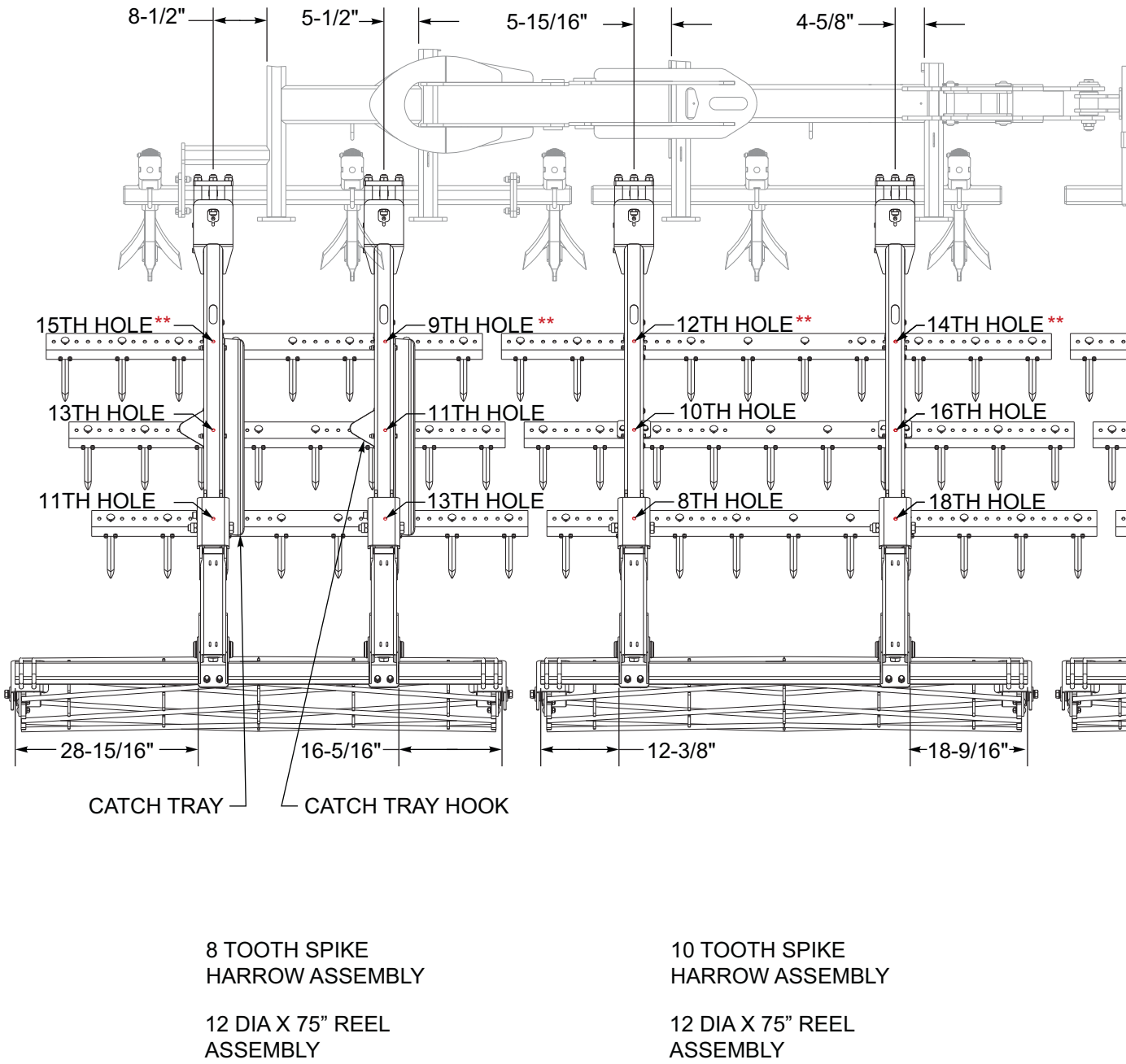
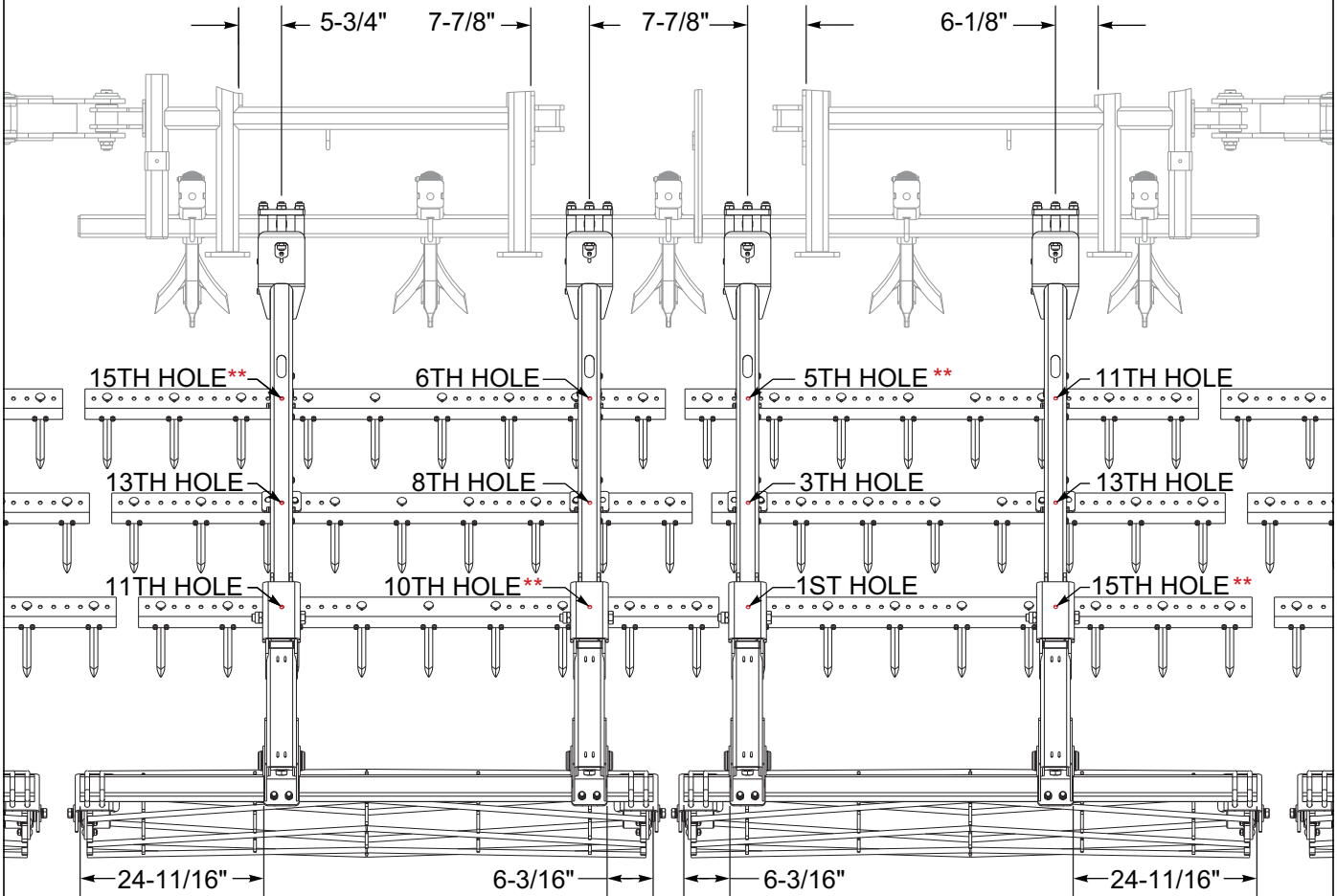

Figure 2-28: 3 Row Spike & Reel Placement 8550-38' LH

STANDARD SPECIFICATIONS

** DENOTES USE OF
BAR CLAMP W/TABS
(P/N 186200)

NOTE: FOR PROPER SPIKE HARROW PLACEMENT,
BE SURE TO COUNT BOTH ROUND AND SQUARE
SPIKE HOLES.



9 TOOTH SPIKE
HARROW ASSEMBLY

12 DIA X 75" REEL
ASSEMBLY

8 TOOTH SPIKE
HARROW ASSEMBLY

12 DIA X 75" REEL
ASSEMBLY

Figure 2-29: 3 Row Spike & Reel Placement 8550-38' MIDDLE

** DENOTES USE OF BAR CLAMP W/TABS (P/N 186200)

NOTE: FOR PROPER SPIKE HARROW PLACEMENT BE SURE TO COUNT BOTH ROUND AND SQUARE SPIKE HOLES.

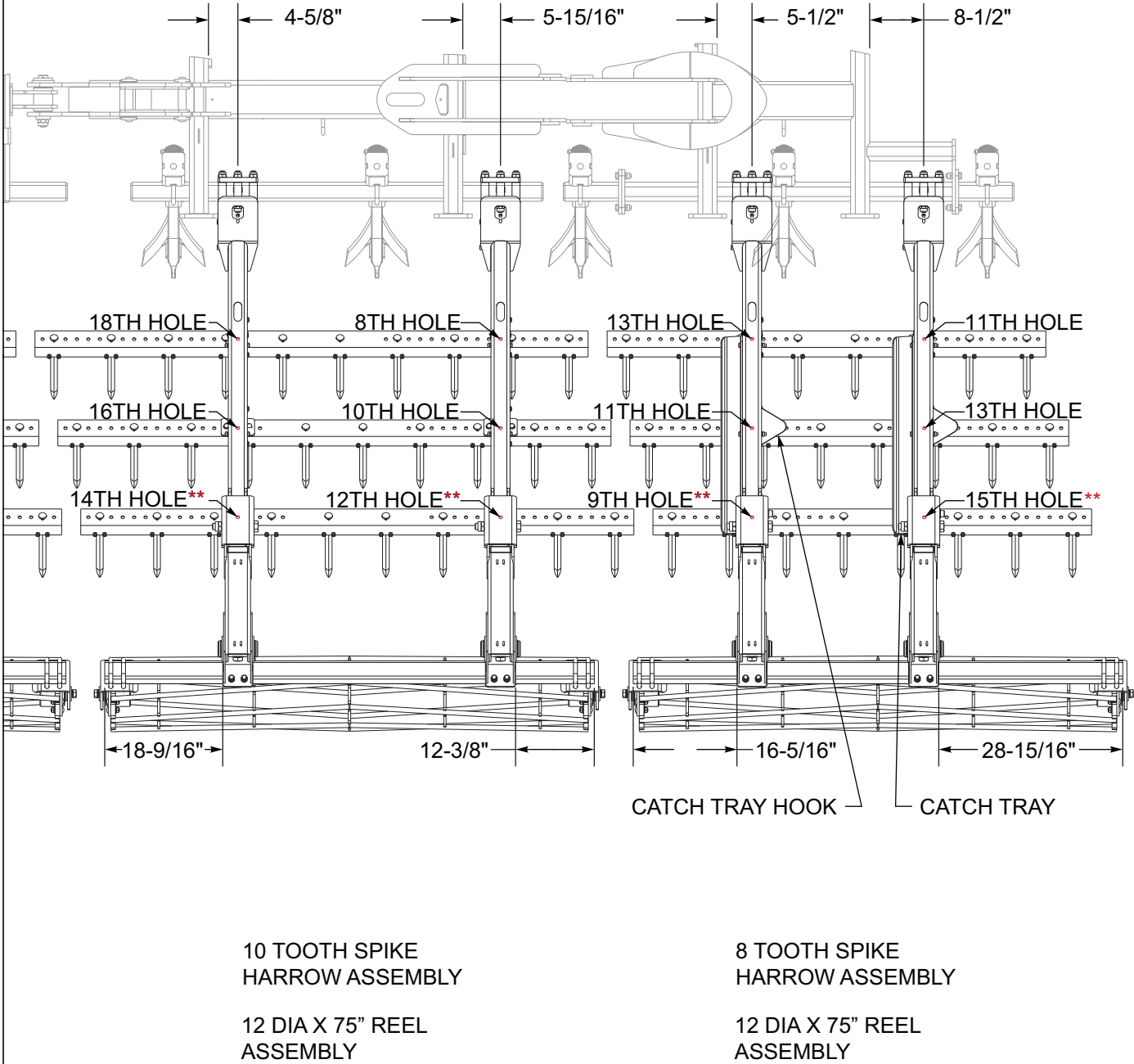

Figure 2-30: 3 Row Spike & Reel Placement 8550-38' RH

STANDARD SPECIFICATIONS

** DENOTES USE OF
BAR CLAMP W/TABS
(P/N 186200)

NOTE: FOR PROPER SPIKE HARROW PLACEMENT,
BE SURE TO COUNT BOTH ROUND AND SQUARE
SPIKE HOLES.

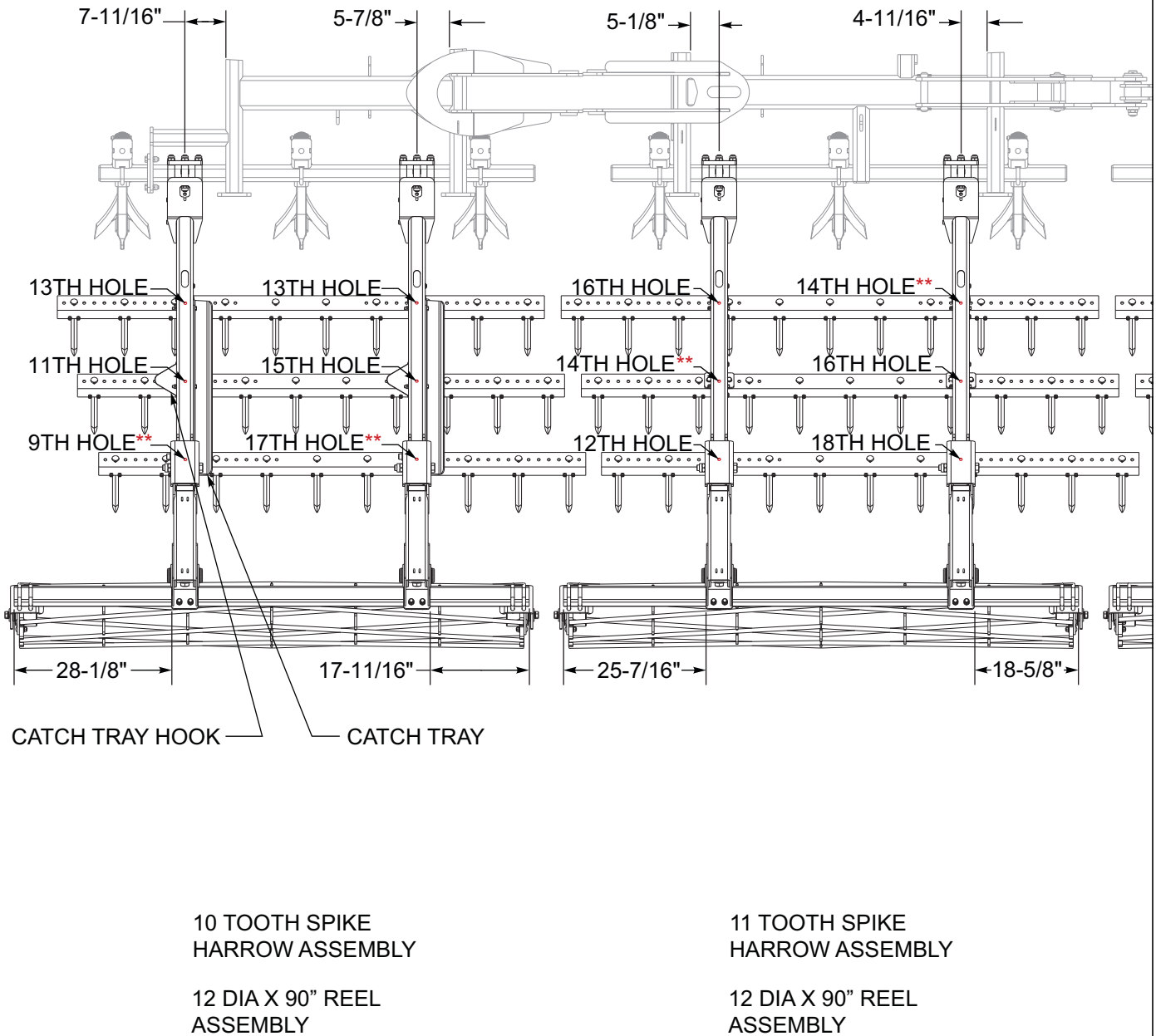
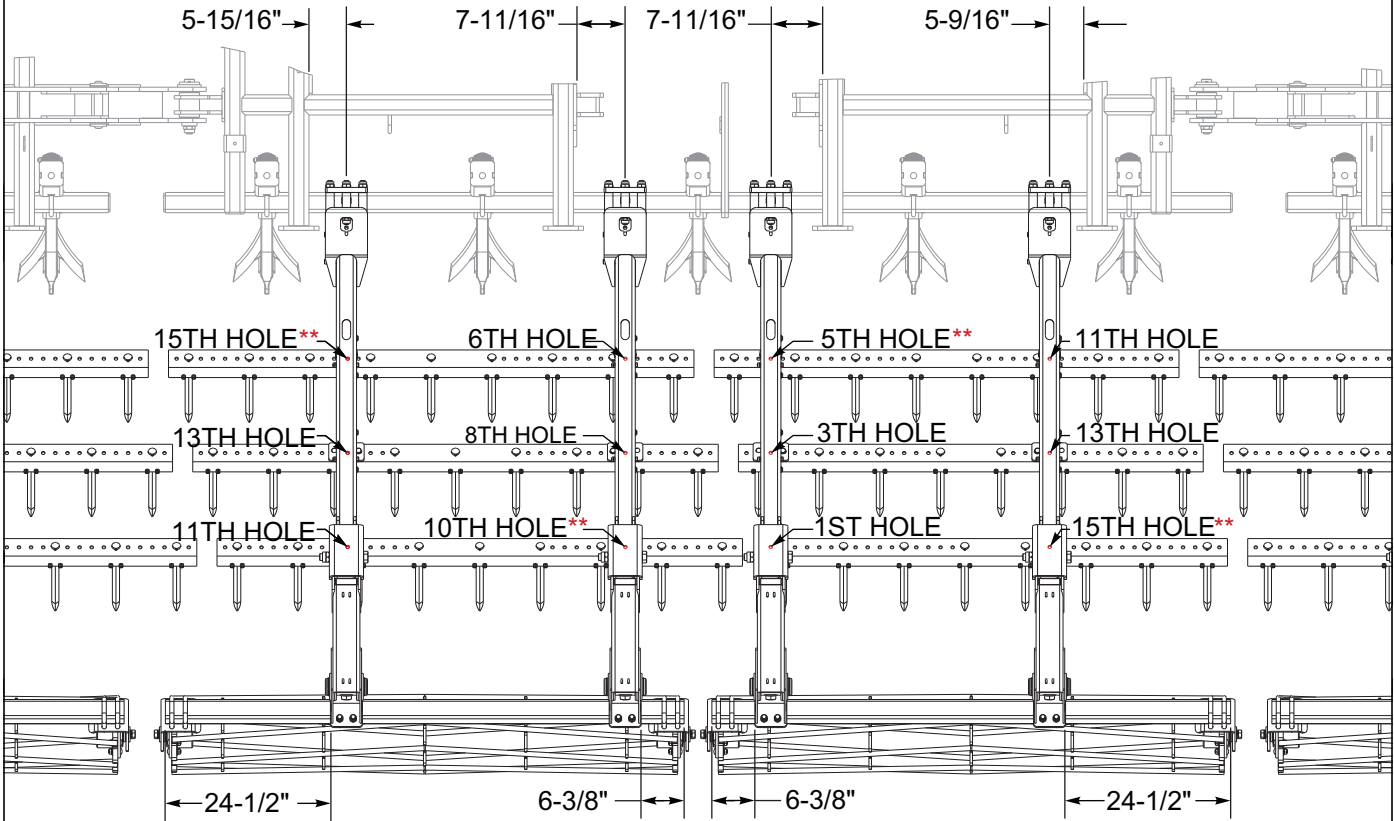

Figure 2-31: 3 Row Spike & Reel Placement 8550-43' LH

** DENOTES USE OF
BAR CLAMP W/TABS
(P/N 186200)

NOTE: FOR PROPER SPIKE HARROW PLACEMENT,
BE SURE TO COUNT BOTH ROUND AND SQUARE
SPIKE HOLES.



9 TOOTH SPIKE
HARROW ASSEMBLY

8 TOOTH SPIKE
HARROW ASSEMBLY

12 DIA X 75" REEL
ASSEMBLY

12 DIA X 75" REEL
ASSEMBLY

Figure 2-32: 3 Row Spike & Reel Placement 8550-43' MIDDLE

STANDARD SPECIFICATIONS

** DENOTES USE OF
BAR CLAMP W/TABS
(P/N 186200)

NOTE: FOR PROPER SPIKE HARROW PLACEMENT,
BE SURE TO COUNT BOTH ROUND AND SQUARE
SPIKE HOLES.

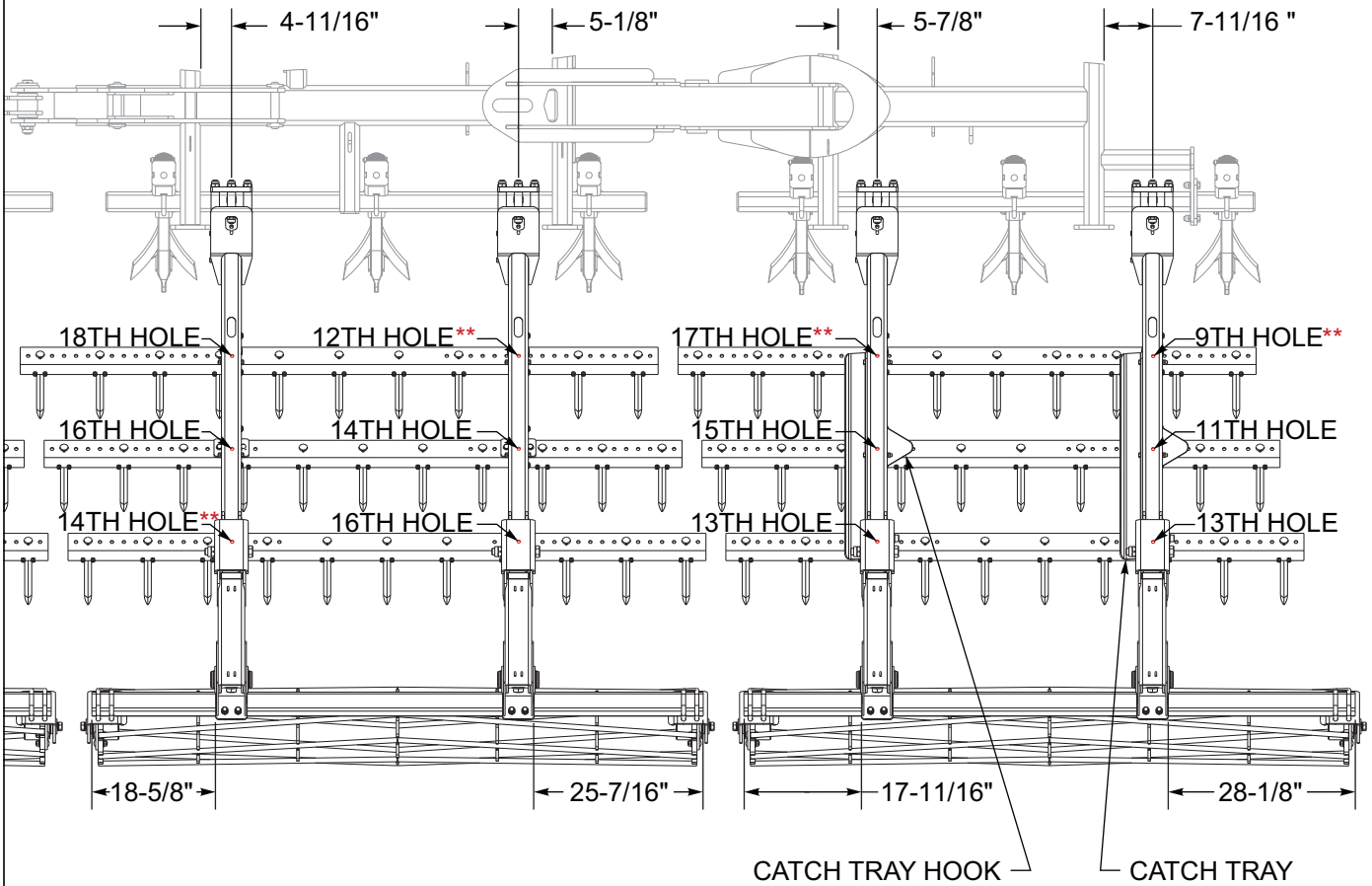

11 TOOTH SPIKE
HARROW ASSEMBLY

12 DIA X 90" REEL
ASSEMBLY

10 TOOTH SPIKE
HARROW ASSEMBLY

12 DIA X 90" REEL
ASSEMBLY

Figure 2-33: 3 Row Spike & Reel Placement 8550-4' RH

** DENOTES USE OF
BAR CLAMP W/TABS
(P/N 186200)

NOTE: FOR PROPER SPIKE HARROW PLACEMENT.
BE SURE TO COUNT BOTH ROUND AND SQUARE
SPIKE HOLES.

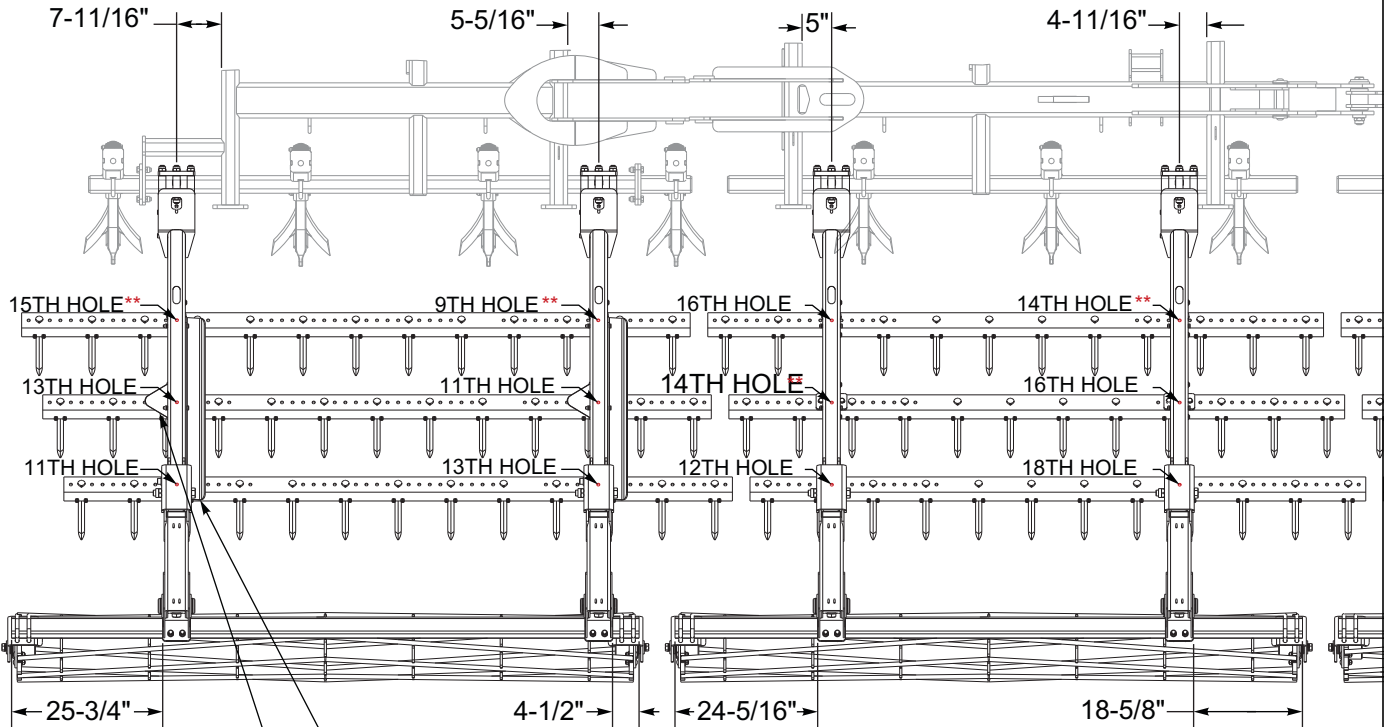

CATCH TRAY HOOK — CATCH TRAY

13 TOOTH SPIKE
HARROW ASSEMBLY

12 DIA X 105" REEL
ASSEMBLY

12 TOOTH SPIKE
HARROW ASSEMBLY

12 DIA X 105" REEL
ASSEMBLY

Figure 2-34: 3 Row Spike & Reel Placement 8550-48' LH

STANDARD SPECIFICATIONS

** DENOTES USE OF
BAR CLAMP W/TABS
(P/N 186200)

NOTE: FOR PROPER SPIKE HARROW PLACEMENT,
BE SURE TO COUNT BOTH ROUND AND SQUARE
SPIKE HOLES.

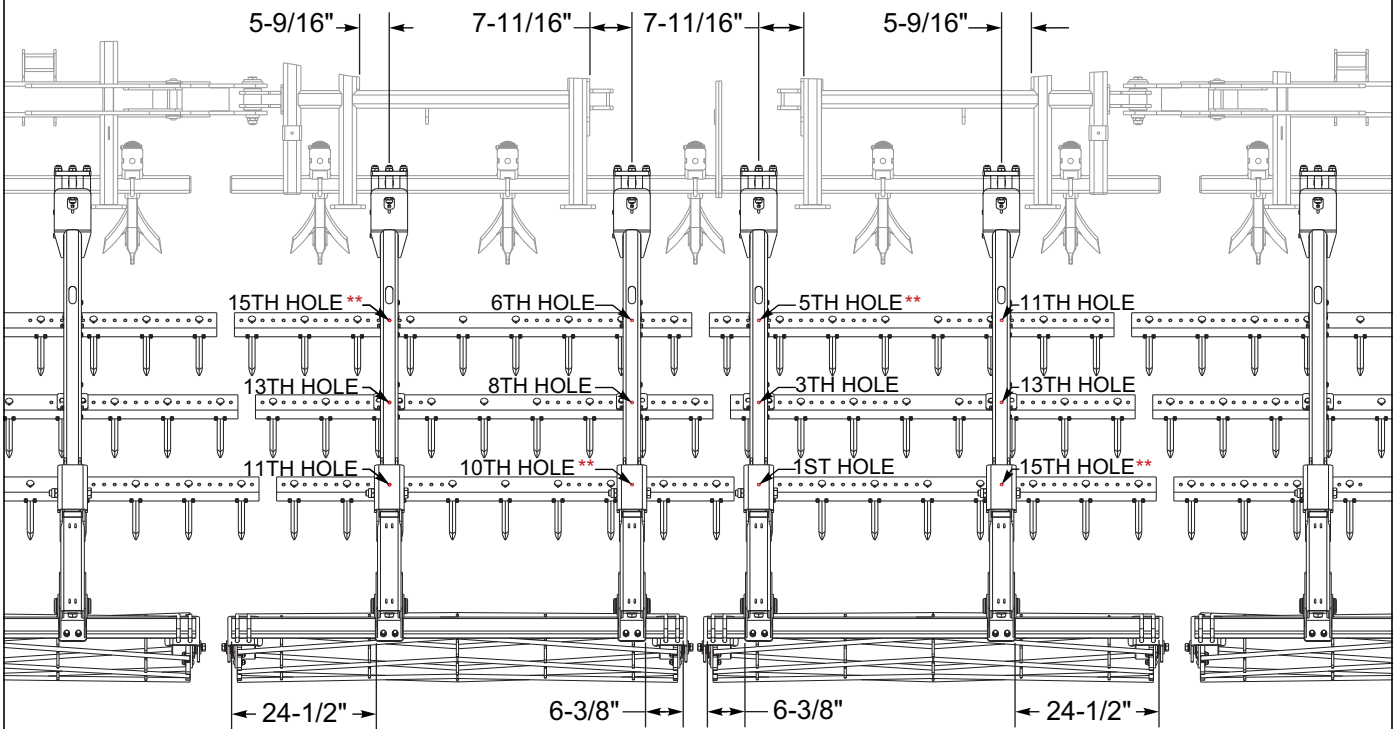

9 TOOTH SPIKE
HARROW ASSEMBLY

12 DIA X 75" REEL
ASSEMBLY

8 TOOTH SPIKE
HARROW ASSEMBLY

12 DIA X 75" REEL
ASSEMBLY

Figure 2-35: 3 Row Spike & Reel Placement 8550-48' MIDDLE

** DENOTES USE OF
BAR CLAMP W/TABS
(P/N 186200)

NOTE: FOR PROPER SPIKE HARROW PLACEMENT,
BE SURE TO COUNT BOTH ROUND AND SQUARE
SPIKE HOLES.

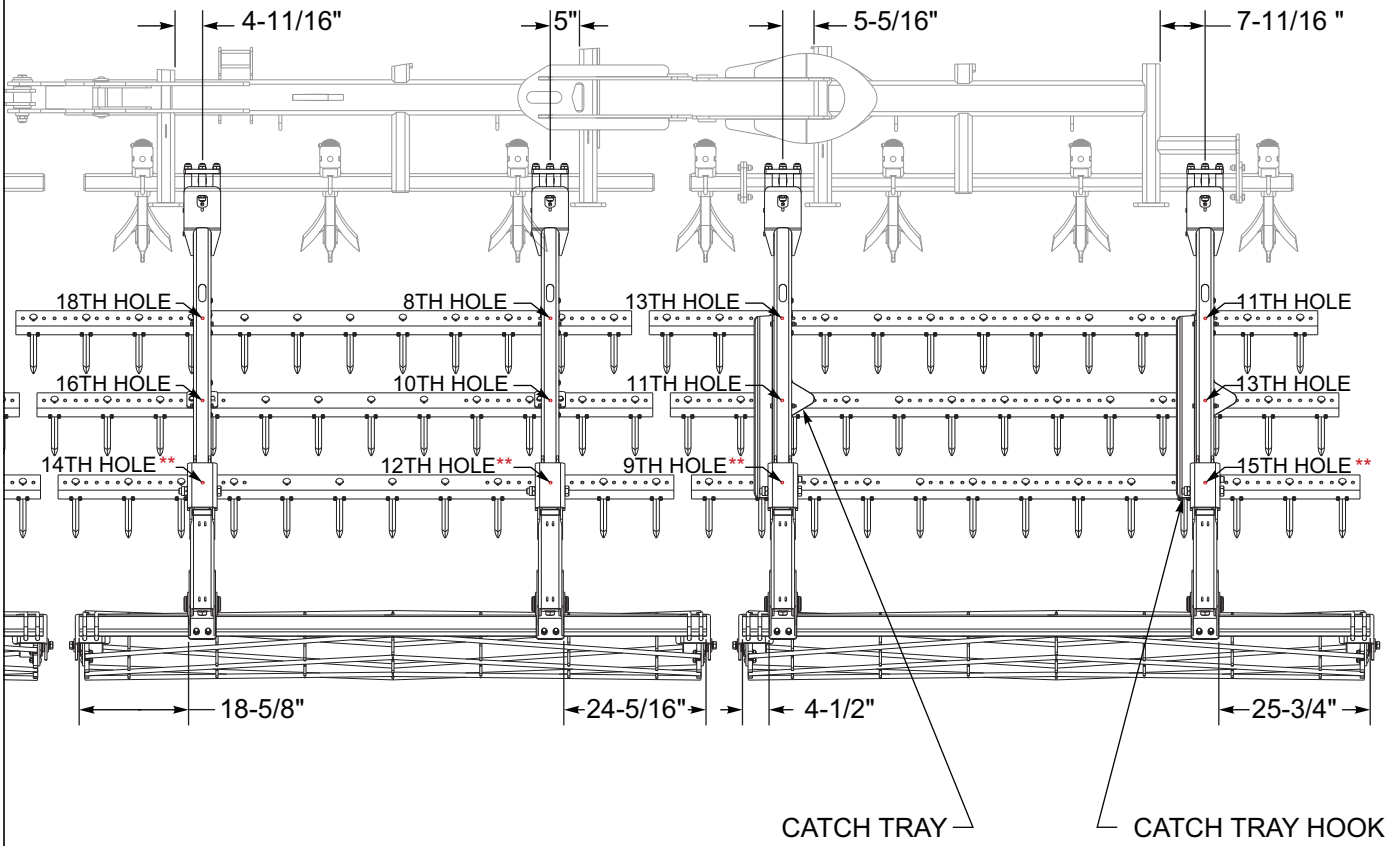

12 TOOTH SPIKE
HARROW ASSEMBLY

12 DIA X 105" REEL
ASSEMBLY

13 TOOTH SPIKE
HARROW ASSEMBLY

12 DIA X 105" REEL
ASSEMBLY

Figure 2-36: 3 Row Spike & Reel Placement 8550-48' RH

Spike & Double Reel Placement

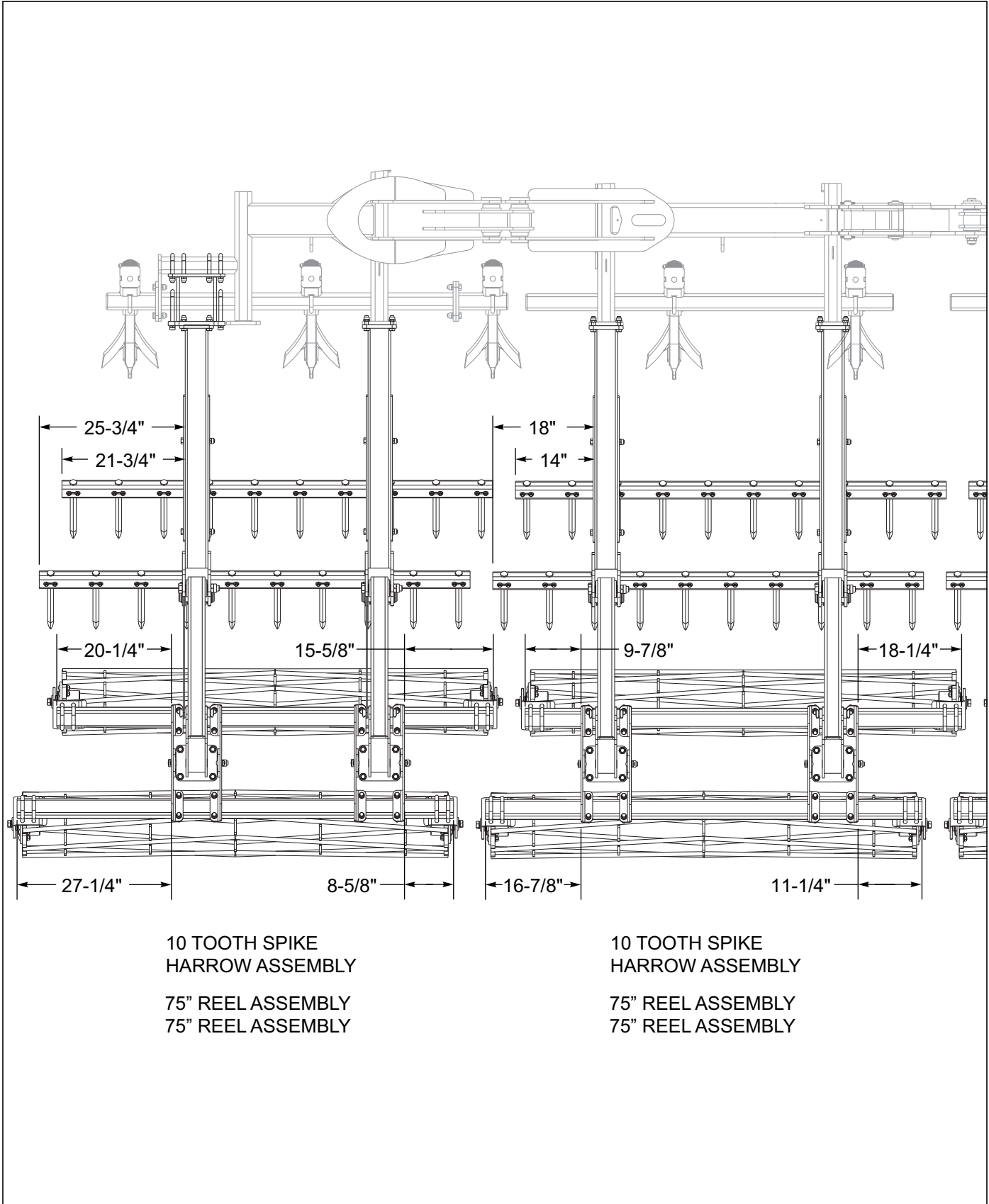

Figure 2-37: Spike & Double Placement 8550-38' LH

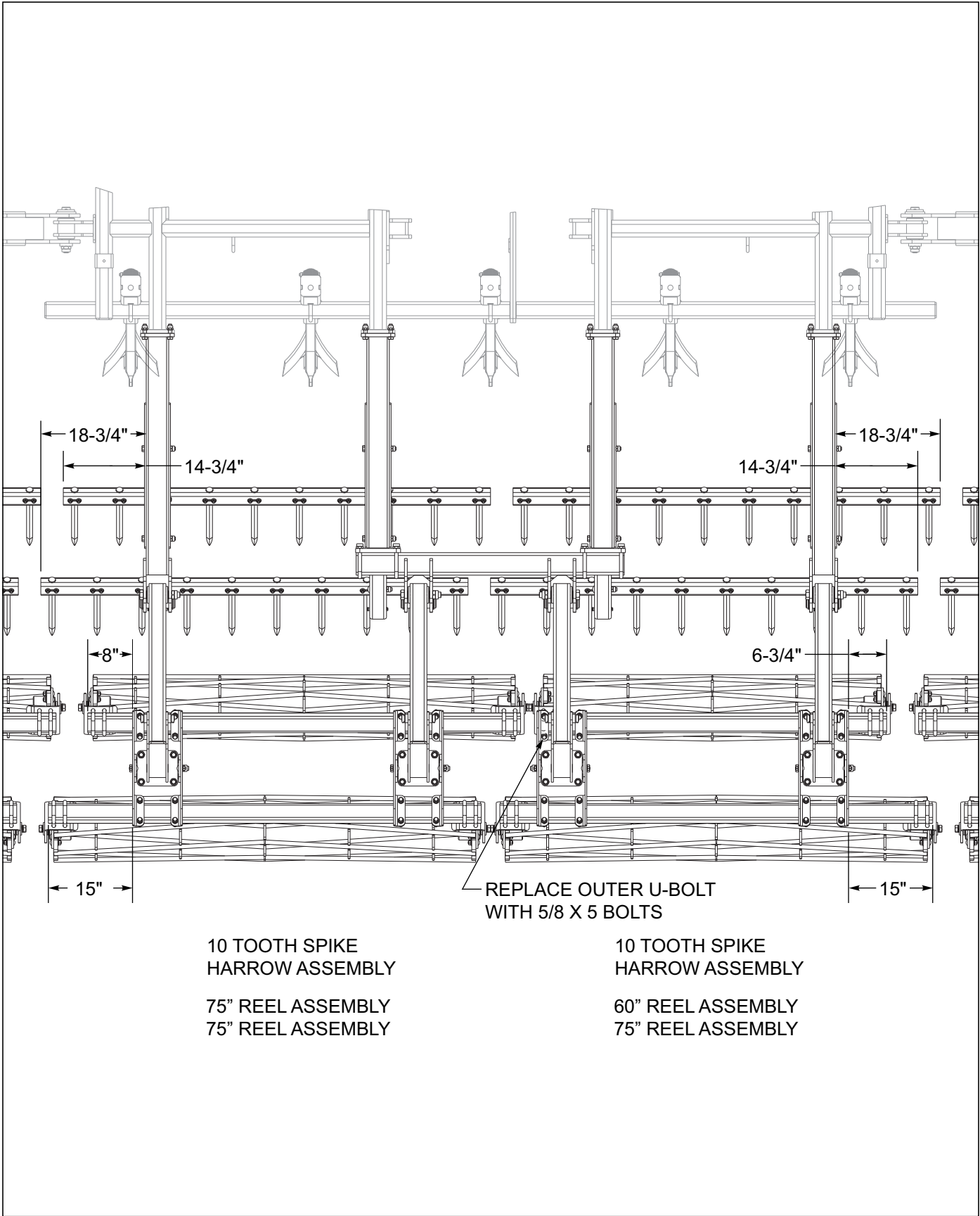

Figure 2-38: Spike & Double Placement 8550-38' MIDDLE

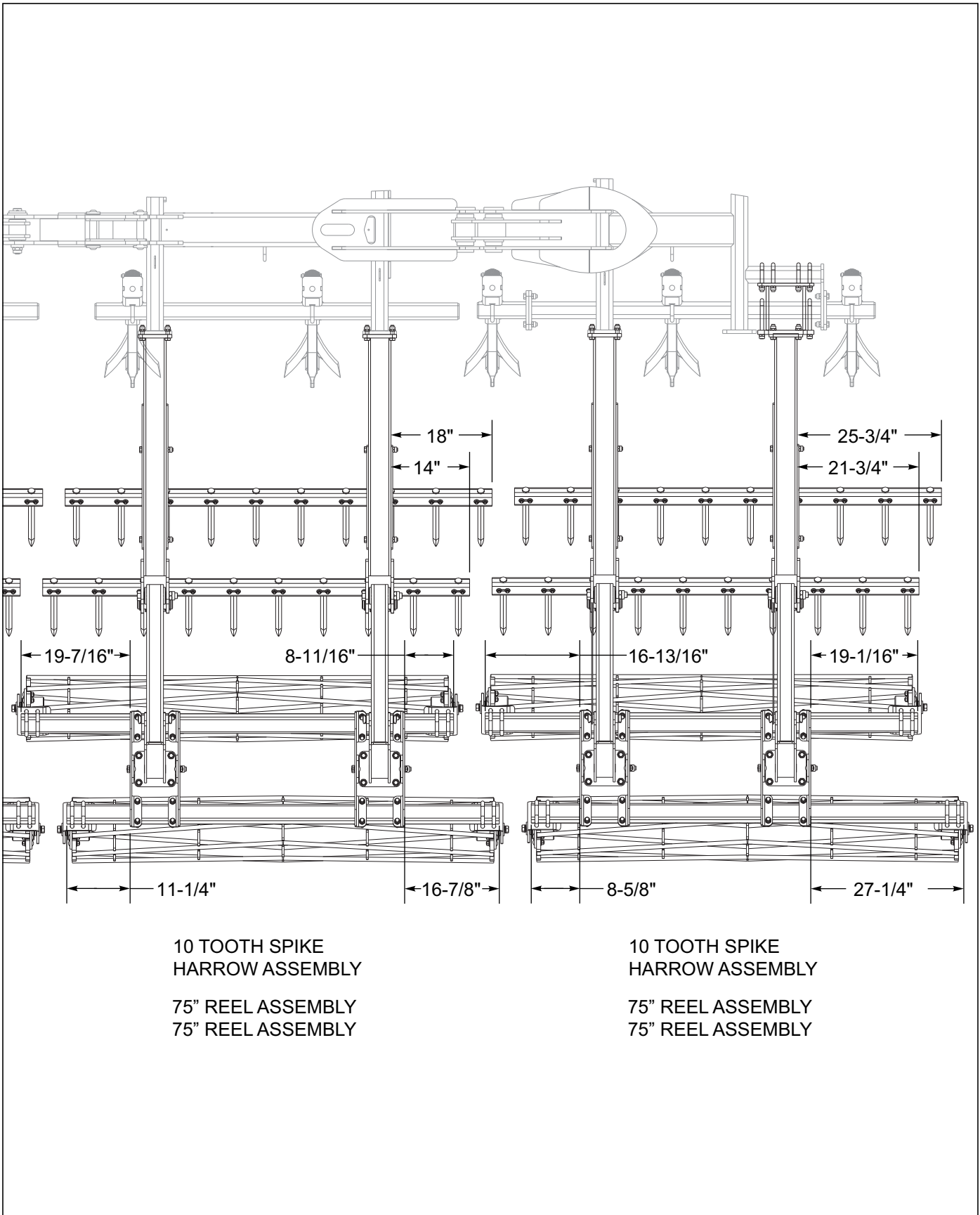

Figure 2-39: Spike & Double Placement 8550-38' RH

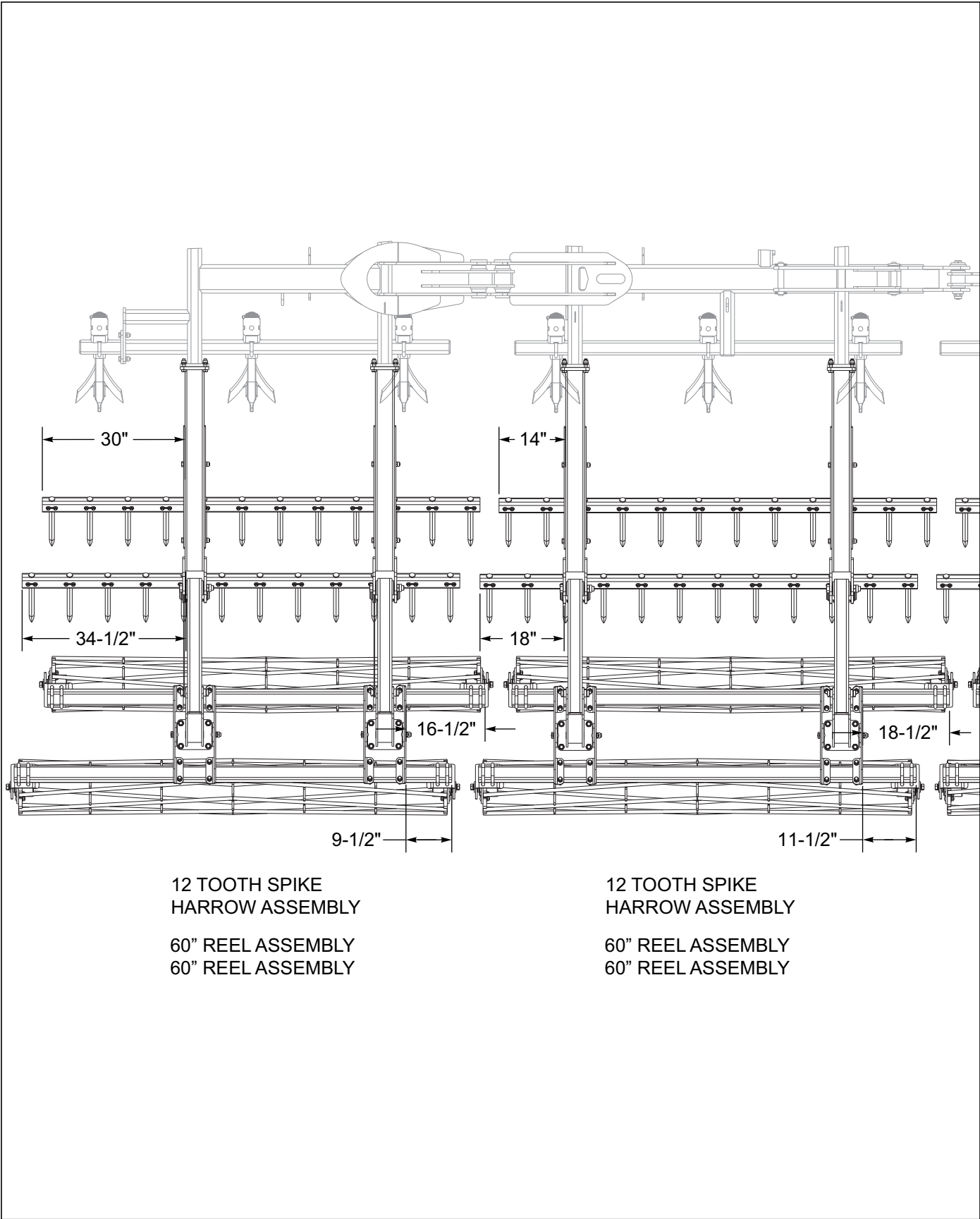

Figure 2-40: Spike & Double Placement 8550-43' LH

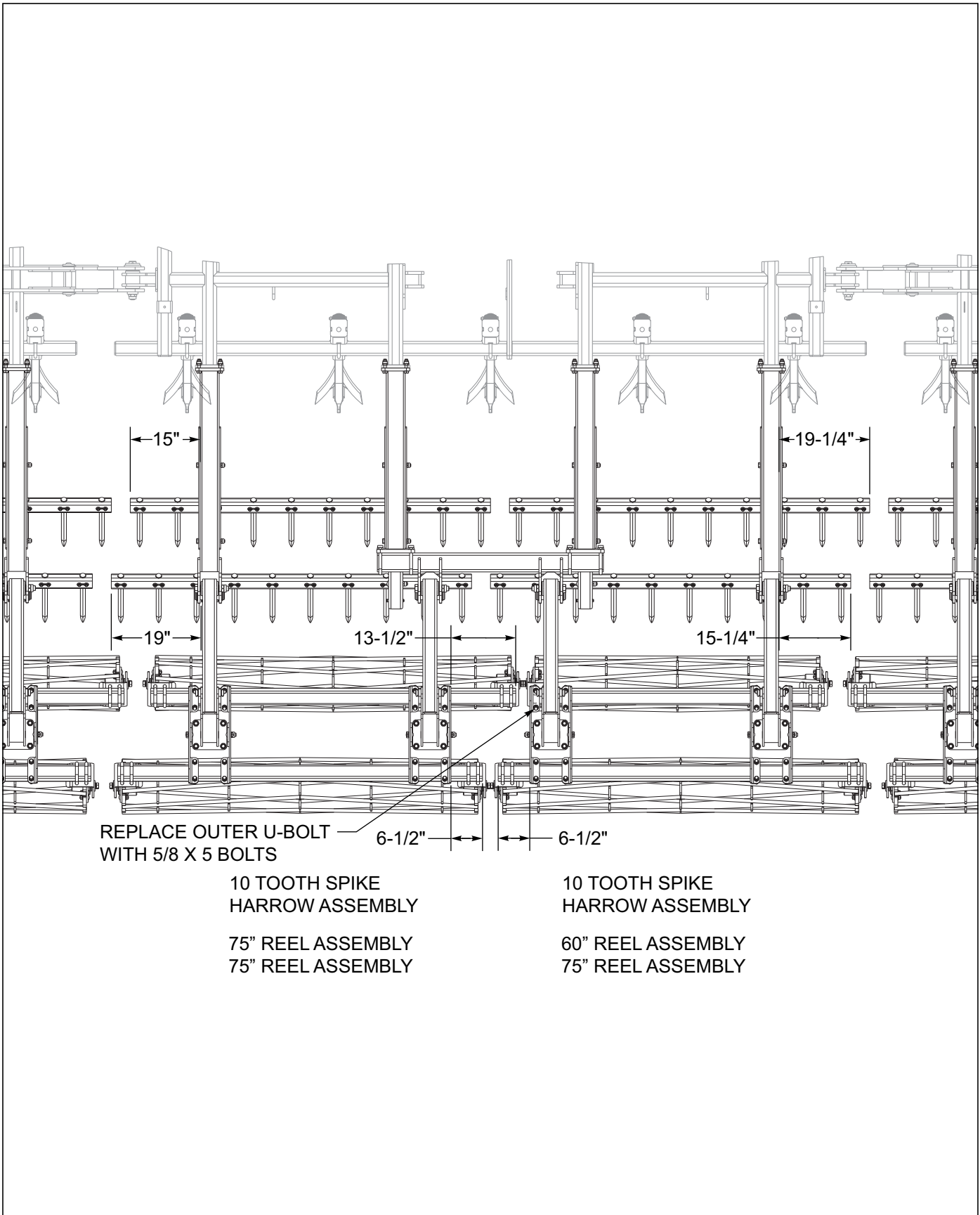

Figure 2-41: Spike & Double Placement 8550-43' MIDDLE

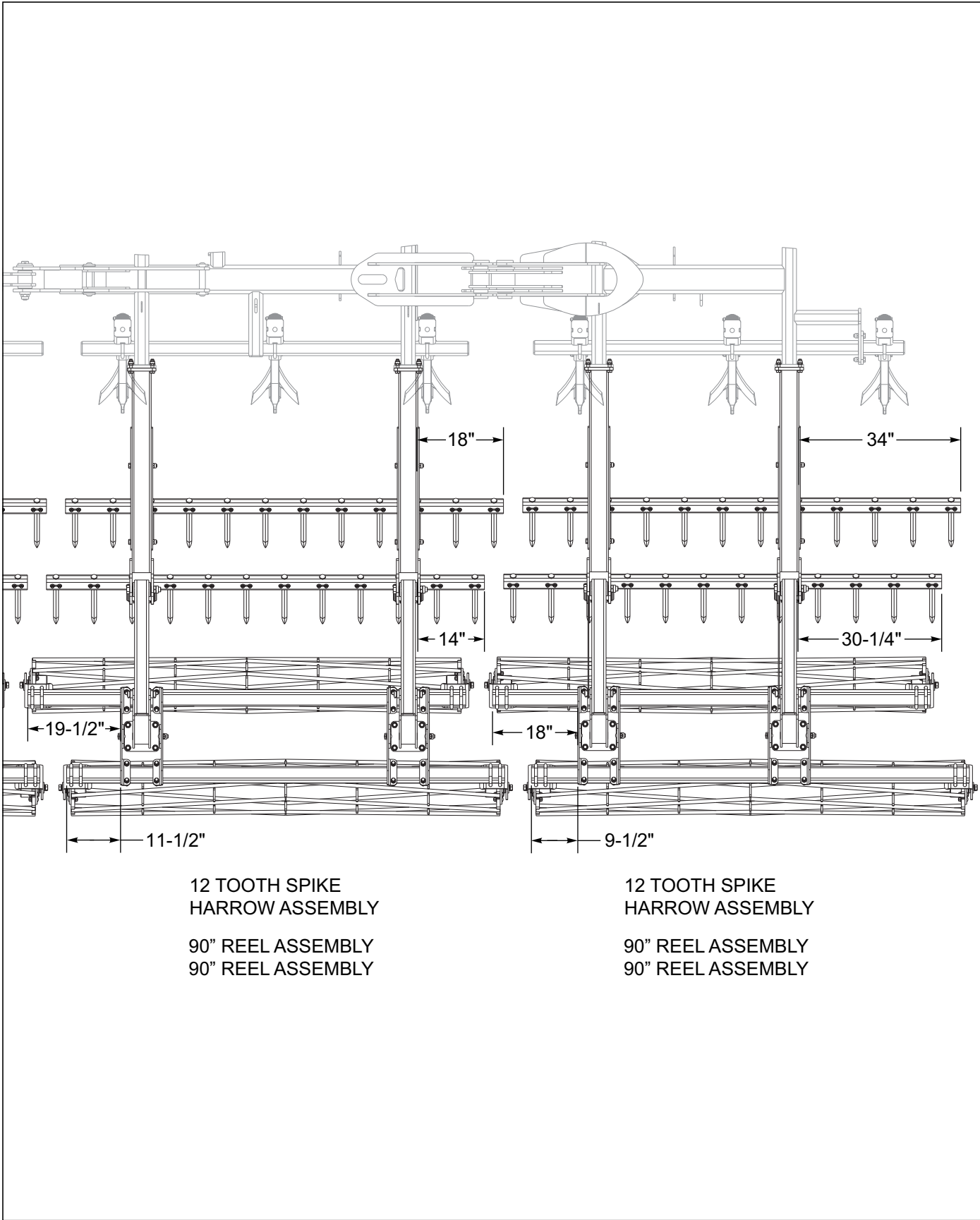

Figure 2-42: Spike & Double Reel Placement 8550-43' RH

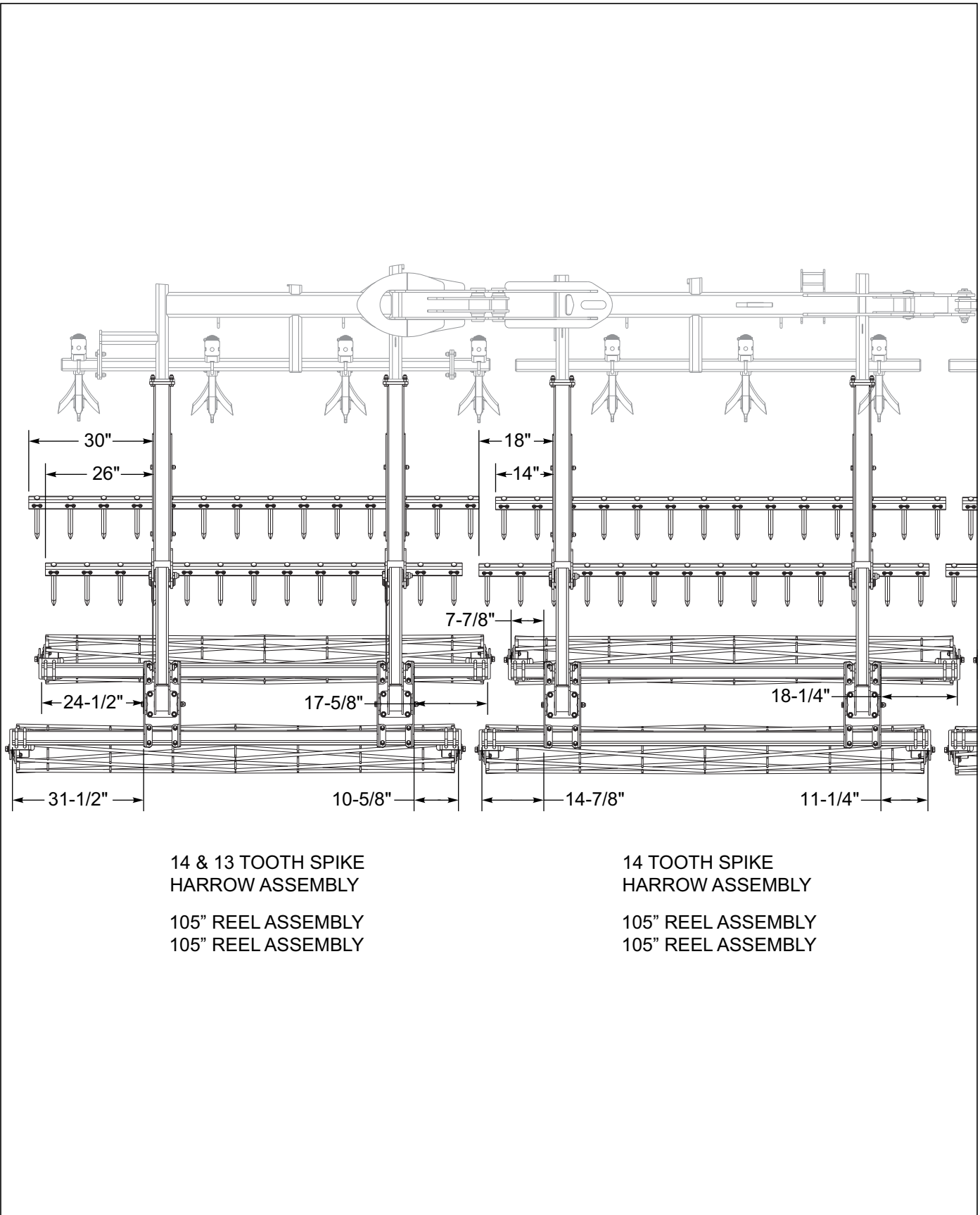

Figure 2-43: Spike & Double Placement 8550-48' LH

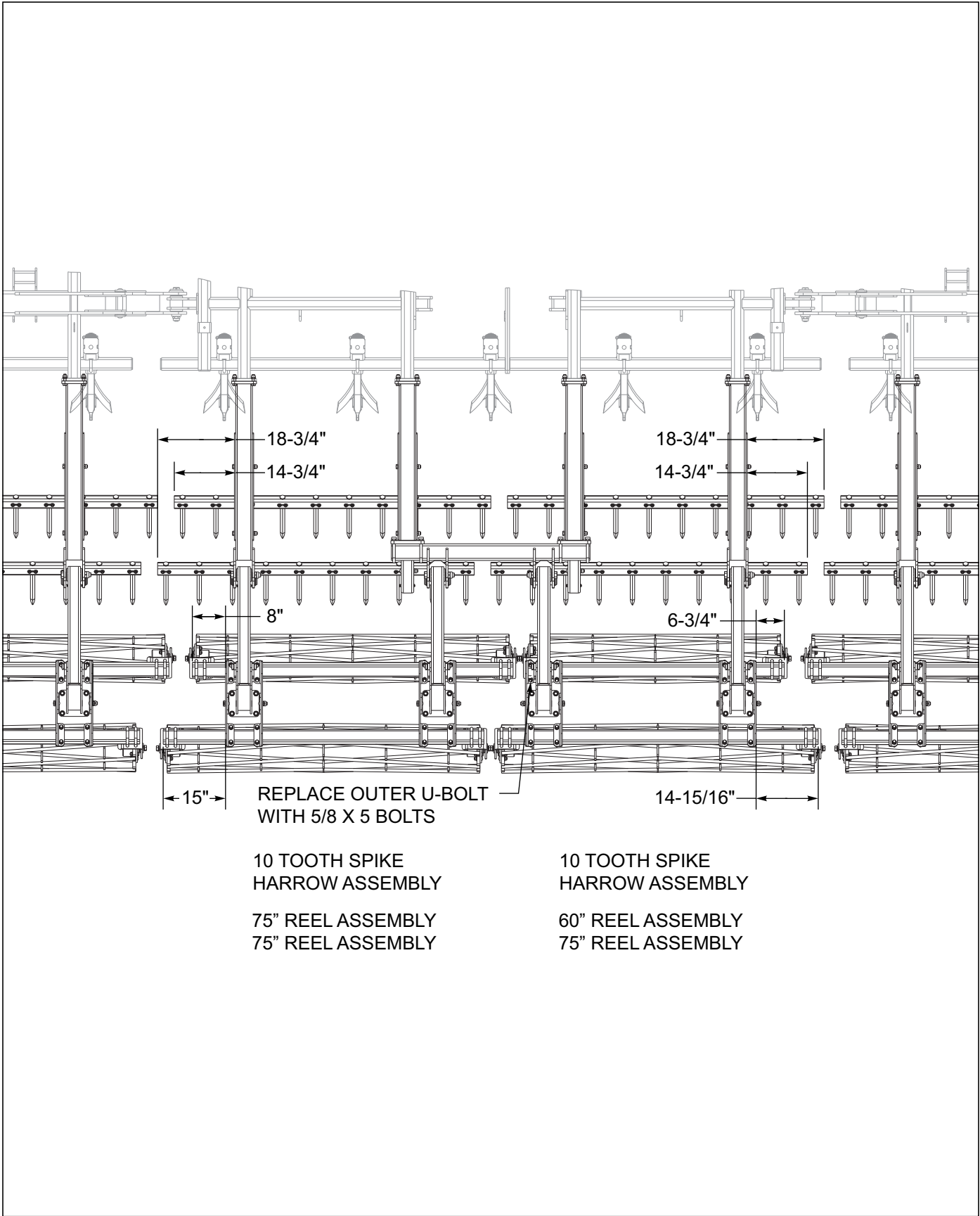

Figure 2-44: Spike & Double Placement 8550-48' MIDDLE

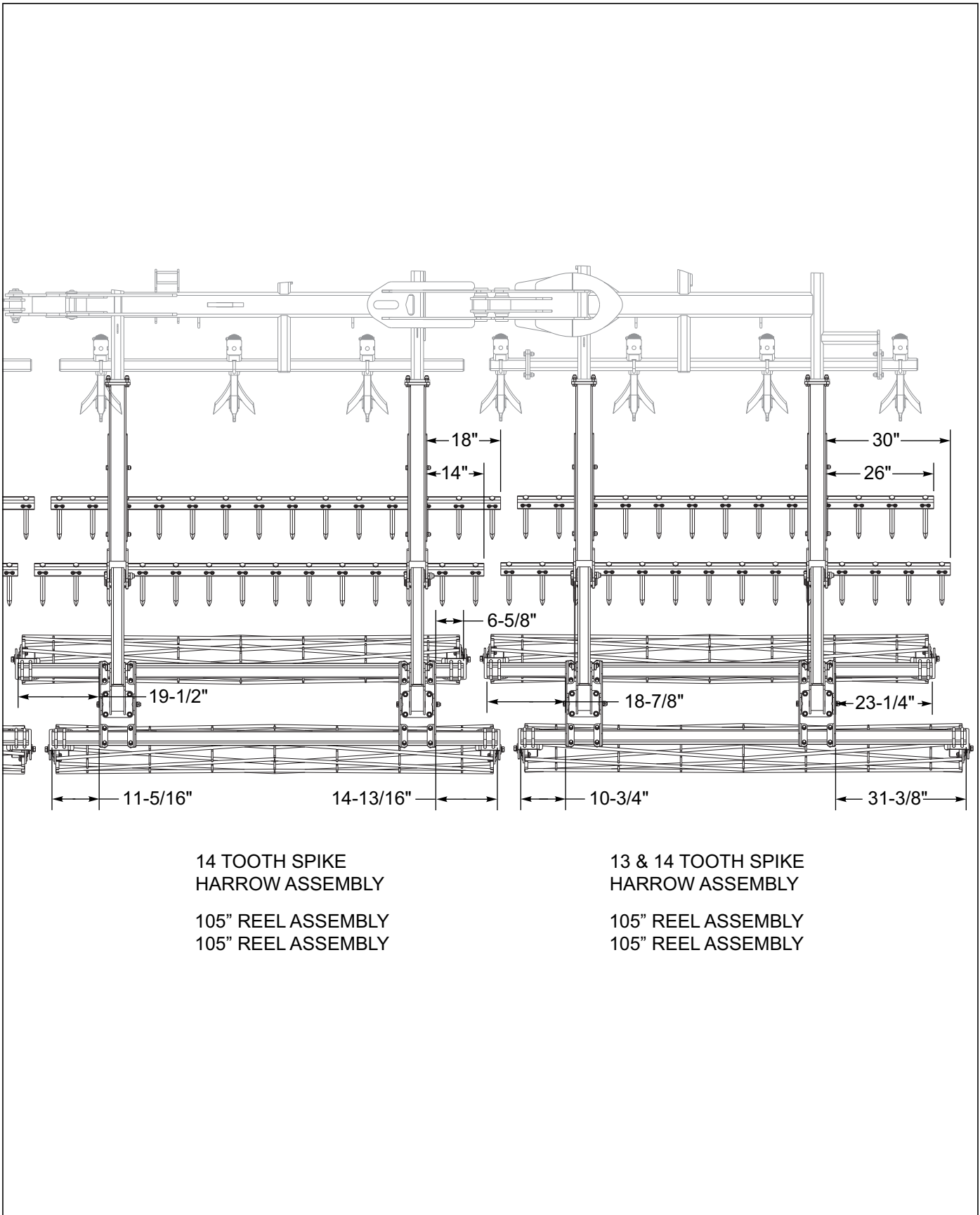
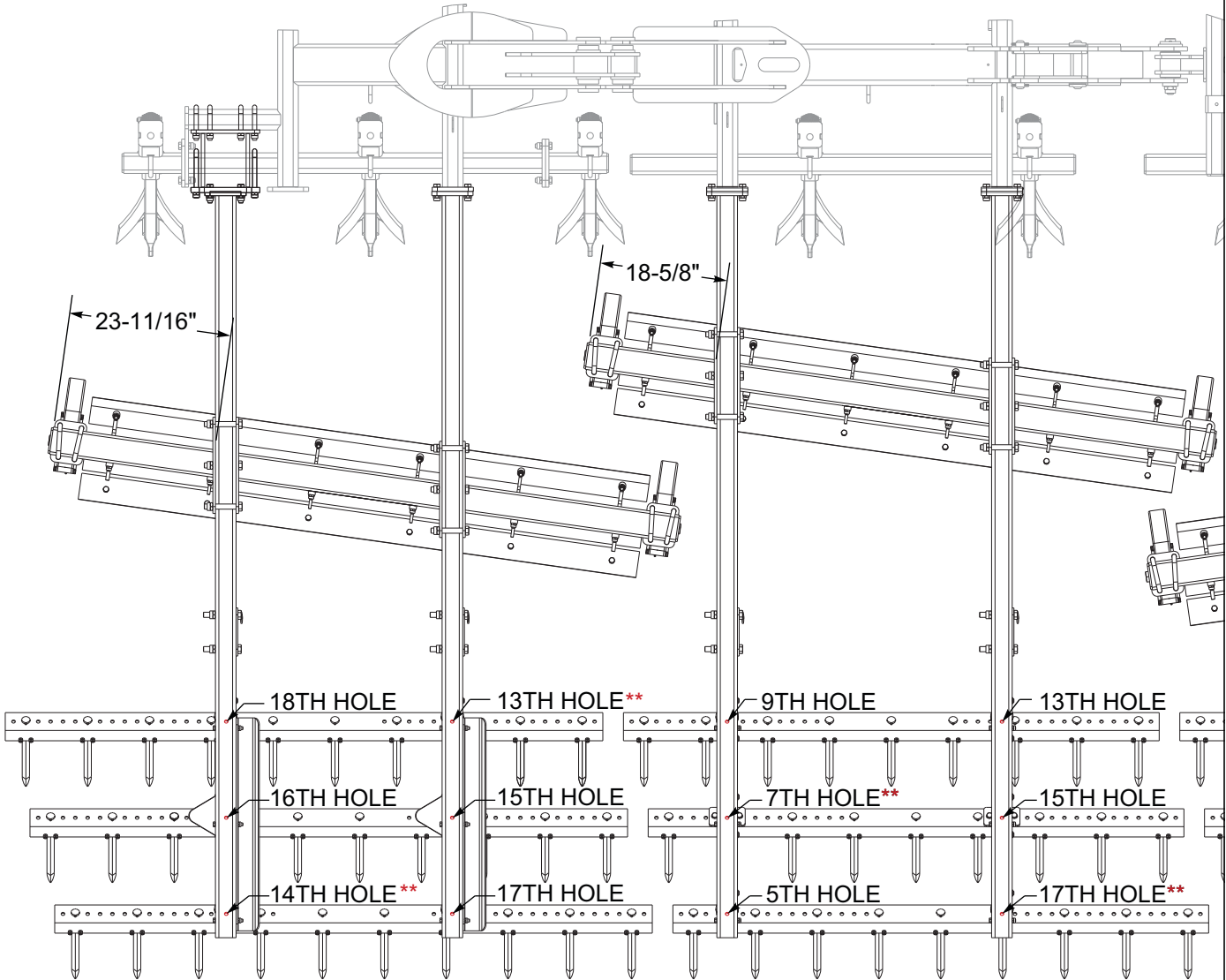

Figure 2-45: Spike & Double Reel Placement 8550-48' RH

Chopper & 3 Row Spike Placement

** DENOTES USE OF BAR CLAMP W/TABS (P/N 186200)

NOTE: FOR PROPER SPIKE HARROW PLACEMENT. BE SURE TO COUNT BOTH ROUND AND SQUARE SPIKE HOLES.



82" REEL/GANGBAR ASSEMBLY
 10 TOOTH SPIKE HARROW ASSEMBLY

82" REEL/GANGBAR ASSEMBLY
 9 TOOTH SPIKE HARROW ASSEMBLY

Figure 2-46: Chopper & 3 Row Spike Placement 8550-38' LH

STANDARD SPECIFICATIONS

** DENOTES USE OF
BAR CLAMP W/TABS
(P/N 186200)

NOTE: FOR PROPER SPIKE HARROW PLACEMENT.
BE SURE TO COUNT BOTH ROUND AND SQUARE
SPIKE HOLES.

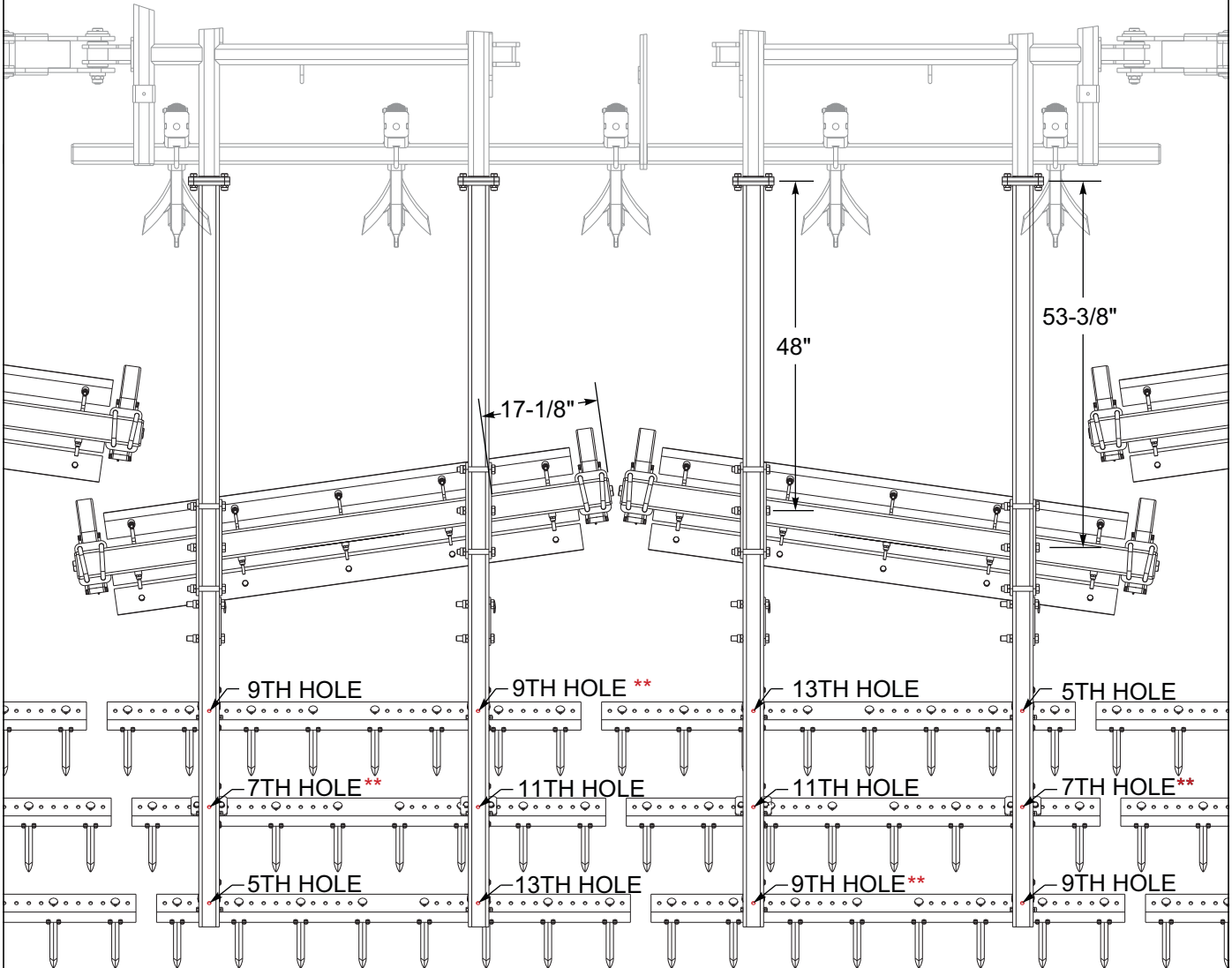

68-1/2" REEL/GANGBAR
ASSEMBLY
8 TOOTH SPIKE
HARROW ASSEMBLY

68-1/2" REEL/GANGBAR
ASSEMBLY
8 TOOTH SPIKE
HARROW ASSEMBLY

Figure 2-47: Chopper & 3 Row Spike Placement 8550-38' MIDDLE

** DENOTES USE OF BAR CLAMP W/TABS (P/N 186200)

NOTE: FOR PROPER SPIKE HARROW PLACEMENT, BE SURE TO COUNT BOTH ROUND AND SQUARE SPIKE HOLES.

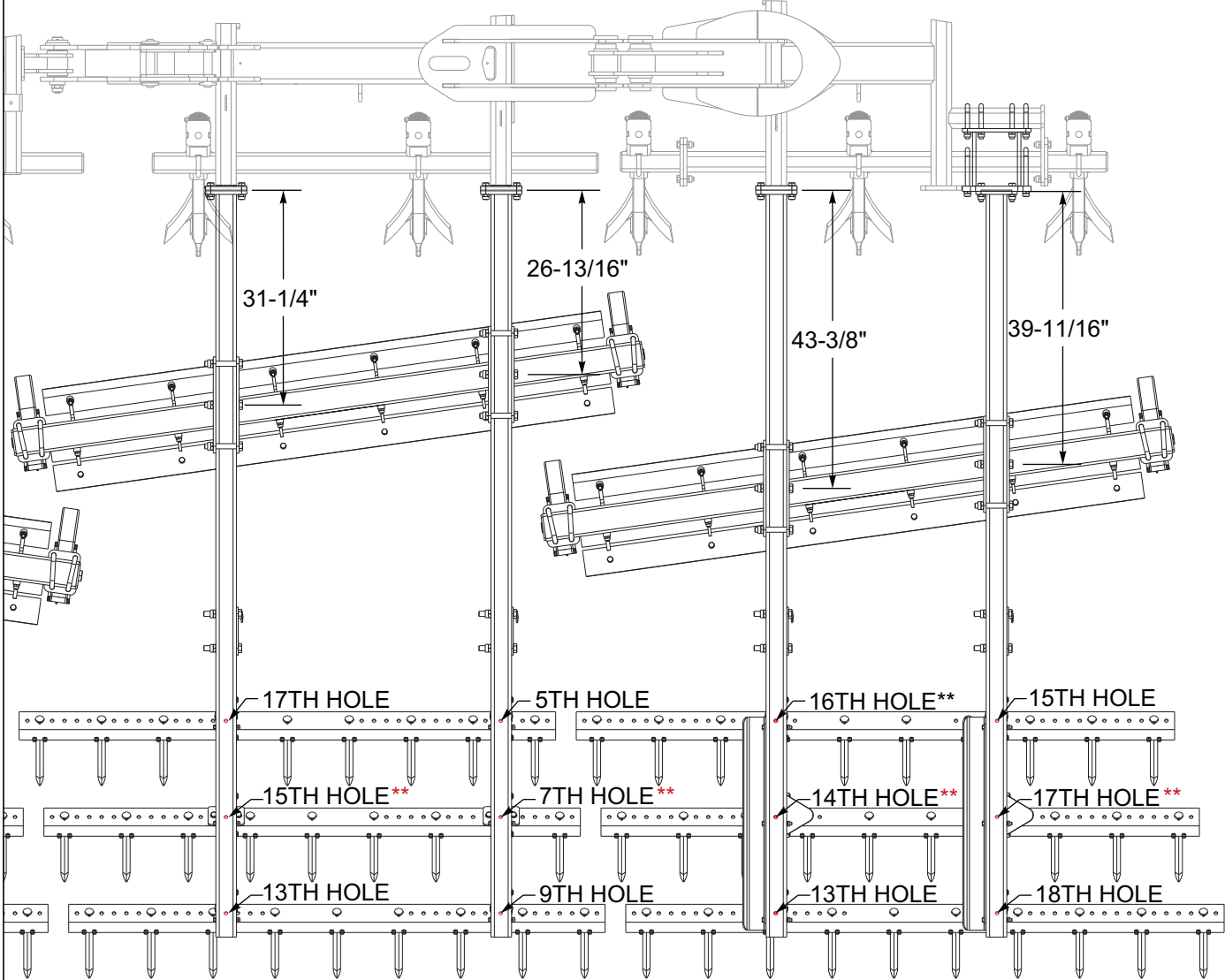

82" REEL/GANGBAR ASSEMBLY
9 TOOTH SPIKE HARROW ASSEMBLY

82" REEL/GANGBAR ASSEMBLY
10 TOOTH SPIKE HARROW ASSEMBLY

Figure 2-48: Chopper & 3 Row Spike Placement 8550-38' RH

STANDARD SPECIFICATIONS

** DENOTES USE OF
BAR CLAMP W/TABS
(P/N 186200)

NOTE: FOR PROPER SPIKE HARROW PLACEMENT.
BE SURE TO COUNT BOTH ROUND AND SQUARE
SPIKE HOLES.

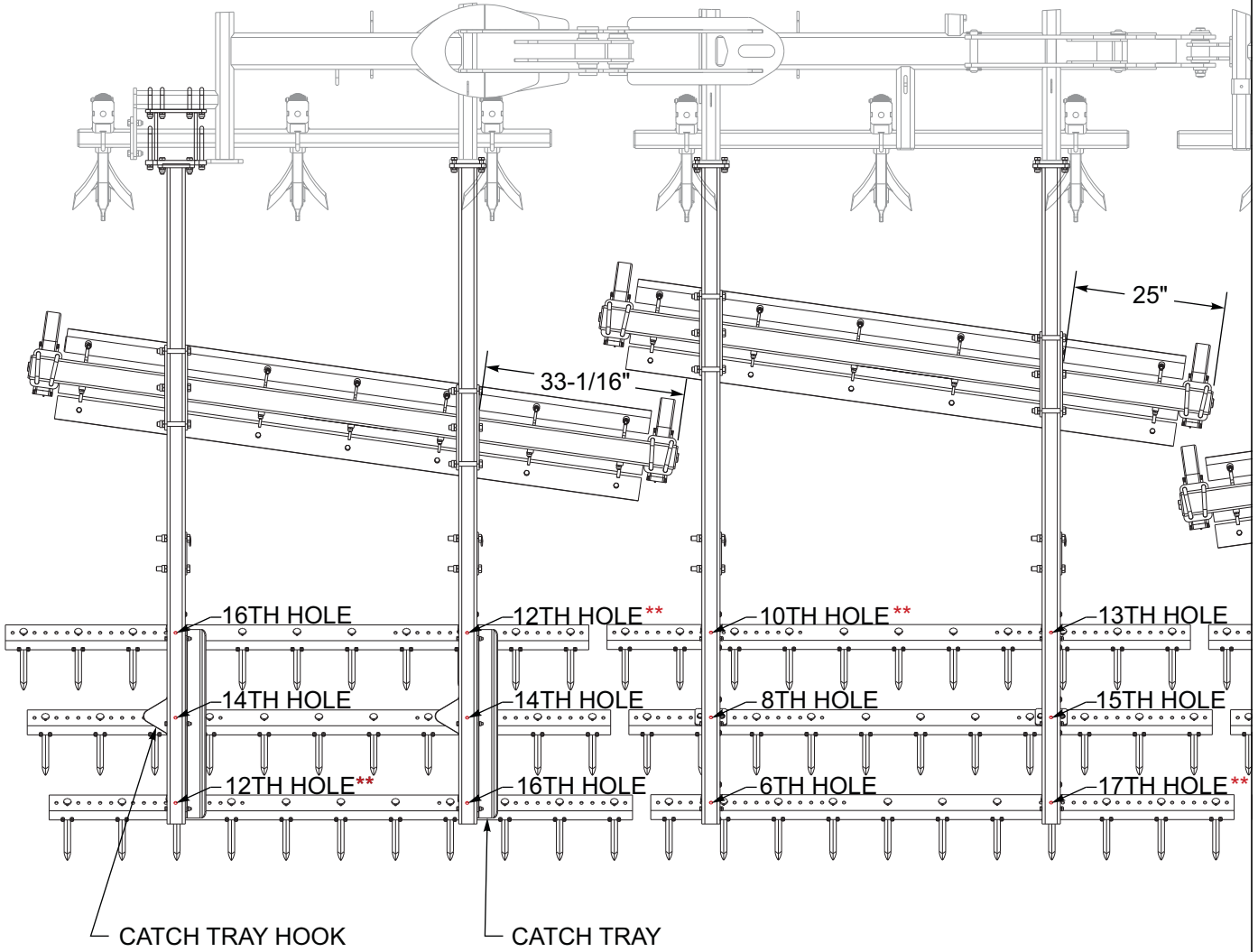

97" REEL/GANGBAR
ASSEMBLY
11 TOOTH SPIKE
HARROW ASSEMBLY

91" REEL/GANGBAR
ASSEMBLY
11 TOOTH SPIKE
HARROW ASSEMBLY

Figure 2-49: Chopper & 3 Row Spike Placement 8550-43' LH

** DENOTES USE OF
BAR CLAMP W/TABS
(P/N 186200)

NOTE: FOR PROPER SPIKE HARROW PLACEMENT.
BE SURE TO COUNT BOTH ROUND AND SQUARE
SPIKE HOLES.

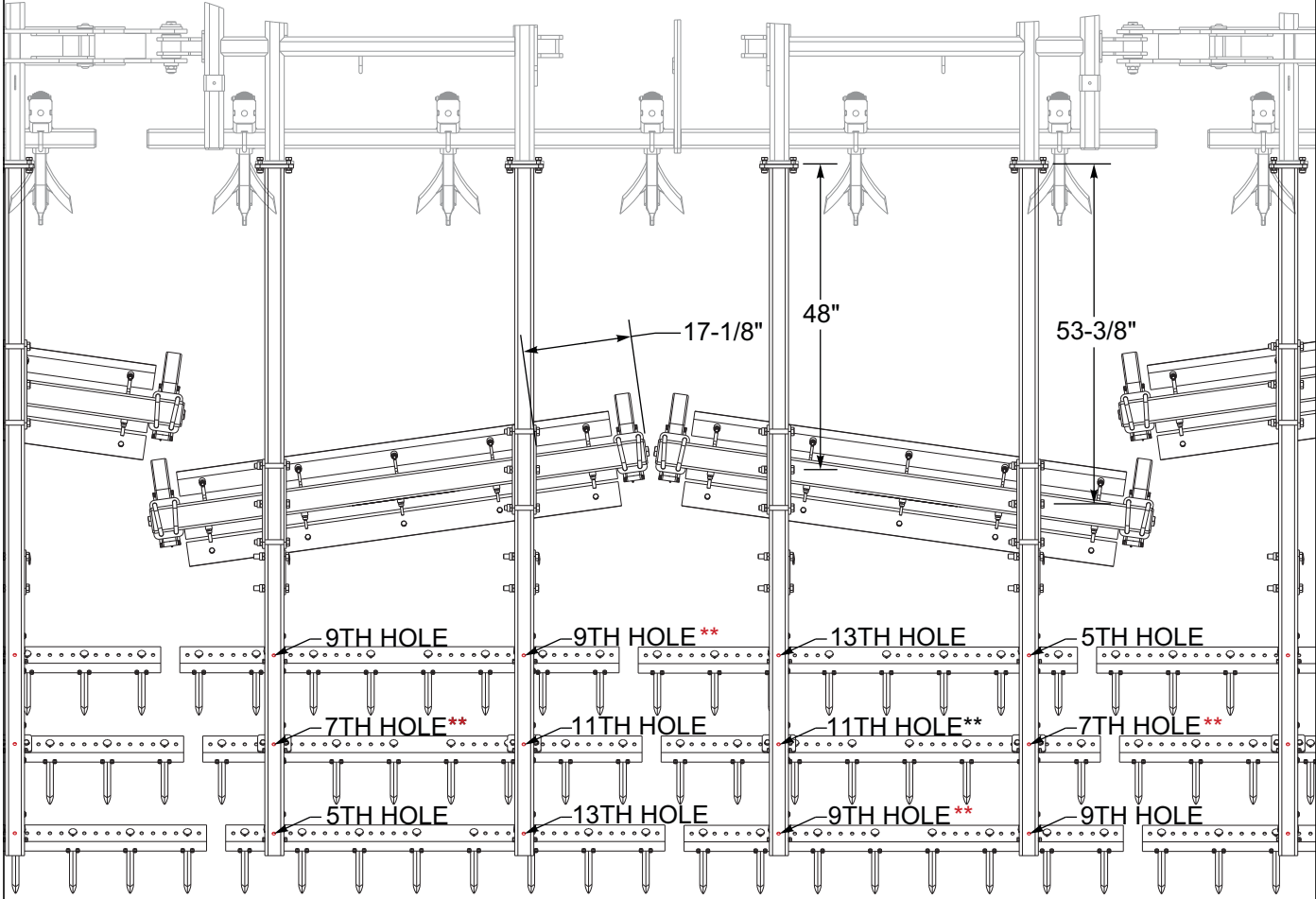

68-1/2" REEL/GANGBAR
ASSEMBLY
8 TOOTH SPIKE
HARROW ASSEMBLY

68-1/2" REEL/GANGBAR
ASSEMBLY
8 TOOTH SPIKE
HARROW ASSEMBLY

Figure 2-50: Chopper & 3 Row Spike Placement 8550-43' MIDDLE

STANDARD SPECIFICATIONS

** DENOTES USE OF
BAR CLAMP W/TABS
(P/N 186200)

NOTE: FOR PROPER SPIKE HARROW PLACEMENT,
BE SURE TO COUNT BOTH ROUND AND SQUARE
SPIKE HOLES.

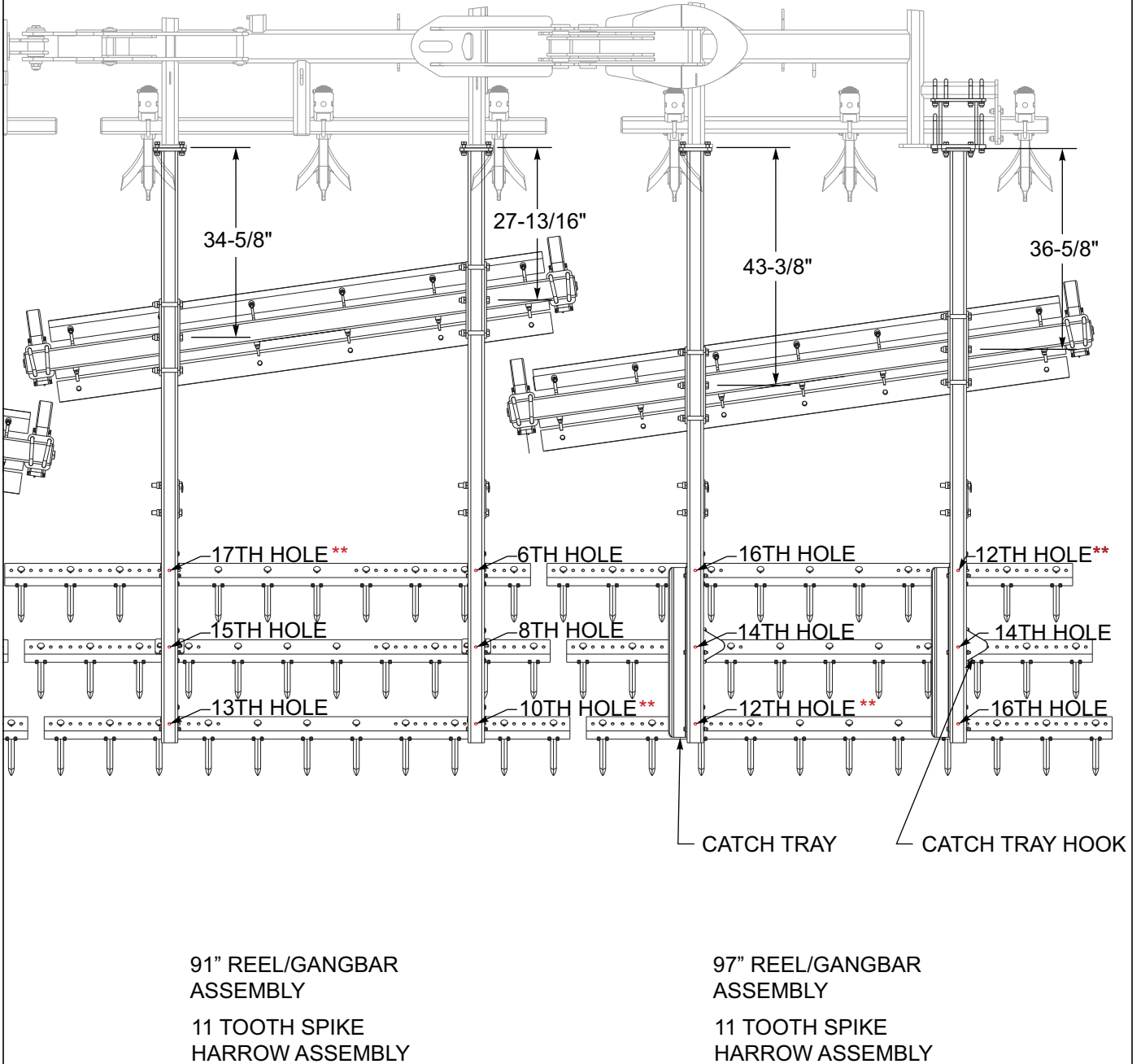

Figure 2-51: Chopper & 3 Row Spike Placement 8550-43' RH

** DENOTES USE OF BAR CLAMP W/TABS (P/N 186200)

NOTE: FOR PROPER SPIKE HARROW PLACEMENT, BE SURE TO COUNT BOTH ROUND AND SQUARE SPIKE HOLES.

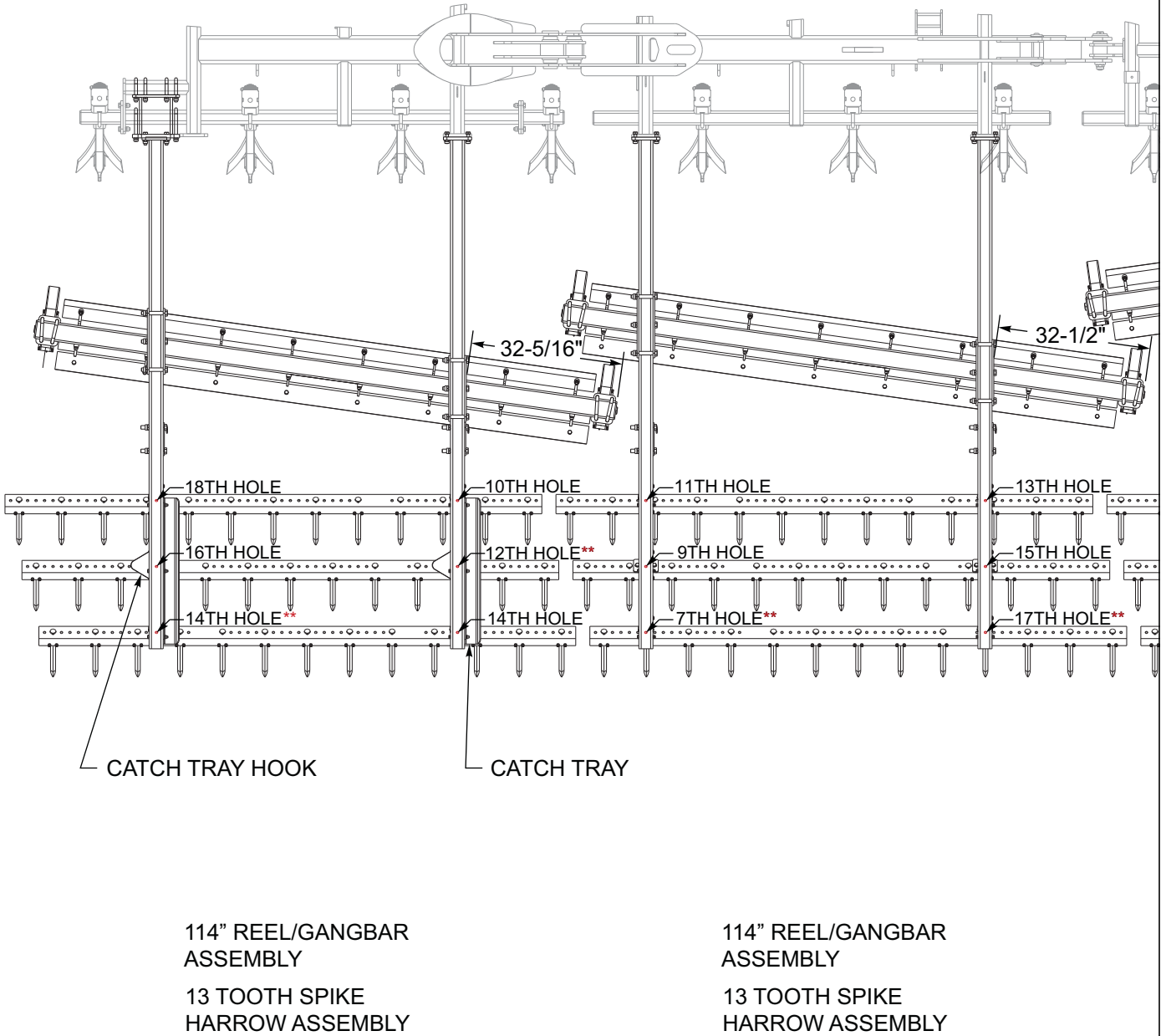
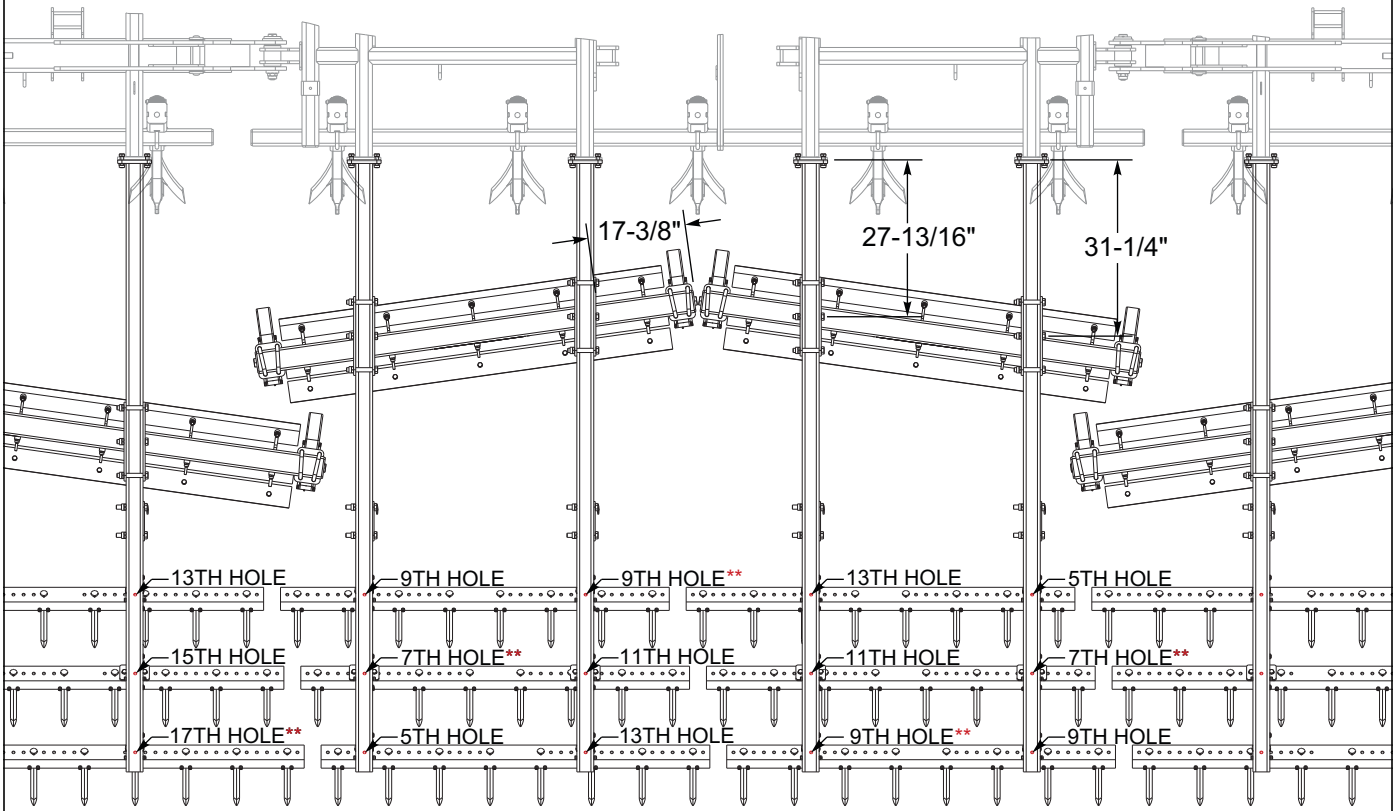

Figure 2-52: Chopper & 3 Row Spike Placement 8550-48' LH

STANDARD SPECIFICATIONS

** DENOTES USE OF
BAR CLAMP W/TABS
(P/N 186200)

NOTE: FOR PROPER SPIKE HARROW PLACEMENT.
BE SURE TO COUNT BOTH ROUND AND SQUARE
SPIKE HOLES.



68-1/2" REEL/GANGBAR
ASSEMBLY

8 TOOTH SPIKE
HARROW ASSEMBLY

68-1/2" REEL/GANGBAR
ASSEMBLY

8 TOOTH SPIKE
HARROW ASSEMBLY

Figure 2-53: Chopper & 3 Row Spike Placement 8550-48' MIDDLE

** DENOTES USE OF BAR CLAMP W/TABS (P/N 186200)

NOTE: FOR PROPER SPIKE HARROW PLACEMENT, BE SURE TO COUNT BOTH ROUND AND SQUARE SPIKE HOLES.

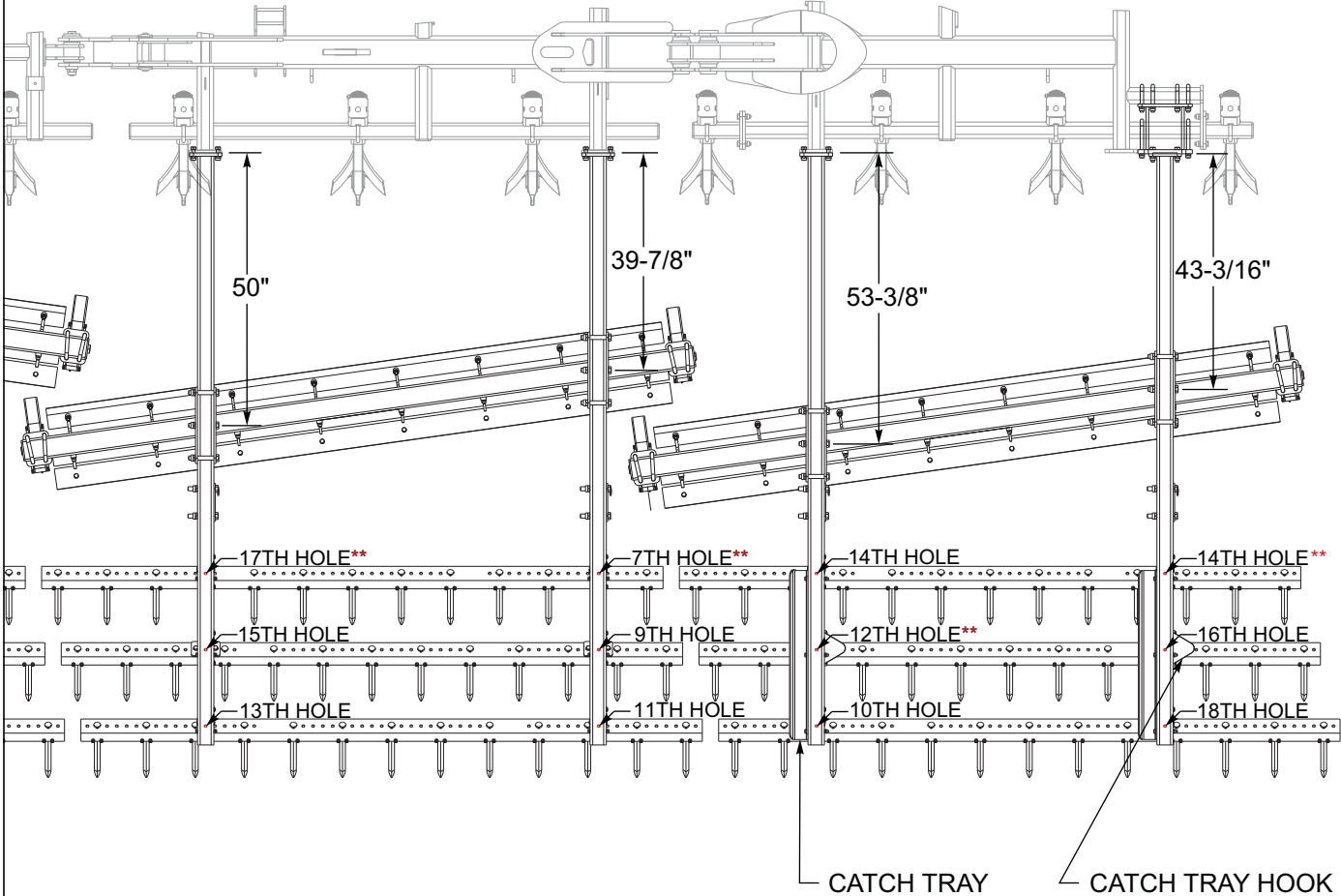

114" REEL/GANGBAR ASSEMBLY
13 TOOTH SPIKE HARROW ASSEMBLY

114" REEL/GANGBAR ASSEMBLY
13 TOOTH SPIKE HARROW ASSEMBLY

Figure 2-54: Chopper & 3 Row Spike Placement 8550-48' RH

Chopper/Spike/Reel Placement

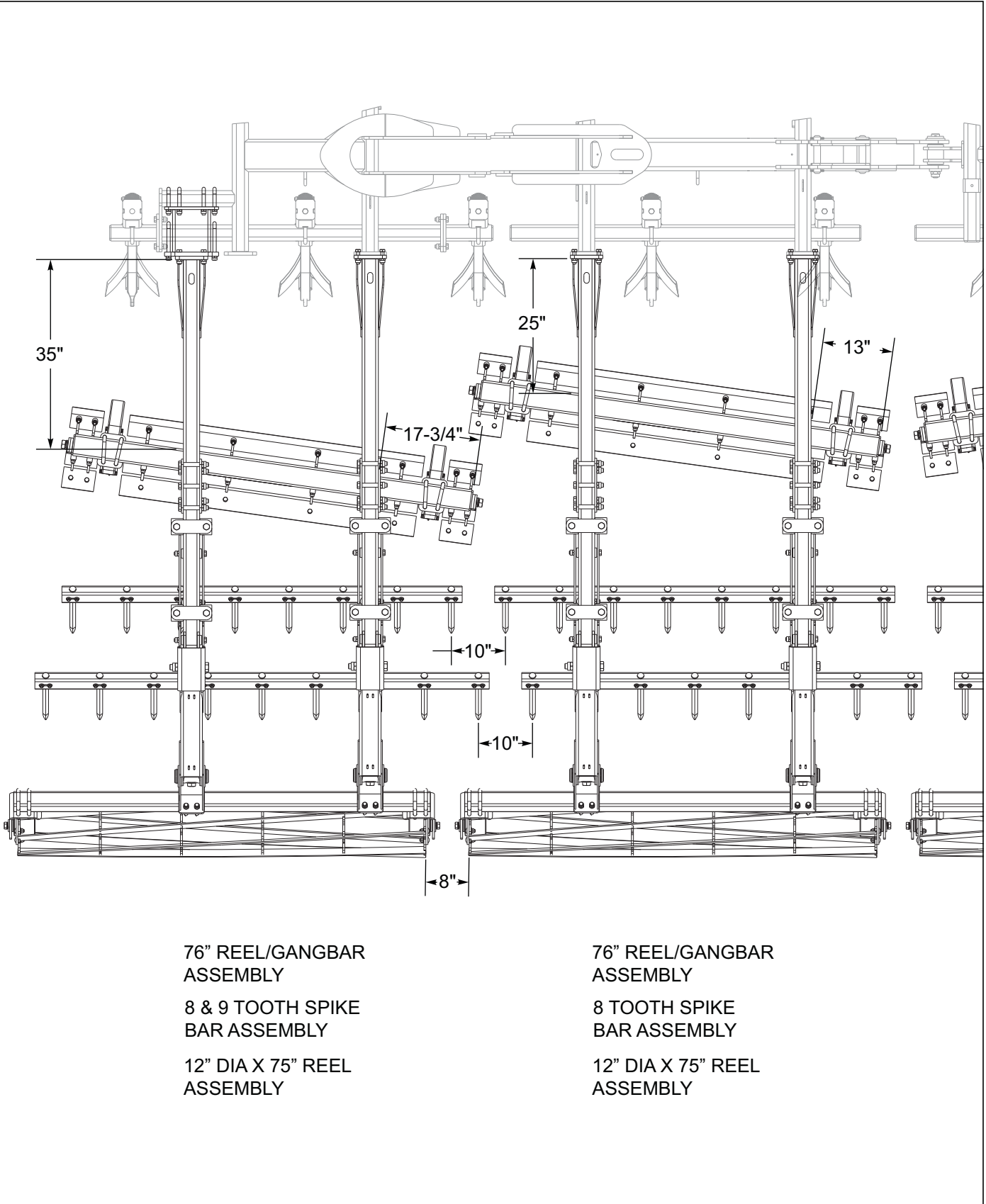

Figure 2-55: Chopper/Spike/Reel Placement 8550-38' LH

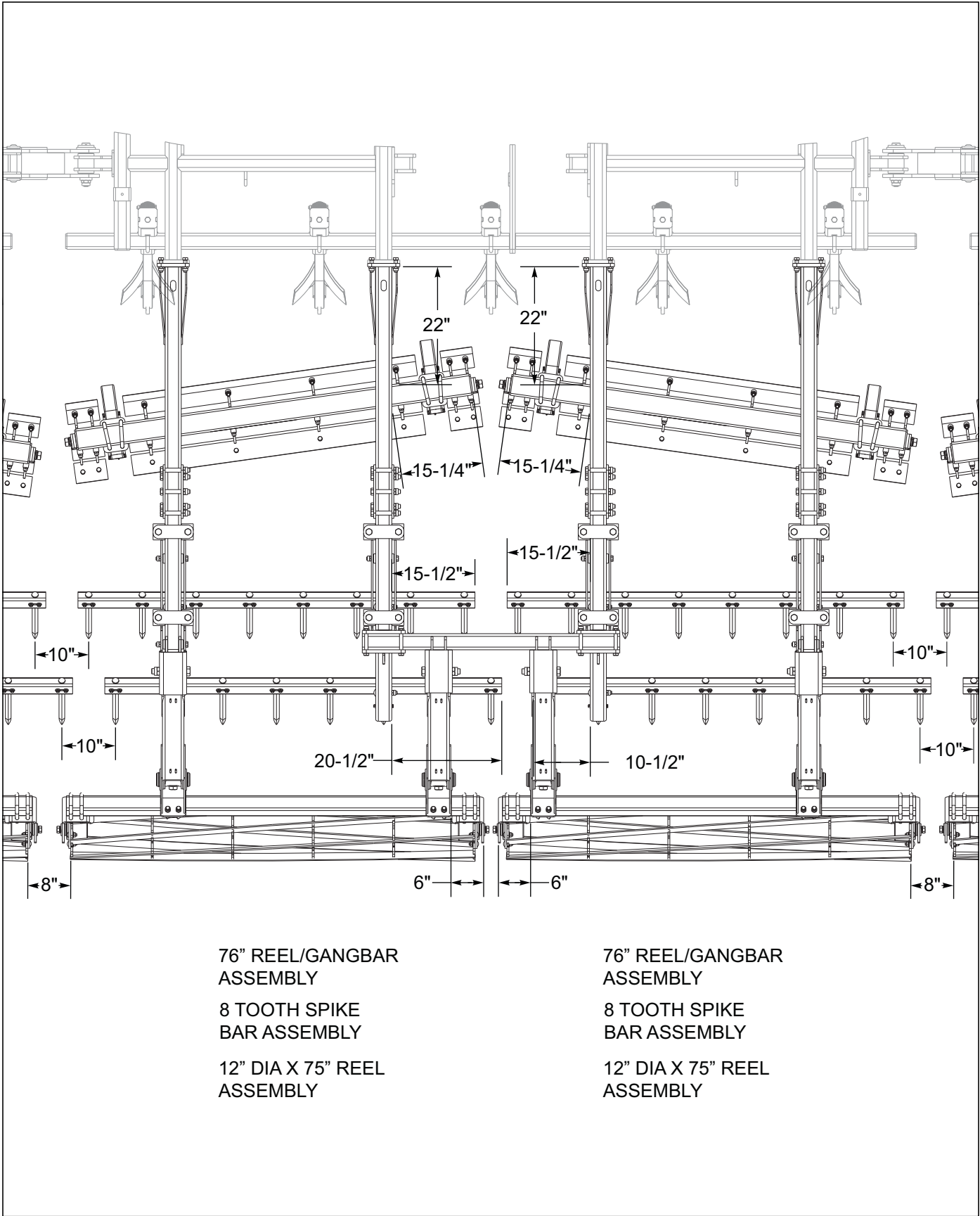

Figure 2-56: Chopper/Spike/Reel Placement 8550-38' MIDDLE

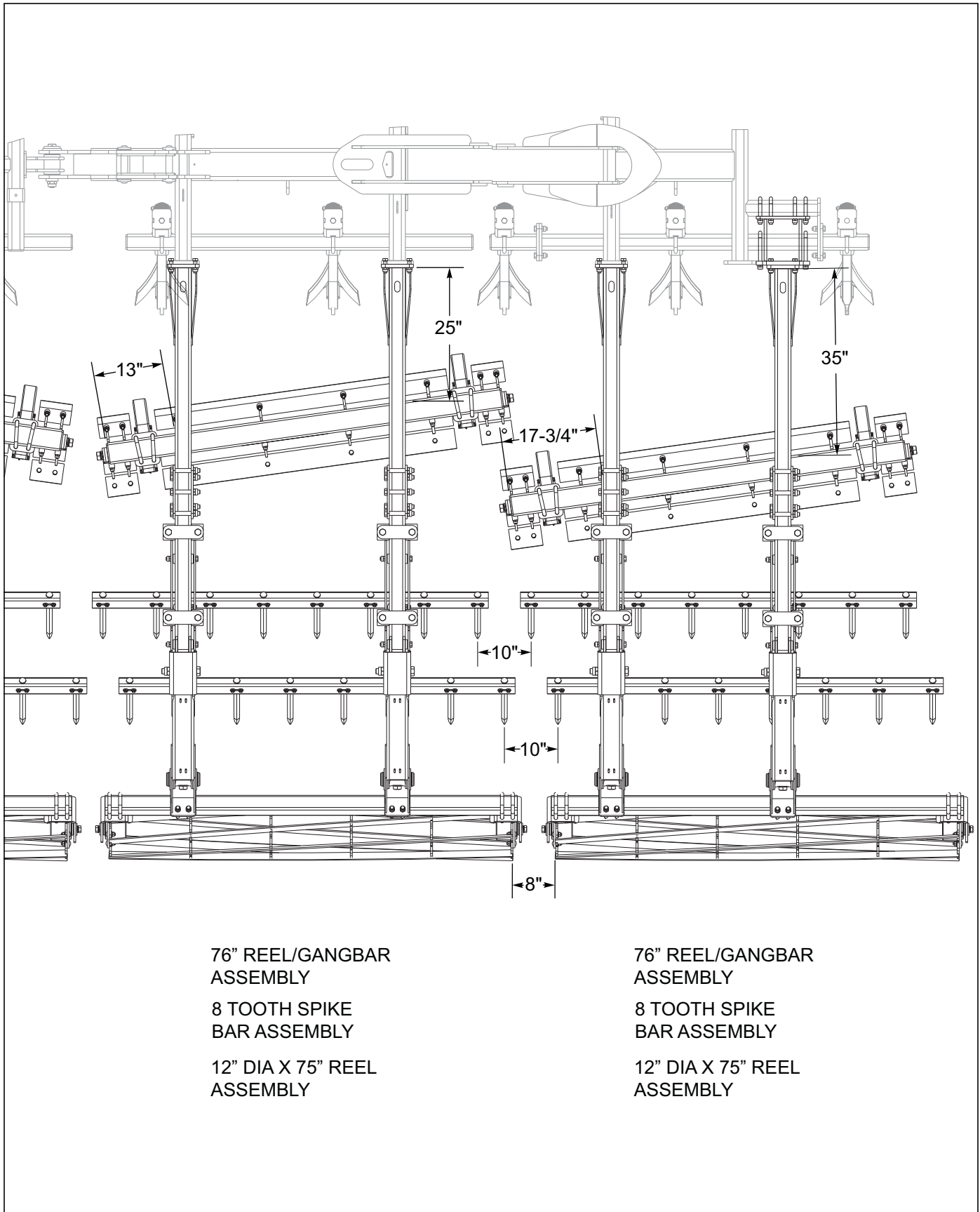

Figure 2-57: Chopper/Spike/Reel Placement 8550-38' RH

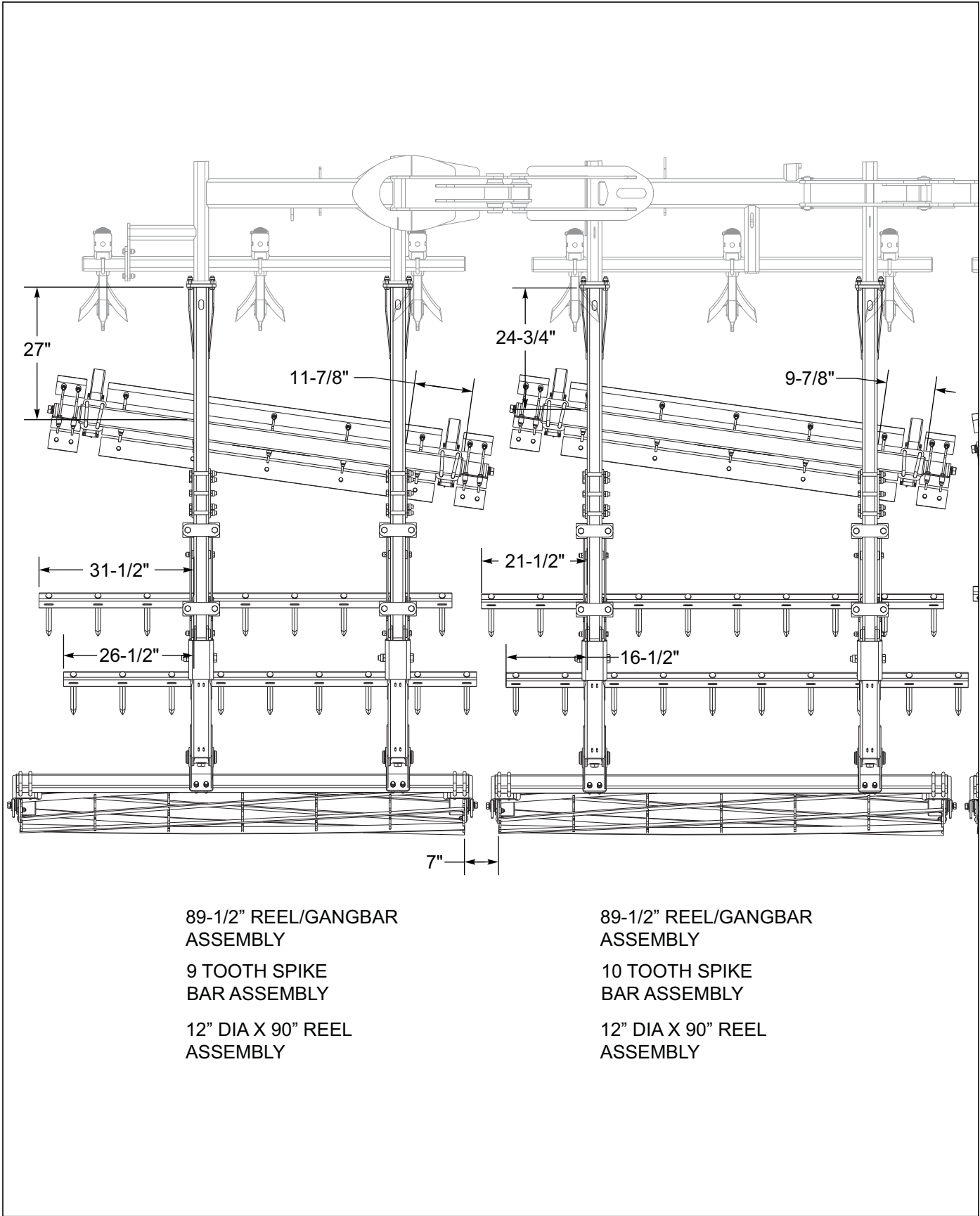

Figure 2-58: Chopper/Spike/Reel Placement 8550-43' LH

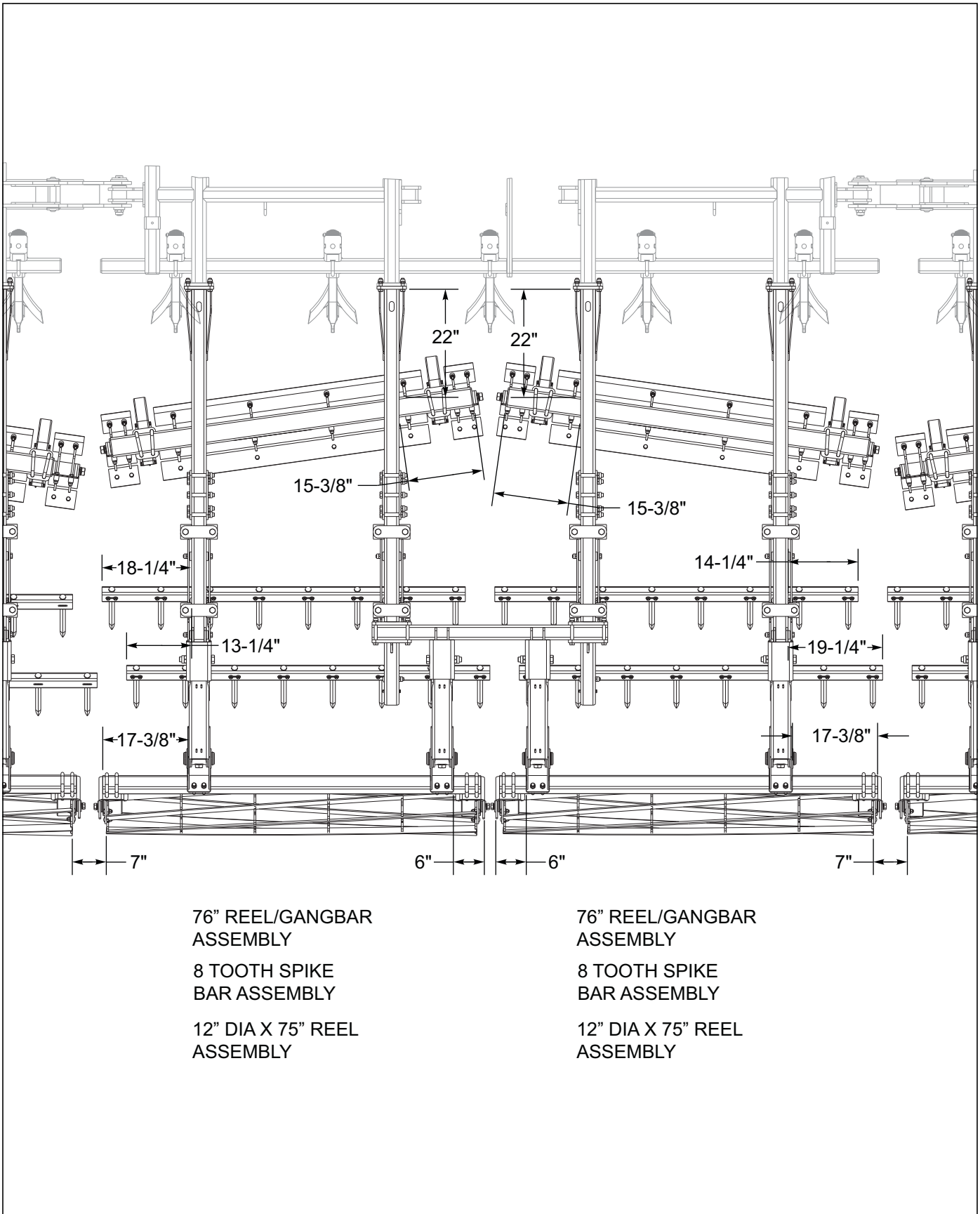
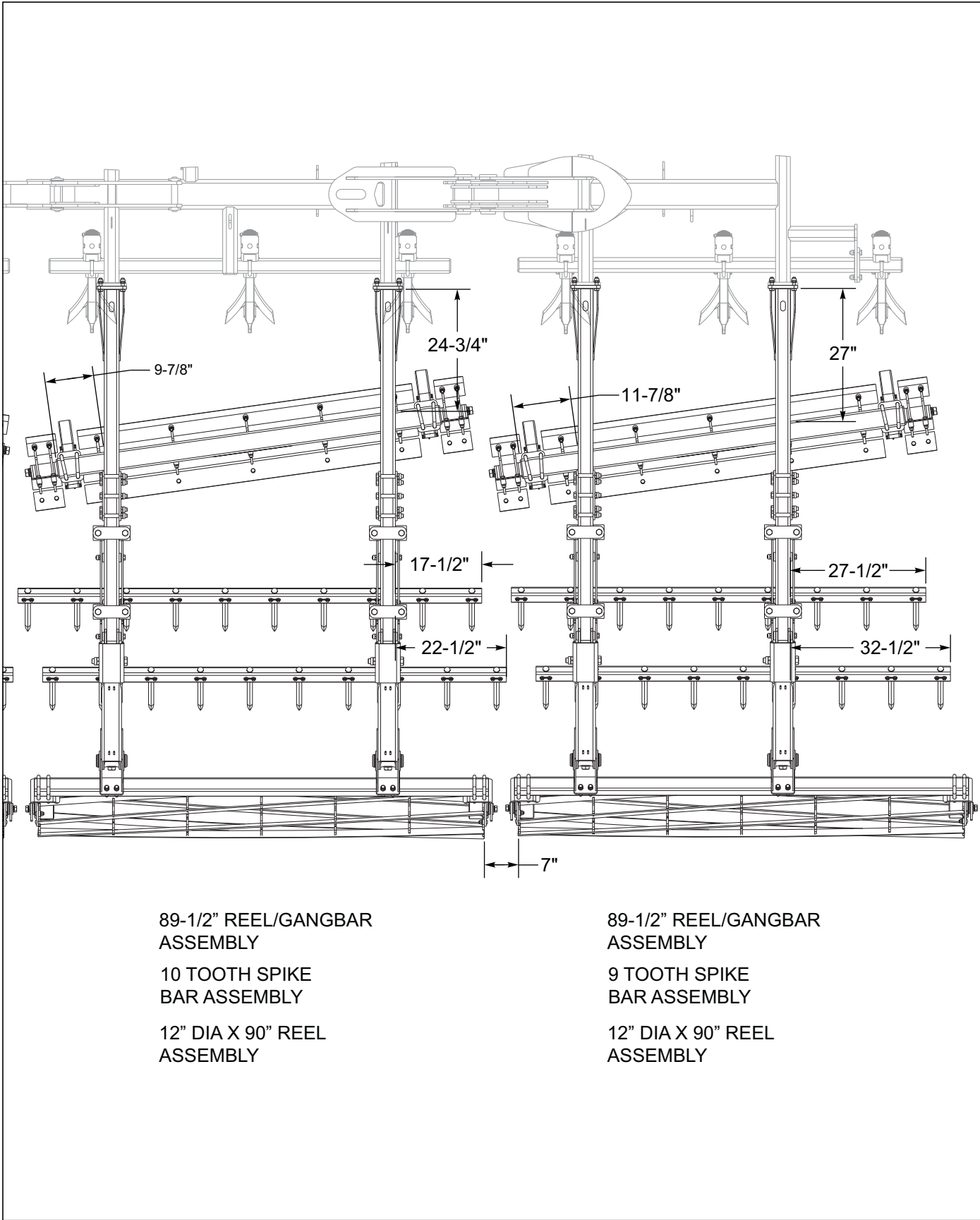

Figure 2-59: Chopper/Spike/Reel Placement 8550-43' MIDDLE



89-1/2" REEL/GANGBAR ASSEMBLY
10 TOOTH SPIKE BAR ASSEMBLY
12" DIA X 90" REEL ASSEMBLY

89-1/2" REEL/GANGBAR ASSEMBLY
9 TOOTH SPIKE BAR ASSEMBLY
12" DIA X 90" REEL ASSEMBLY

Figure 2-60: Chopper/Spike/Reel Placement 8550-43' RH

Assembly Instructions

It is very important that your new 8550 Series Finisholl be properly assembled, adjusted and lubricated before use. Illustrations in this section show proper assembly procedures. Remove paint from grease fittings. Replace any grease fittings that are damaged or missing. Be sure to return screws, clips, etc., to their original locations.

To insure alignment of assemblies, **leave the nuts loose until completion** of final assembly. Use lock washers or flat washers as specified. Spread all cotter pins.

After completion of final assembly, **tighten all nuts evenly** to prevent misalignment, distortion or binding. Tighten all screws and nuts to the recommended torques shown in **Table 2-1 and Table 2-2**.



WARNING

Do not attempt to lift heavy parts (such as the frame, rock shaft, and pull hitch) manually. Use a hoist or a forklift to move these parts into position.



DANGER

To prevent accidental lowering:

- 1. All hydraulically elevated equipment must be locked out using the cylinder lockouts.**
- 2. Lower equipment to the ground while servicing or when it is idle.**

Failure to take measures to prevent accidental lowering may result in serious personal injury or death.



CAUTION

Be sure to bleed the hydraulic system of all air in lines after installation. Failure to bleed the system of all air can result in permanent equipment damage.

Frame and Hitch Assembly

IMPORTANT

Read all safety precautions at the front of the section before attempting any of the following procedures.

Bolt the two center frame halves together using 3/4 x 2 GR 8 hex screws and 3/4 locknuts. - Leave loose until lift is installed

1. Place the center frame assembly on stands approximately 36" high (See Figures 3-2.) The assembly area should be a large level area of sufficient size to accommodate the finishroll when fully assembled.
2. Install center shank mount, 3/4 x 5-1/2 and 3/4 locknuts as shown.



WARNING

Do not attempt to lift heavy parts (such as the frame, center lift, and pull hitch) manually. Use a hoist or a fork lift to move these parts into position.

3. Slide the center lift assembly under the center frame (See Figure 3-3.) Install the four UHMW 4in bearings on the center lift, and two on each end. Slide the lift cap bearing on each end of the center lift. Raise the center lift assembly into the center frame assembly and secure the inner, blue lift cap bearings and outer, lift bearing mounts with 3/4 x 2 GR 5 hex screws and 3/4 locknuts. Make sure the lift is still able to turn after all bolts have been tightened.
4. Connect the rod end of each lift cylinder to the mounting ears on the center lift, with bushing between cylinder clevis, secure with flat washers, pins and spring slotted pins.
5. Install the tire and wheel assemblies on the center frame, either duals or single tire/wheel assemblies.
6. If using duals install tire scrapers as shown (See Figure 3-3.) (See Figure 3-5) for proper scraper placement.
7. Make sure that all mounting surfaces are clean and free of rust, dirt or paint. A wire brush may be used to clean these surfaces.
8. Position the inner disc wheel over the studs, being careful not to damage the stud threads. Make sure that the disc wheel is flat against the mounting surface. There will be a wheel spacer on the hub and it needs to be mounted between the hub and the inner wheel.

NOTE

Do not put hub spacer outside of wheel.

9. Install the flange nut and tighten to 50 foot-pounds using the sequence in. Then tighten to full torque of 450-500 ft./lbs (See Figures 3-1.).
10. Torque will drop after the first 10 hours of operation. Check the nuts for proper torque after this interval and re-tighten them.

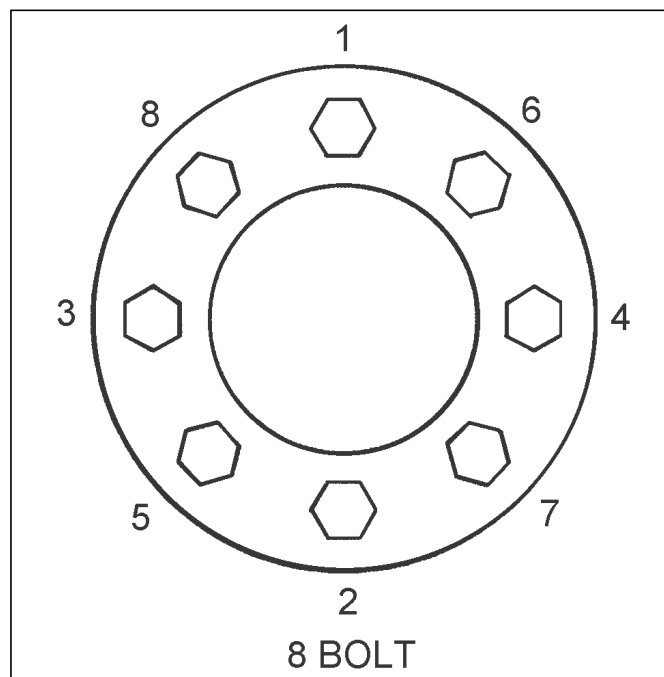

Figure 3-1: Stud Tightening Sequence

11. Attach the rear of the hitch to the front of the center frame using hitch pins, 1/8 hex nuts, and 1/2 x 2-1/4 solid pins. The pins will be installed in the frames. (See Figure 3-4.)
12. Install the 10,000 tongue jack in the forward mounting tube and rotate to parking position to support the front of the hitch.
13. Attach the rear mount of the depth control tube to the mounting ear on the center lift assembly using 3/8 x 1-1/4 bolts and 3/8 locknuts.
14. Attach the rear of the leveler assembly to the mounts on the main lift using a hitch pin. The pin is installed into the lift, and use 2, 1-1/2 machine washers per side to keep leveler centered, and 1 locknuts. For normal conditions, install leveler spring to lift in the upper hole.
15. Visible threads at the top and bottom of the radius rod should be nearly equal. Fasten the radius rod assembly to front of the hitch and top of the pivot link with 1-1/4 x 8 bolt, 1 lock washer and nut.

16. Insert a 3/4-10 x 7 hex head cap screw into the hose holder tube on the right side of the hitch from the bottom side so the threads point upward. Hold in place with a 3/4 prevailing torque flange nut with the flange pointing upward as well. Do not tighten this cap screw, so the hose holder bracket may pivot freely in this joint.
17. Slide the hose holder bracket over the screw and secure with another 3/4 prevailing torque flange nut.
18. Install a 3/8-16 x 3-1/2 all-thread screw in the front of the hose holder bracket and secure with a 3/8-16 hex nut. Insert the bolt from the bottom so the threads point upward.
19. Slide the hose holder clamp over the 3/8" screw and loosely start the wing nut on top of the clamp. Hydraulic hoses will be routed through the clamp after assembly.
20. Install fold cylinder mounts to the frame using 3/4-10 x 5-1/2 bolts and lock nuts. Install fold cylinder mount doubler plates to mount plates using 3/4-10 x 6-1/2 bolt and the tubular shaped smv mount.
21. Install the wing stabilizers to the fold mount plates using 3/4-10 x 5-1/2 bolts and lock nuts. Install the wing locks to the stabilizer tubes using 3/4-10 x 4-1/2 bolts and lock nuts.

NOTE

Install all of the bolts in steps 21 and 22 pointing toward the center of the machine to allow clearance for folding.

NOTE

The clamp has two sides, so that extend hoses can be located on one side and retract hoses can be located on the other side for reference.

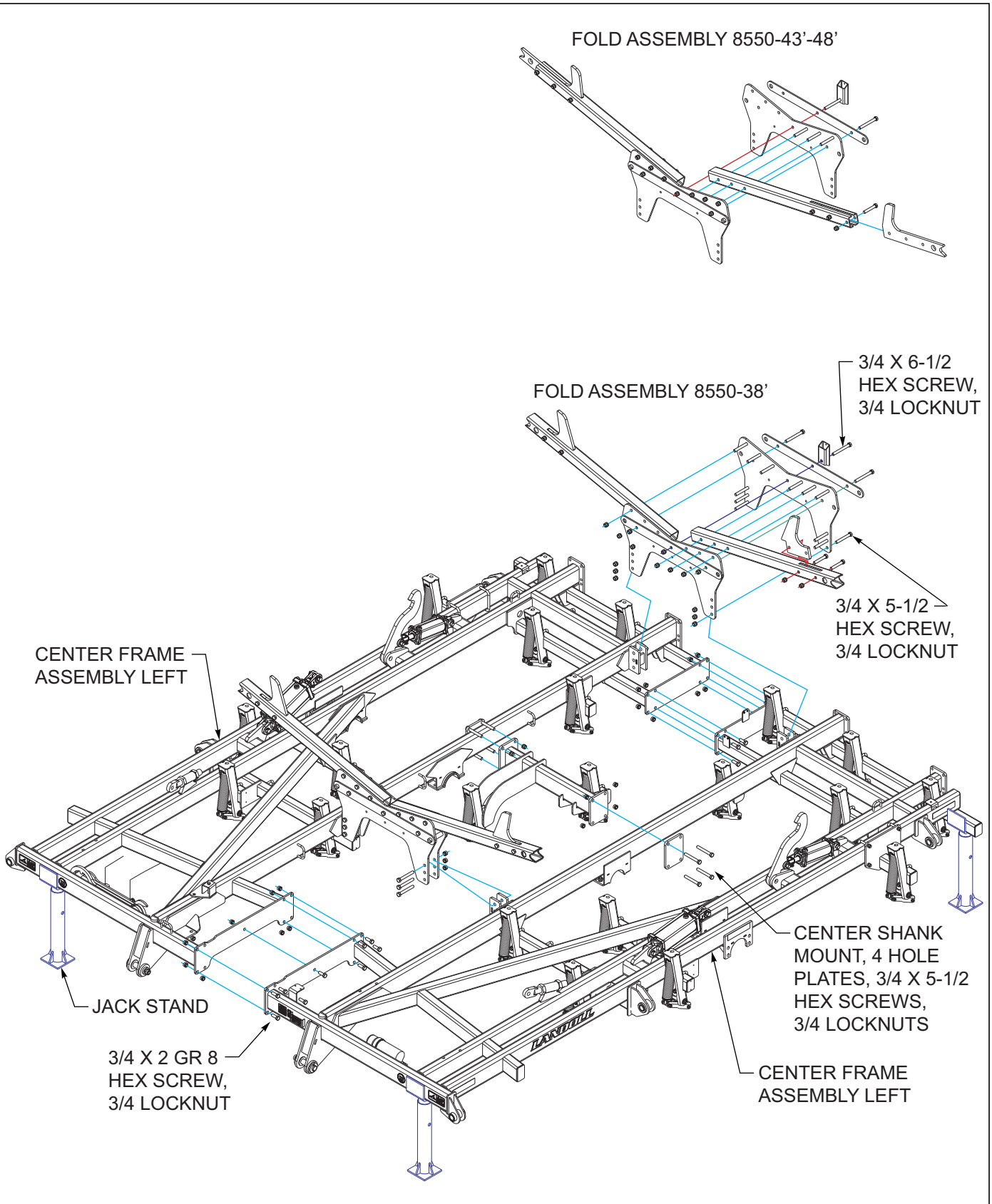

Figure 3-2: Center Frame Assembly

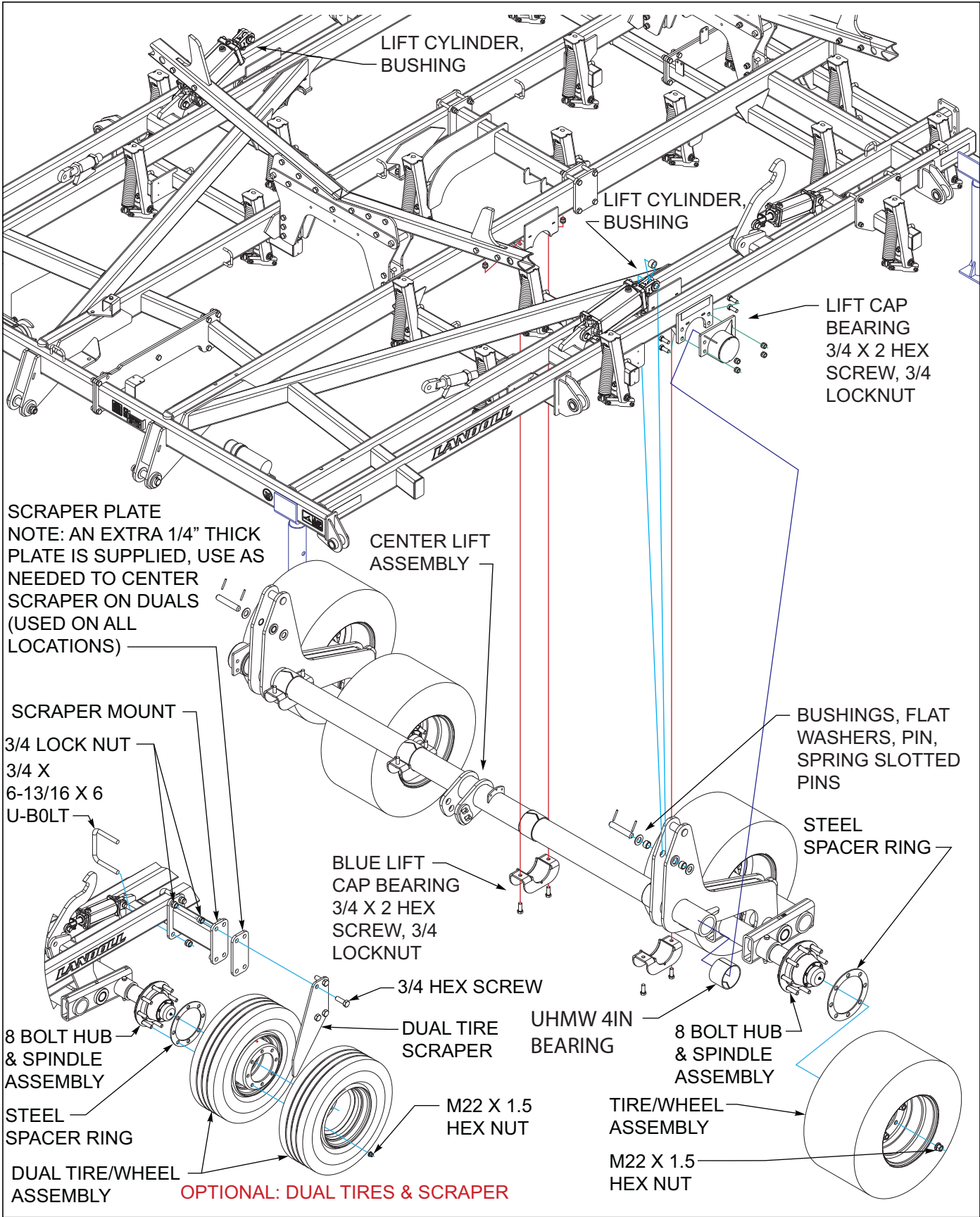

Figure 3-3: Center Frame Assembly Lift

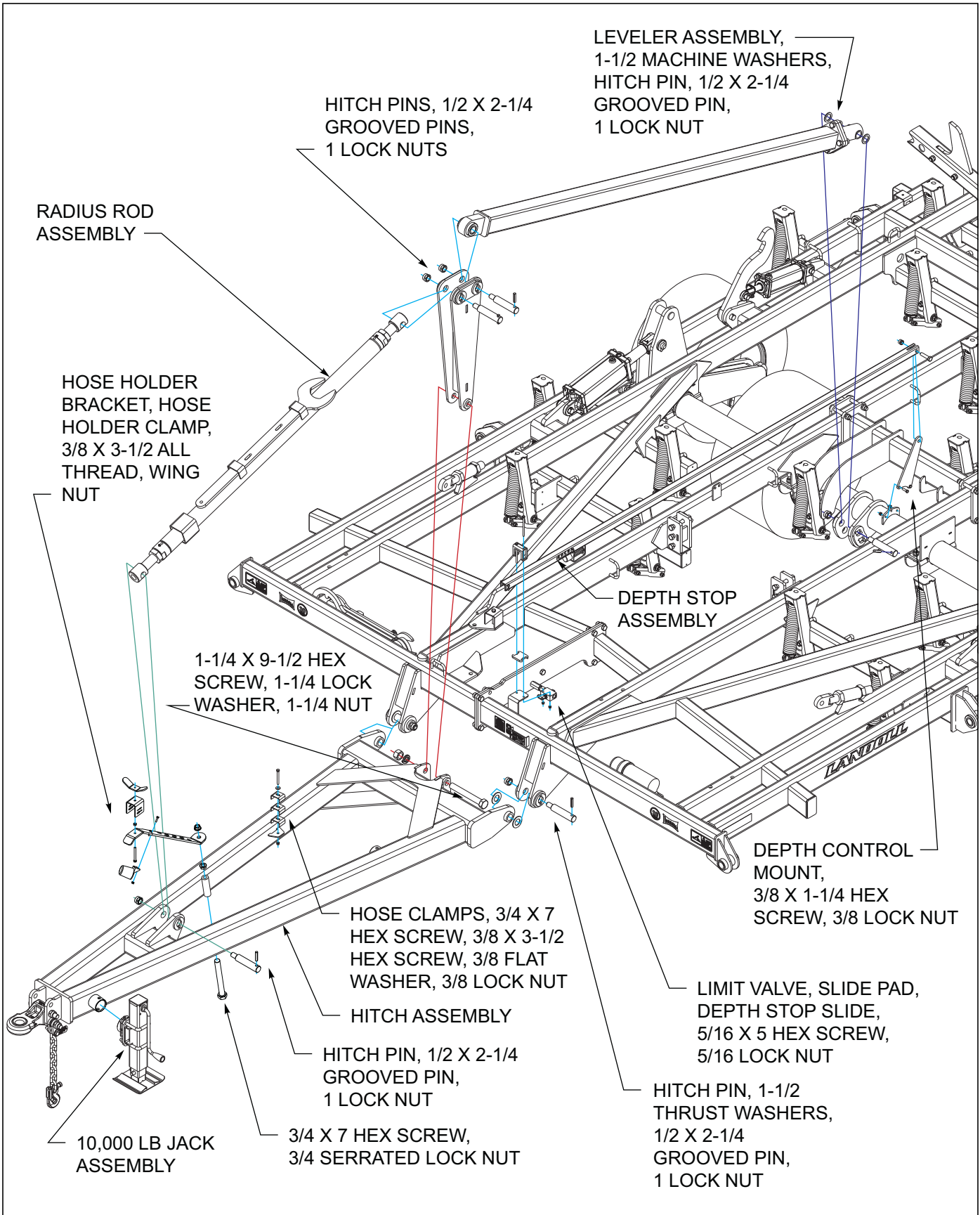

Figure 3-4: Hitch & Leveler Assembly

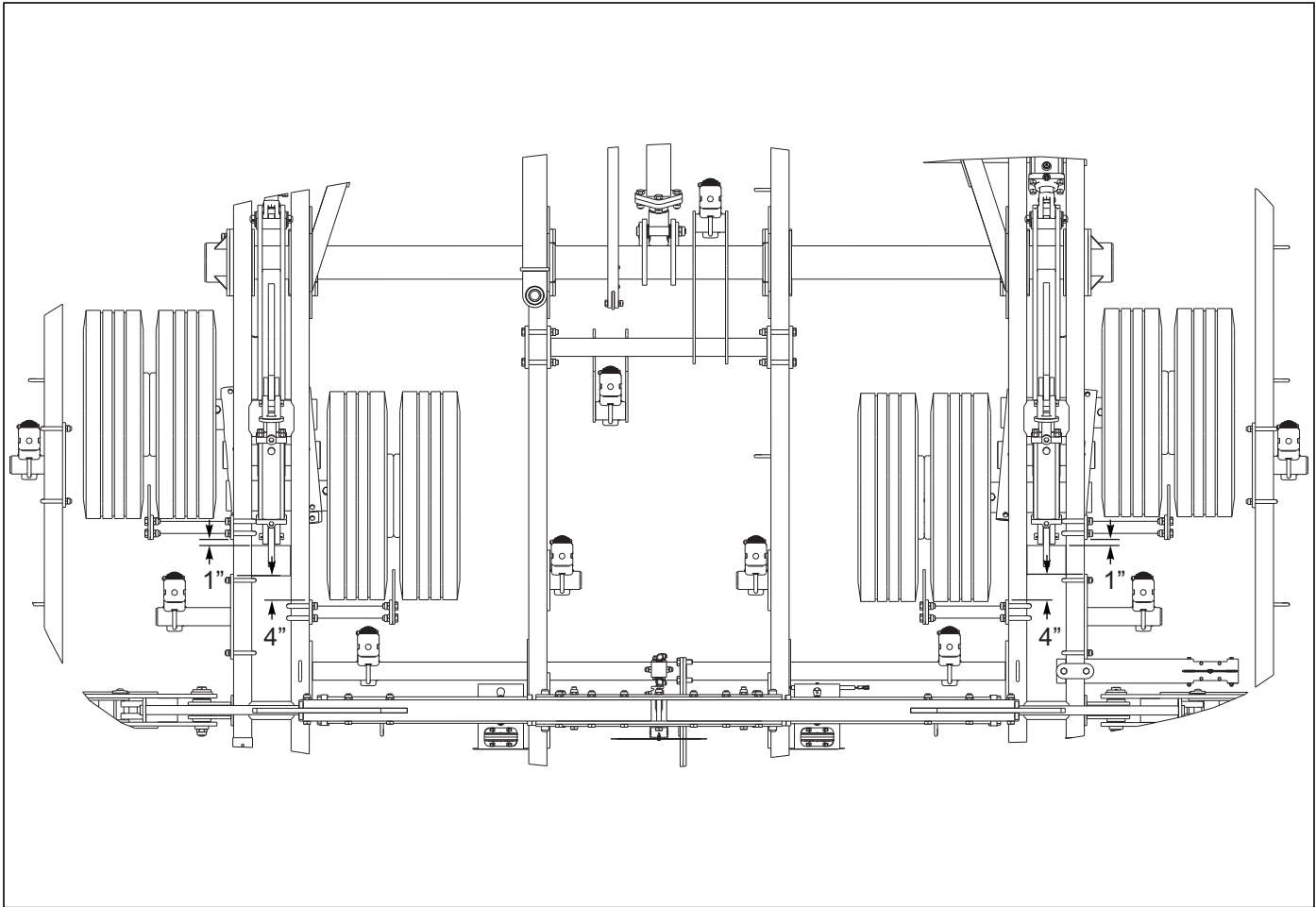

Figure 3-5: Dual Scraper Placement

LED Light and SMV Bracket Installation

1. Assemble the SMV mount, SIS mount, SIS decal, SMV emblem, with 1/4 x 1 hex bolt and 1/4 lock nut (See Figure 3-6.)

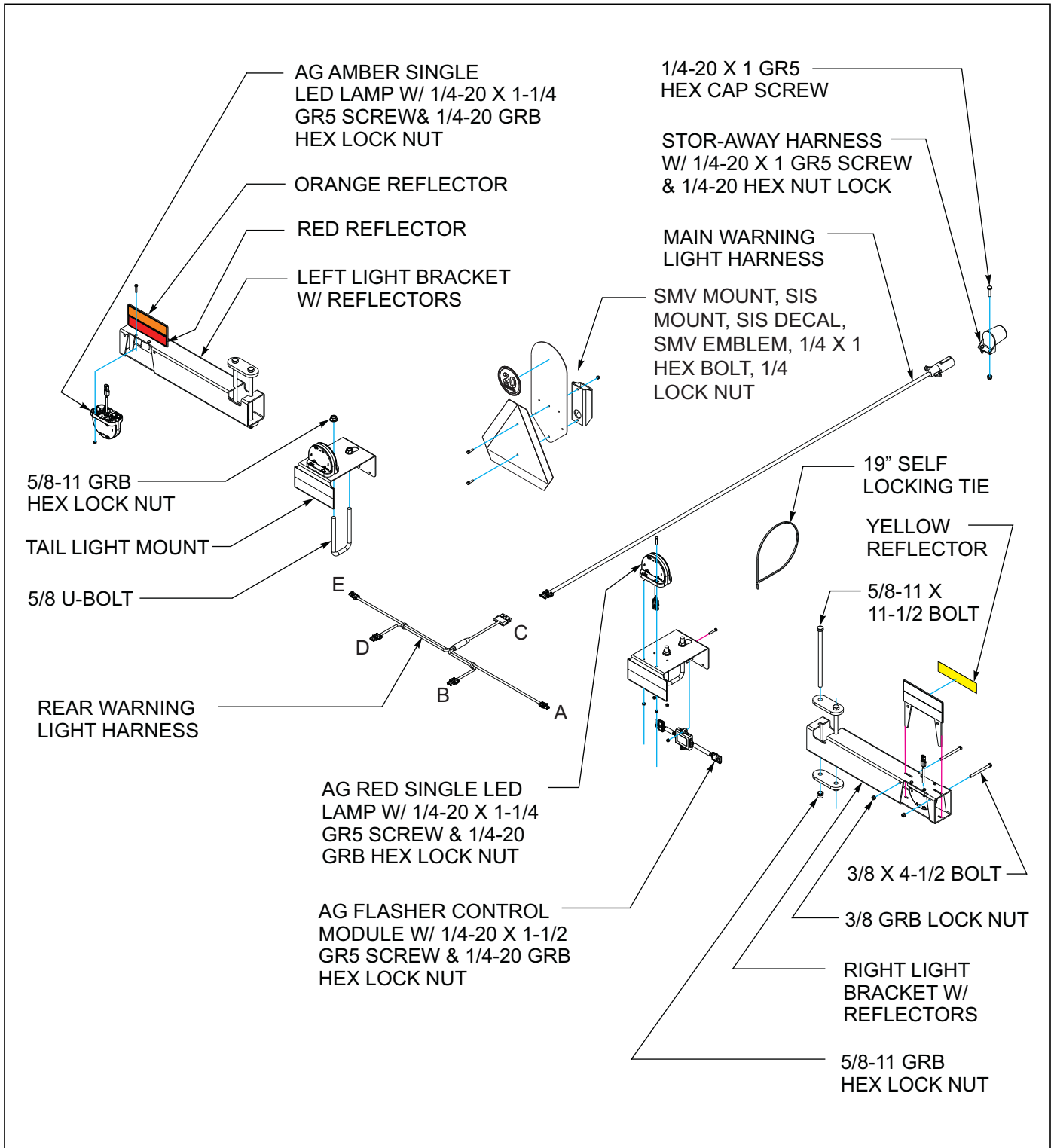

Figure 3-6: LED & SMV Bracket Installation

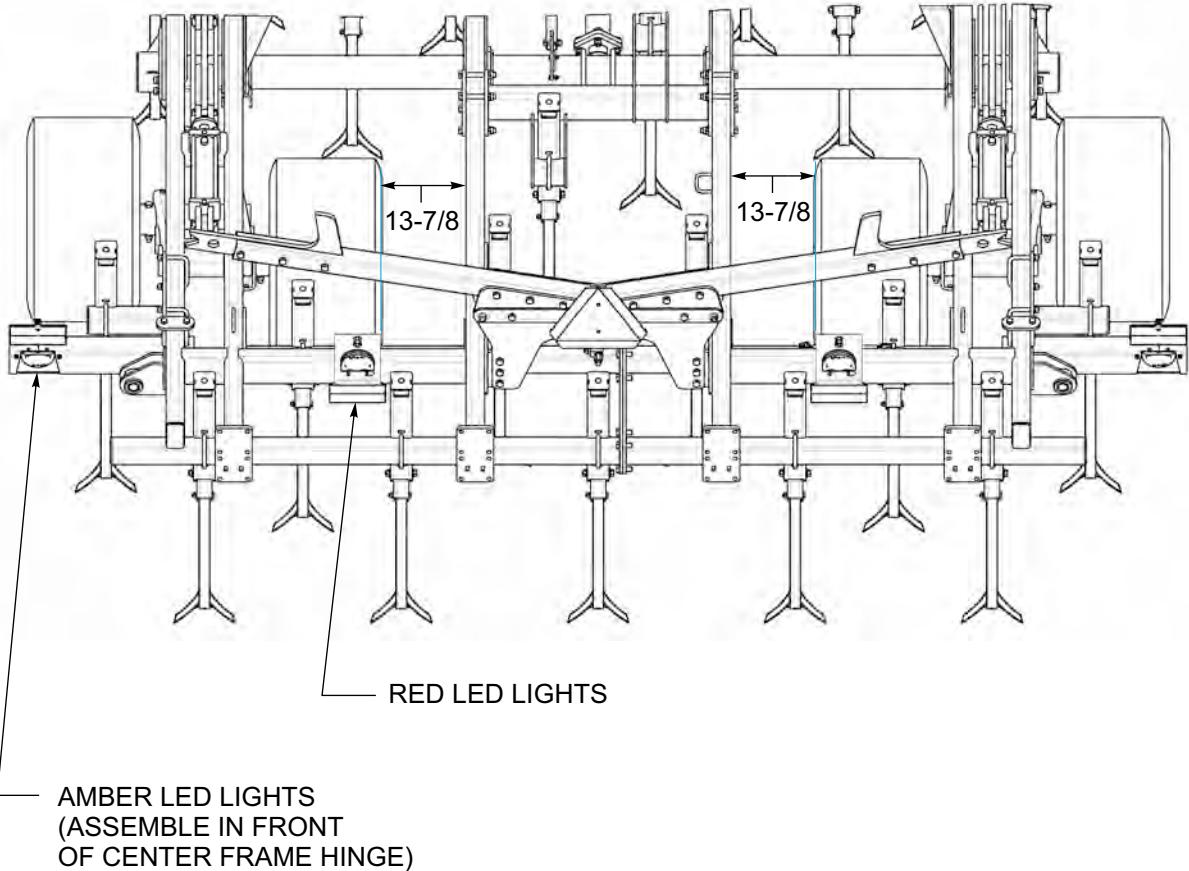

Figure 3-7: LED Light Placement

7-PIN CONN.	4-PIN TOWER	CIRCUIT	WIRE COLOR
1	D	GROUND	WHITE 
2	-	WORK LAMPS	BLACK 
3	B	LEFT FLASHING & TURN	YELLOW 
4	-	STOP LAMPS	RED 
5	A	RIGHT FLASHING & TURN	GREEN 
6	-	TAIL LAMPS	BROWN 
7	C	SWITCHED POWER (12 V)	BLUE 

MAIN WARNING LIGHT HARNESS - WIRING CHART

	1	2	3	4	5
	2-PIN TOWER	3-PIN TOWER	6-PIN SHROUD	3-PIN TOWER	2-PIN TOWER
 BLACK LEFT TURN			A	C	
 WHITE GROUND	A	A	B	A	A
 BROWN TAIL LIGHT		B	C	B	
 YELLOW LEFT TURN			D		B
 GREEN RIGHT TURN	B		E		
 RED RIGHT TURN			F		

REAR WARNING LIGHT HARNESS - WIRING CHART

Figure 3-8: LED Light and SMV Harness Wire Designations

Inner Wing Installation

1. Assemble the inner wings to the center frame as shown in **Figures 3-9 & 3-10**. Installation of the front hinge pin as shown **Figures 3-9 & 3-10** with thrust washer on both ends and two in the middle is recommended first. Then the middle hinge pin and finishing with the rear pin. The center and rear hinge pins will only have thrust washers on the front side of the center frame hinge ear.
2. Assemble the tire and wheel assemblies to the wing frames. Torque to 85 to 100 ft./lbs. Tires will be installed with the valve stem facing outward.

3. Assemble the wing stabilizer mounts as shown in **Figures 3-9 & 3-10** along with the wing lock assembly to the front mounts.

IMPORTANT

Note the orientation as the rubber bumper must be toward the outside and the 1/2-13 x 3-1/2 hex head cap screws must be inserted from the bottom through the wing rest mount and rubber bumper and the flat washers and hex lock nuts located on top.

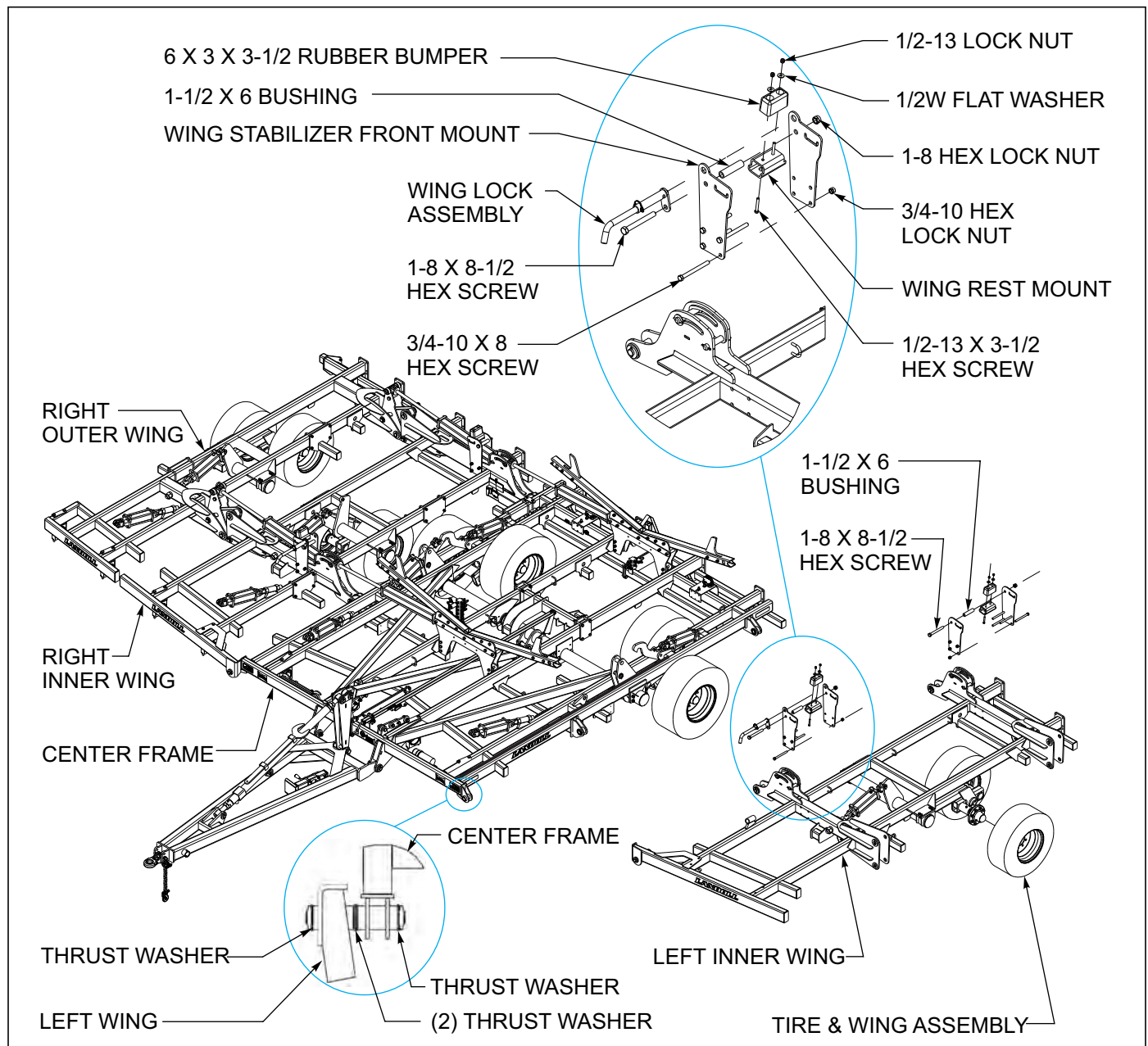

Figure 3-9: Inner Wing Installation - 38'

ASSEMBLY INSTRUCTIONS

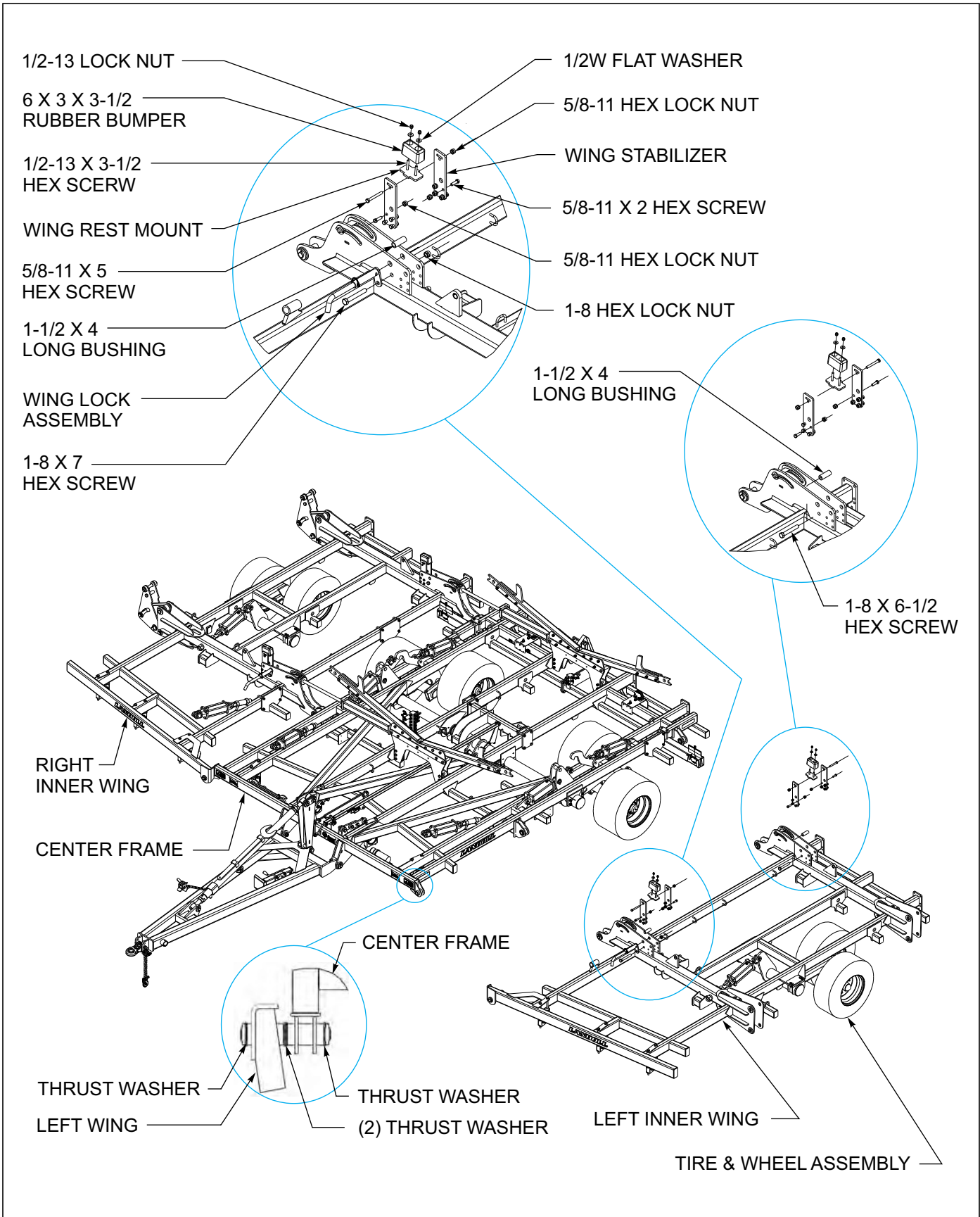

Figure 3-10: Inner Wing Installation - 43' & 48'

Outer Wing Frames

1. Assemble the outer wings to the inner wing frames as shown. Install the double hinge and locks to inner wings with the upper thrust washer to the rear of the machine using hinge pins and 1-1/4-7 hex lock nut (See Figures 3-12 and 3-13.) Install the bottom wing lock pins on the inner wings using 1-3/4 x 9-3/4 pins with snap rings. Install two fold links per hinge, placing them over the bushing of the double hinge and locking them to the bottom pin. Insert 1-8 x 6-1/2 hex head cap screw, wing fold spacer, and 1-8 hex lock nut to keep fold links stable while installing outer wing.
2. Attach outer wing with thrust washer toward front of machine (See Figures 3-11 thru 3-13.) Install 1-3/4 x 9-3/4" through outer wing and fold locks. Install 2-13/16 x 1-13/16 washers and snap rings to secure pins.
3. Assemble the tire and wheel assemblies to the wing frames. Torque to 85 to 100 ft./lbs. Tires will be installed with the valve stem facing outward.

NOTE

All tire/wheel assemblies are mounted with the valve stem facing outward.

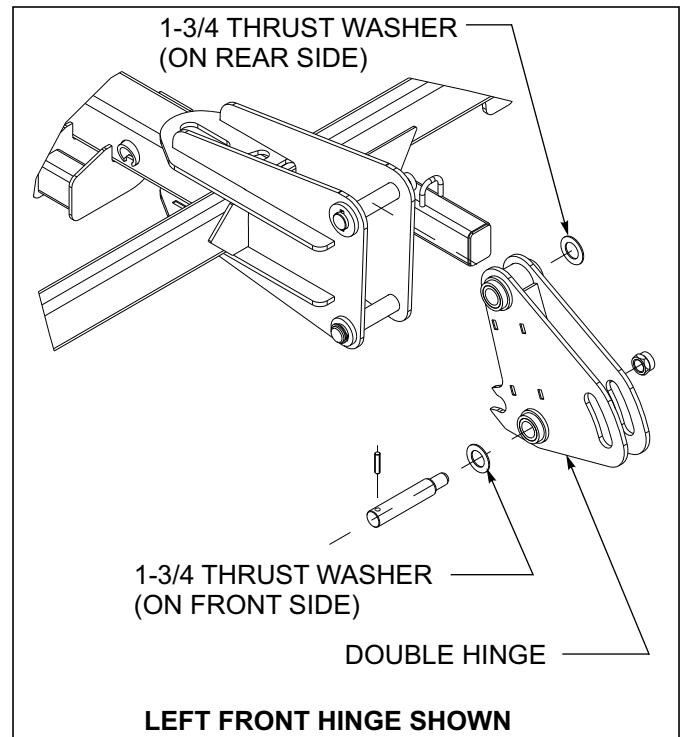

LEFT FRONT HINGE SHOWN
Figure 3-11: Thrust Washer Locations

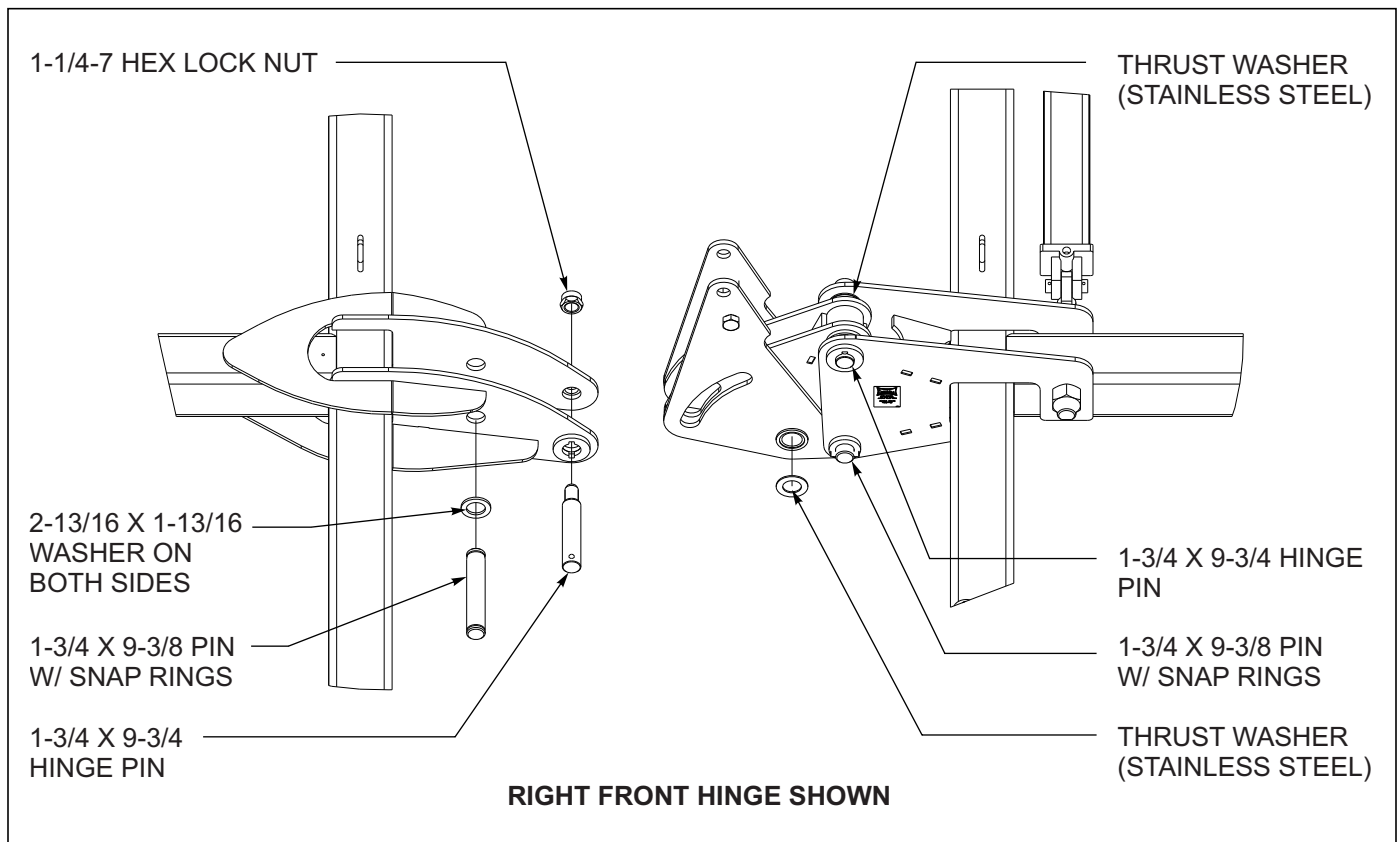

RIGHT FRONT HINGE SHOWN
Figure 3-12: Outer Wing Frame Hinge Assembly

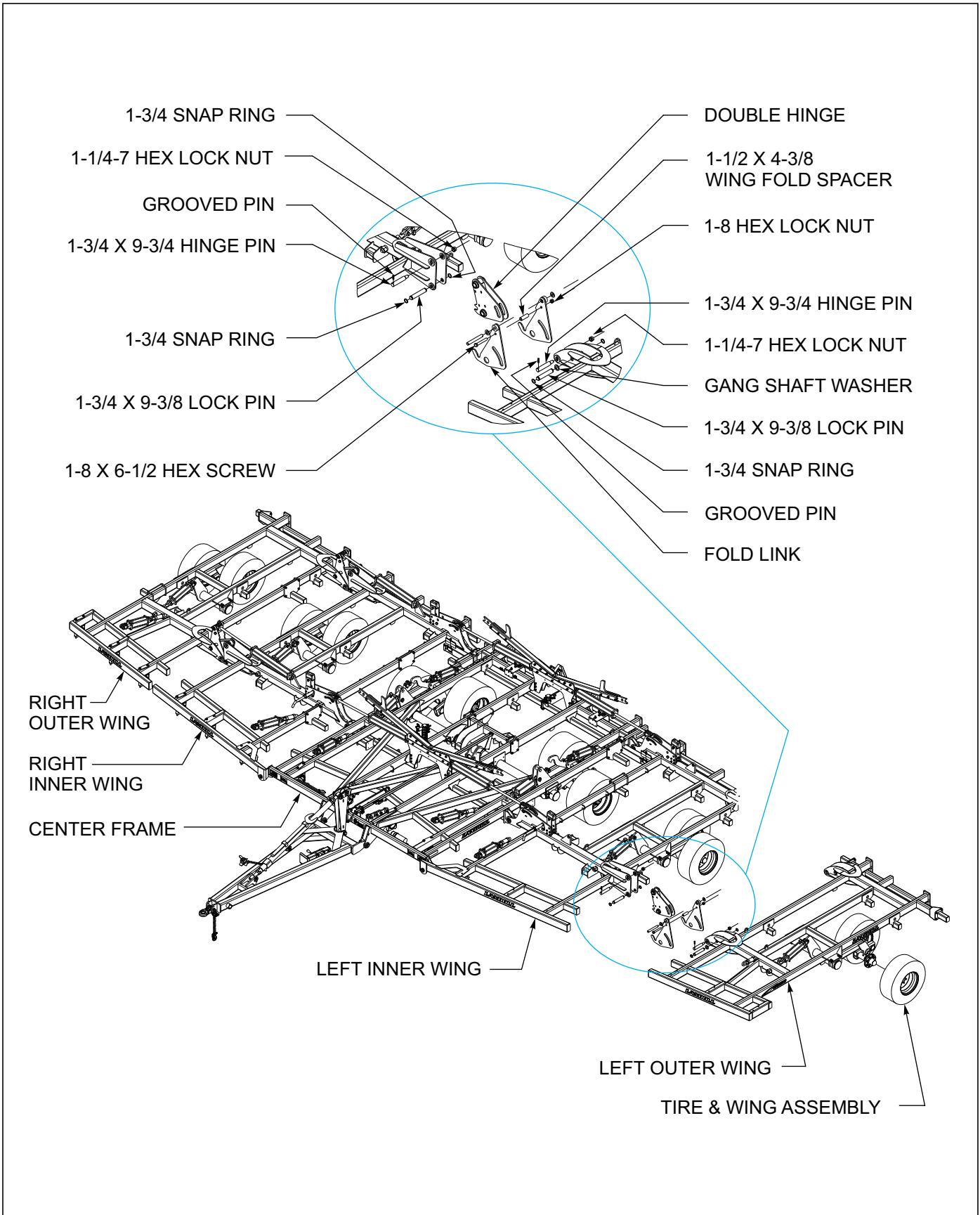

Figure 3-13: Outer Wing Installation

Disc Gang Installation

1. Assemble the center frame disc gangs to the center frame using cast bearing halves, plastic bearing inserts, two hole clamp plates, 3/4-10 x 15 bolts, 3/4-10 x 16 bolts, and 3/4 lock nuts.
2. Align the cylinder mounts on the disc gang assemblies with the mounts on the center frame to properly position the gangs. The 3/4-10 x 16 bolts will be used on the inner tubes of the frame and the 15" bolts will be used on the outer tubes. There will be clamp plates used on the top and bottom of the frame tubes. On the right side of the frame the inner top clamp plate will be the one with a separate hole in it to mount a hydraulic hose clamp to (See **Figures 3-16 and 3-17.**)
3. Assemble the center gang lift at the front of the center frame on the bottom side of the mounting plates with cast bearing halves, plastic bearing inserts, and 3/4-10 x 8" bolts and 3/4 lock nuts.
4. Assemble the ball joint links to the center gang lift and to the center gangs as shown in (See **Figures 3-14 & 3-16.**) Use 1-8 x 4" long bolts and lock nuts to secure the ball joints to the center lift and the gang assemblies. Use 3/4-10 x 3" long bolts, hardened washers, and lock nuts to assemble the links together. Assemble links as shown with the front link to the inside.
5. Assemble the wing frame disc gangs to the wing frame using cast bearing halves, plastic bearing inserts, two hole clamp plates, 3/4-10 x 15 bolts, and 3/4 lock nuts.
6. Align the cylinder mounts on the disc gang assemblies with the mounts on the center frame to properly position the gangs. All of the mounting locations except the inner most wing location will have two hole clamp plates on the top and bottom of the frame (See **Figure 3-17.**)
7. Install the hydraulic cylinders for the gangs by attaching the base end of the cylinder to the adjustable mount on the frame and the rod end to the gang assembly with the ports pointing upward. The center frame will have 4 x 8 cylinders, the inner wing will have 3-3/4 x 8, and the outer wing 3-1/2 x 8 cylinders. Each cylinder will have regular 90 degree fittings installed into them facing to the rear of the machine. The outer wing cylinders will have a 1/16" restrictor (black fitting) installed into the rod end as shown in **Figure 3-17.**
8. Once the cylinders are installed, and are fully retracted- the gangs can be leveled. Measure from the bottom of the frame tubes that go from front to rear to the top of the disc blades and adjust the mount at the base of the cylinder to make this dimension 9" on each gang (See **Figure 3-15.**) Wrenches are provided on the center frame to adjust this with. After gangs are level, tighten the 3/4-10 x 3 bolts and 3/4 lock nuts in the slotted holes of the ball joint links on the center frame. This will keep the center frame gangs in time with each other.

NOTE

Do not tighten the 3/4-10 X 3 bolts in the slotted holes until the gangs are adjusted to level.

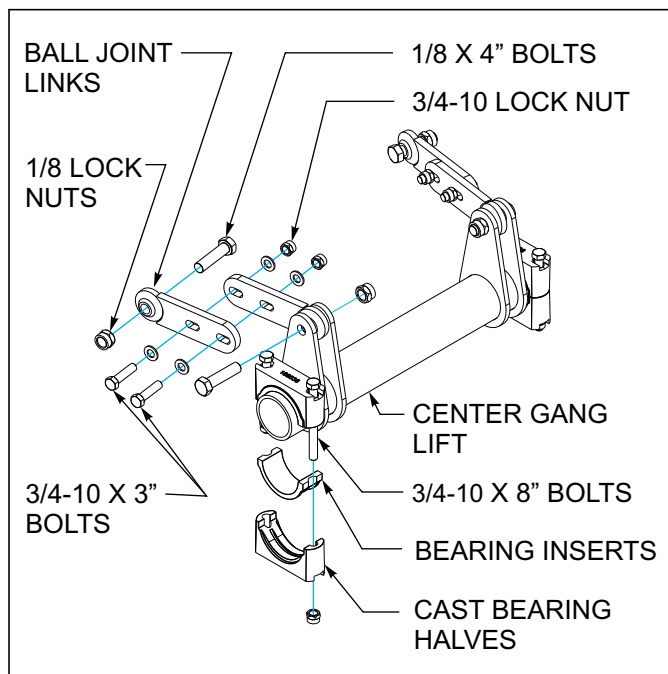

Figure 3-14: Center Gang Lift

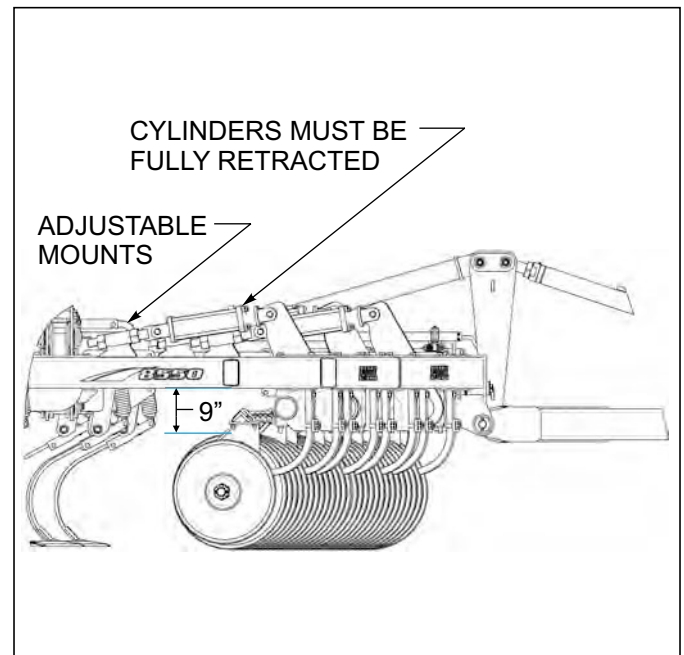

Figure 3-15: Disc Gang Operation

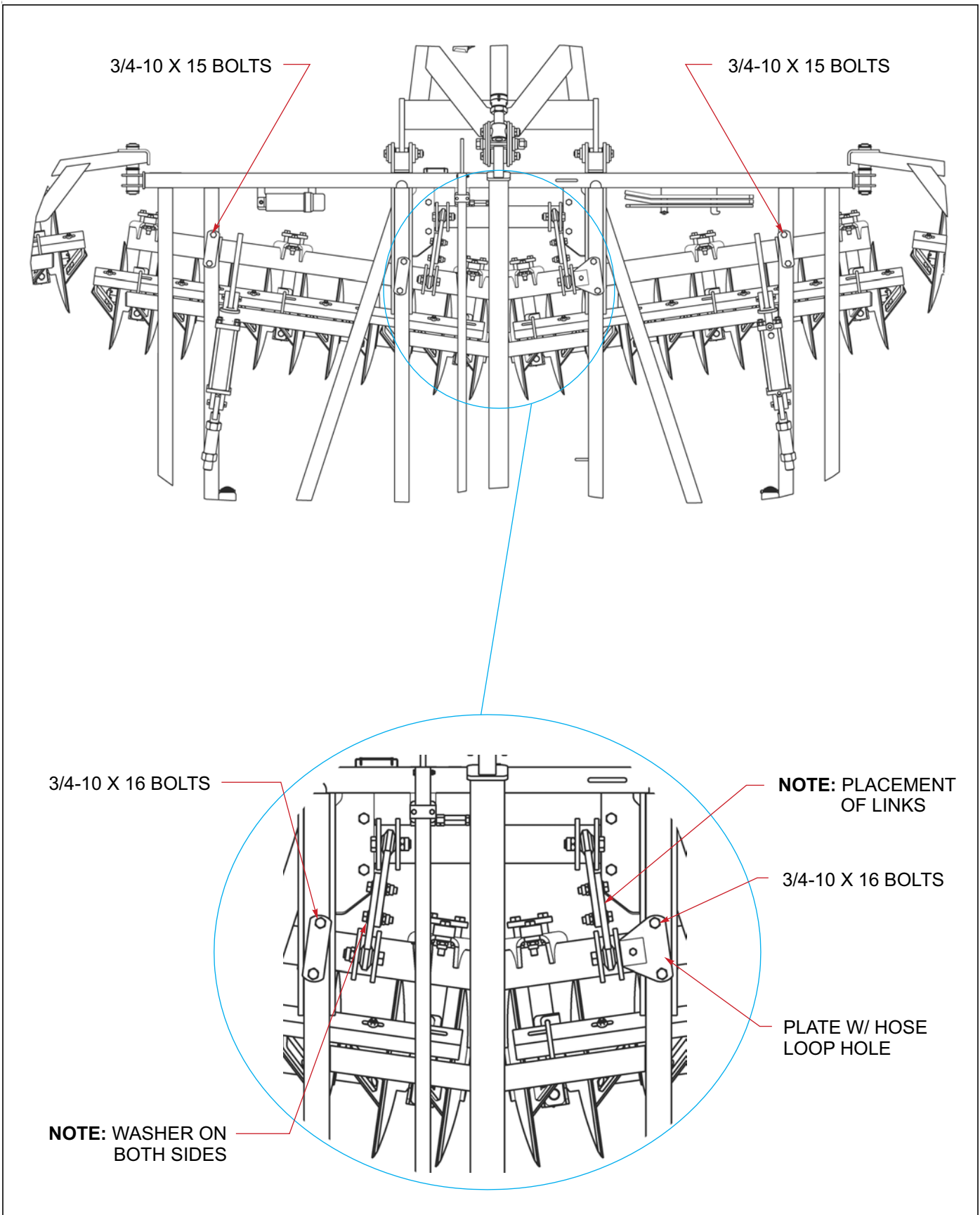

Figure 3-16: Disc Gang Installation (1 of 2)

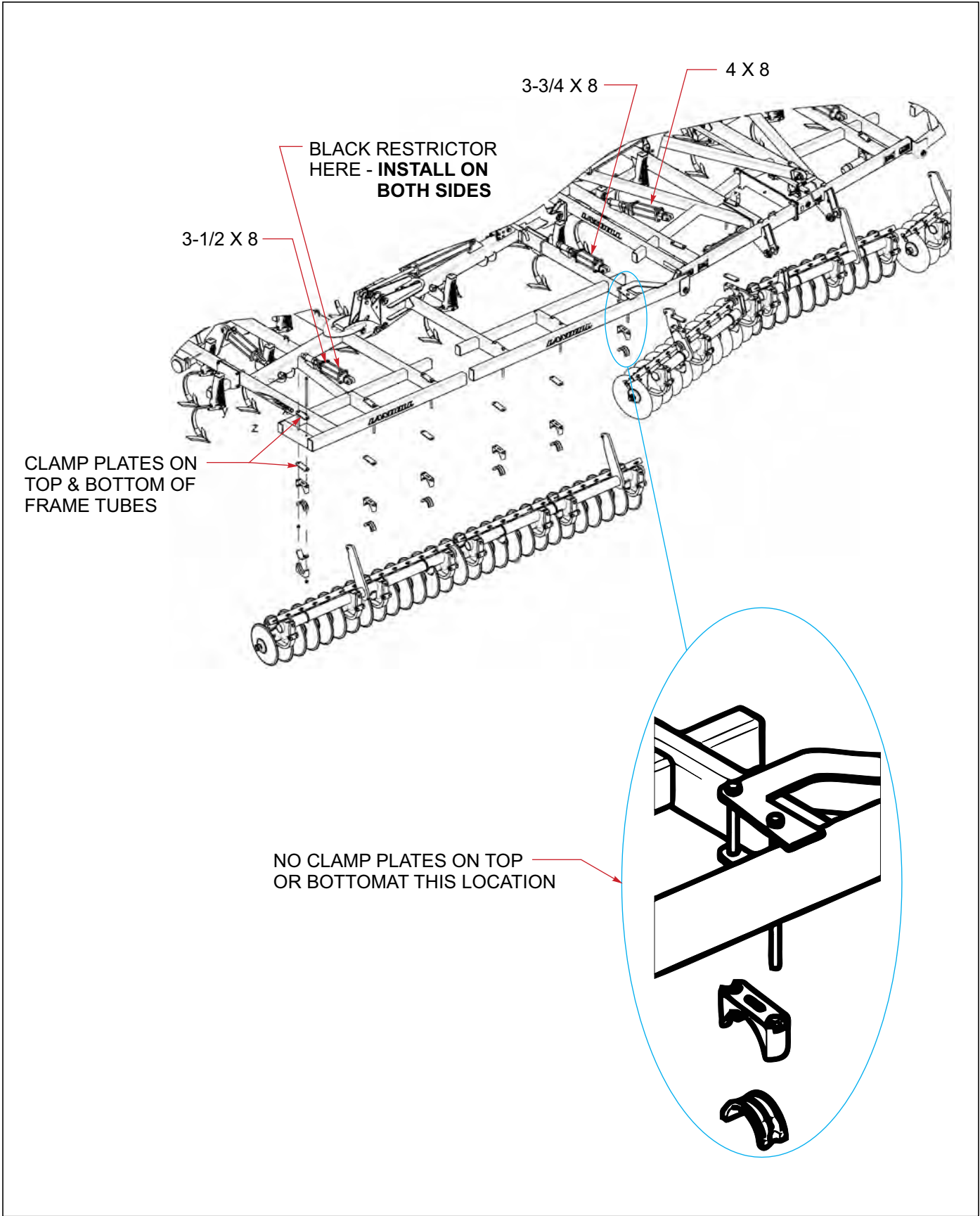

Figure 3-17: Disc Gang Installation (2 of 2)

Optional Gang Shield Assembly

Assemble the adjustable brackets and spacers to the center and wing frames with the wider hole spacing to the top. Recommended initial setting is to install the u-bolts, locking flange nuts, and spacer in the 4th and 6th holes from the front to mount the brackets to the frame. Attach the shields to the adjustable bracket in the 4th hole from the bottom using 5/8 x 2 bolts, backup plates, and 5/8 locknuts. There will also be locations where the shields overlap, attach them together with 5/8 x 2 bolts, 5/8 flat washers on each side, and 5/8 locknuts (See Figures 3-18 through 3-21.)

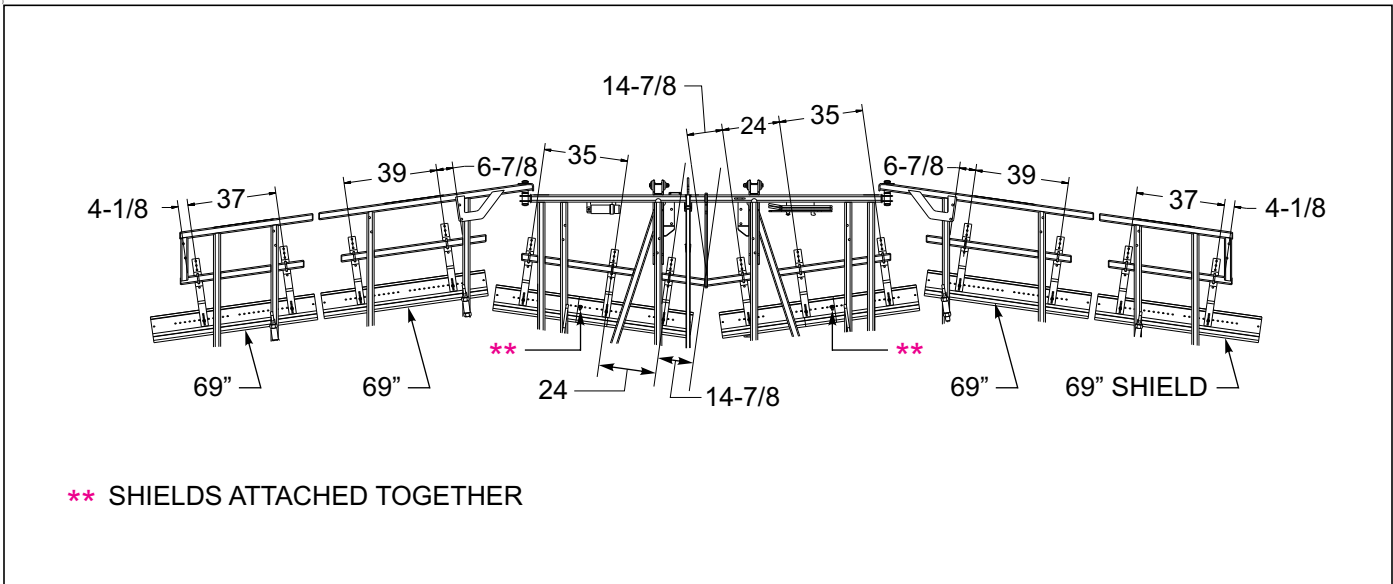

Figure 3-18: Gang Shield Installation - 38'

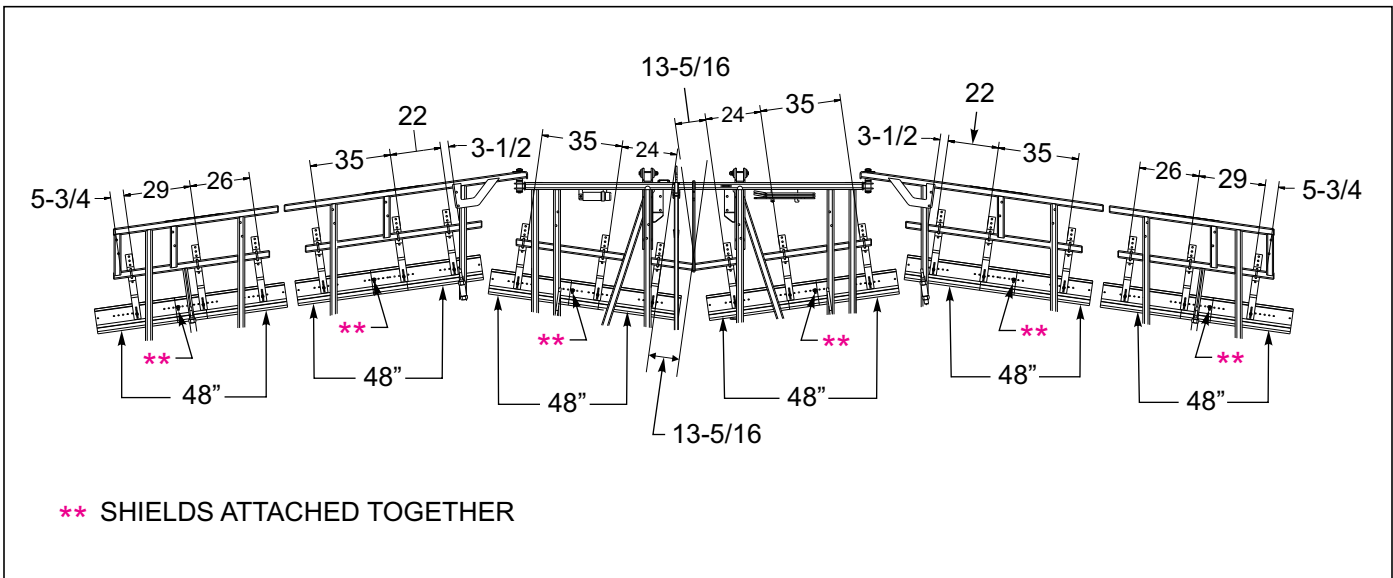

Figure 3-19: Gang Shield Installation - 43'

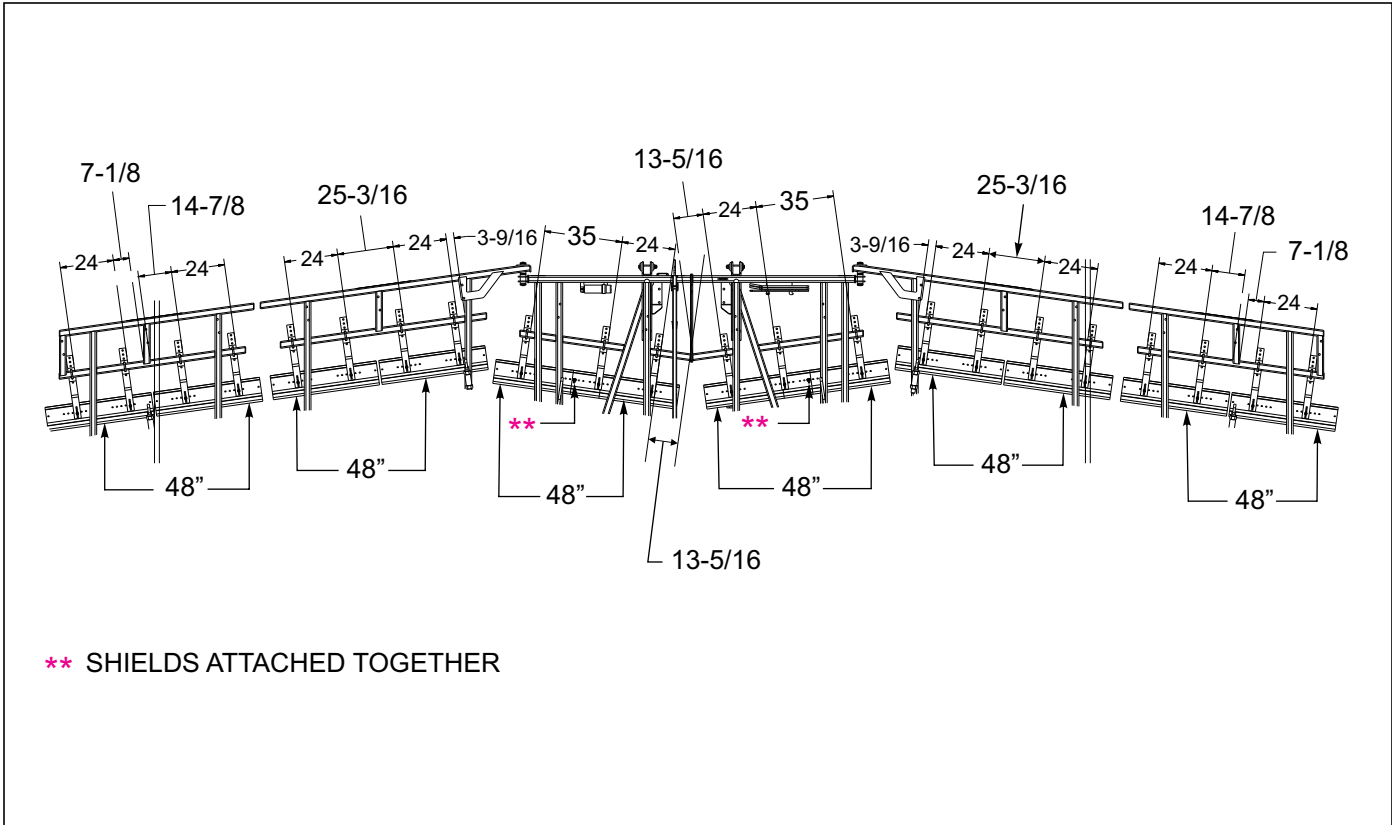

Figure 3-20: Gang Shield Installation - 48'

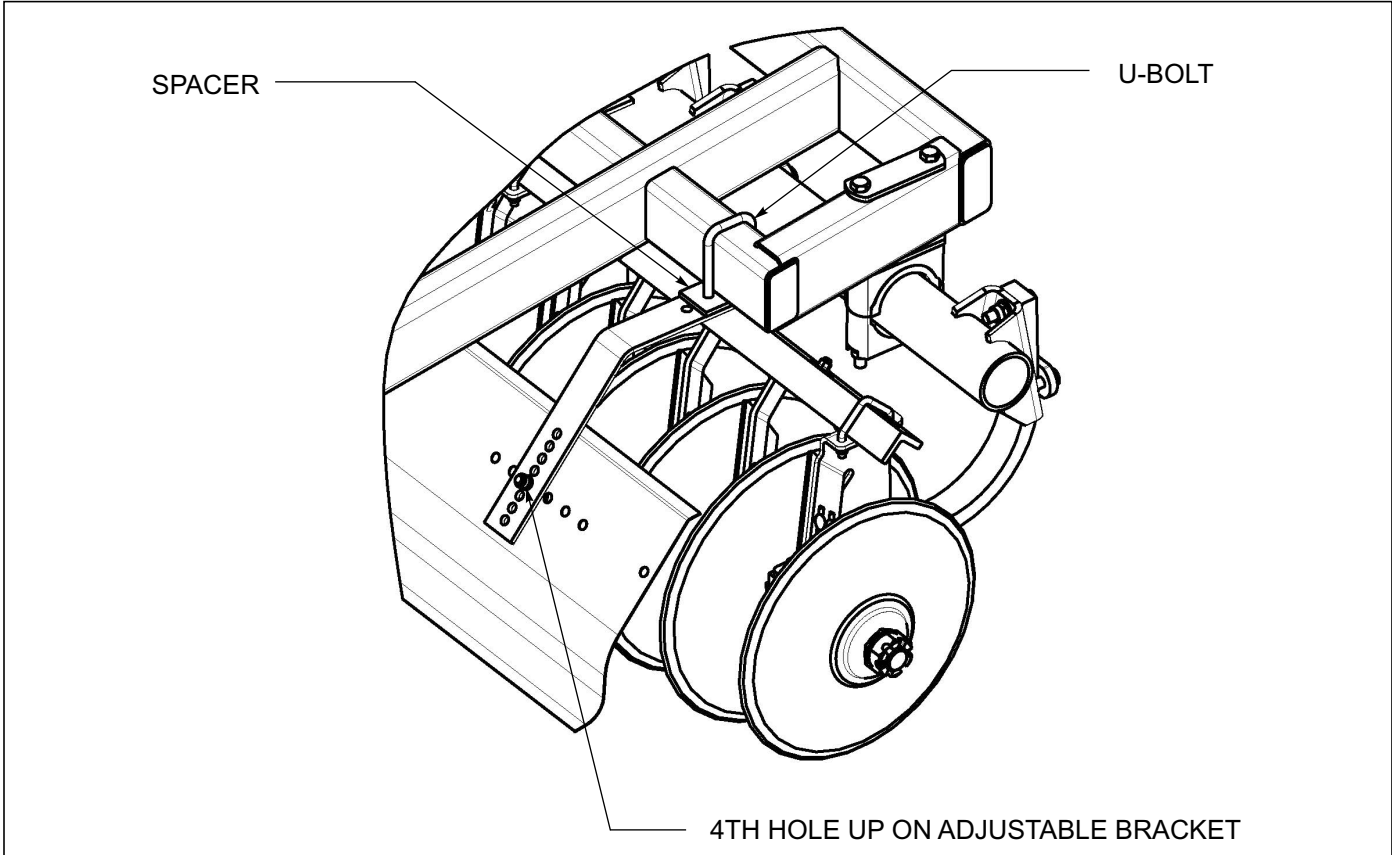

Figure 3-21: Gang Shield Adjustment

Disc Gang Reel Assembly (Optional)

1. Optional Disc Gang Reel Arm Assembly – (See **Figures 3-22**). Refer to the **Disc Gang Reel Layout drawings for proper placement** (See **Figures 3-23**). Attach reel arm assembly RH or reel arm assembly LH to frame. Position torsion spring in slot of spring retainer, secure with 5/8 x 5-11/16 x 6-3/4 u-bolts and 5/8 locknuts Attach reel assembly to reel arm assembly RH and reel arm assembly LH. Secure with 5/8 x 3-11/16 x 4-5/8 u-bolts and 5/8 locknuts. When all components are in positions shown (**See Figures 3-23**), all bolts may be tightened to specs.

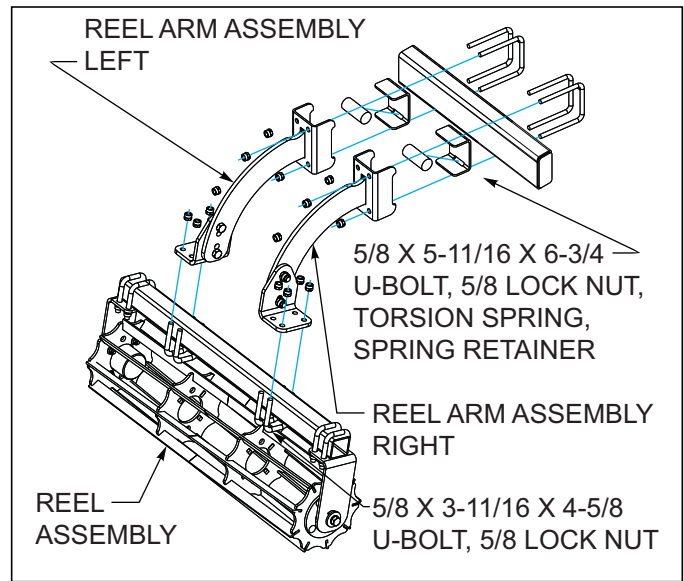
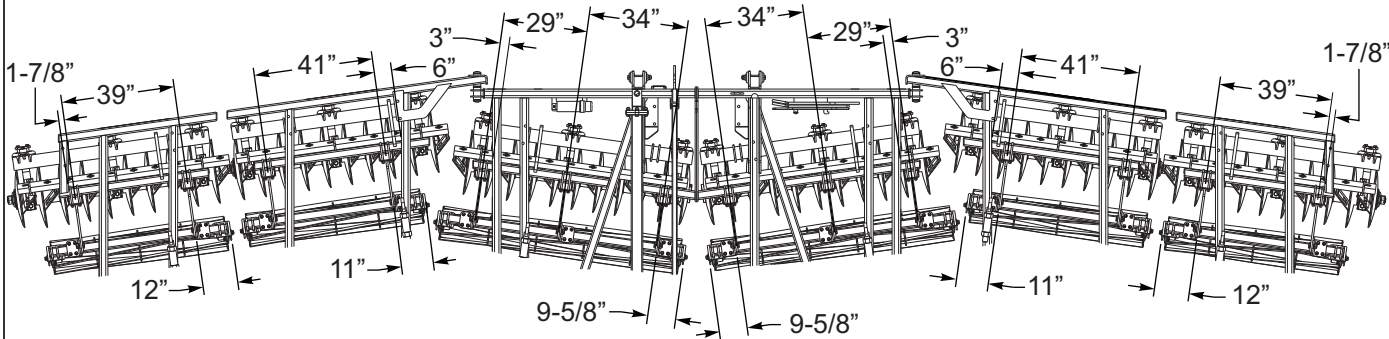
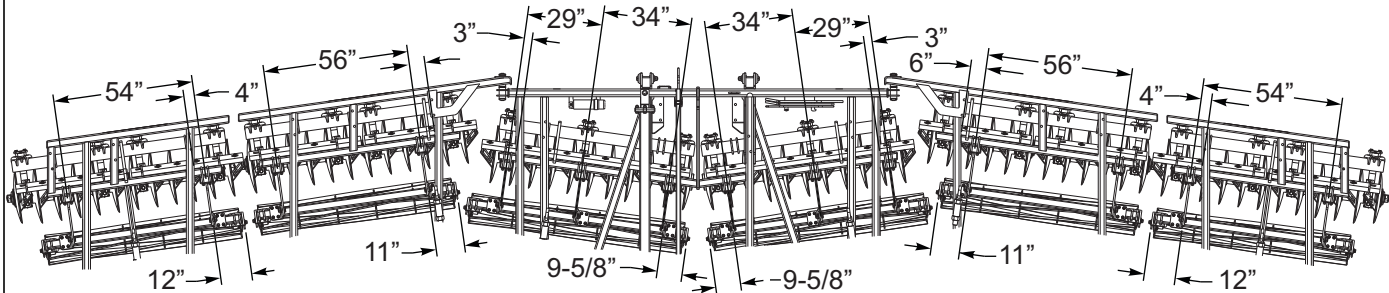

Figure 3-22: Disc Gang Reel Arm Assembly



REEL PLACEMENT
8550-38'



REEL PLACEMENT
8550-43'

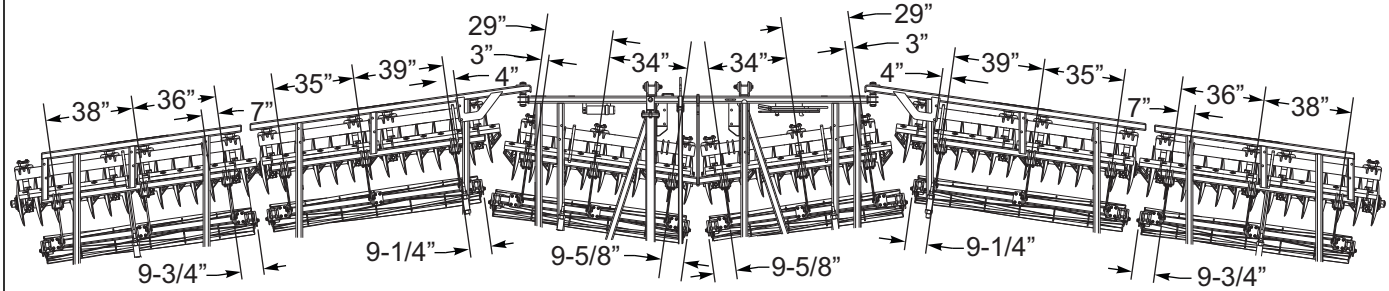

REEL PLACEMENT
8550-48'

Figure 3-23: Reel Assembly Placement

Hydraulic Installation

1. Install the hydraulic manifolds at the center and rear of the center frame to the mounts welded to the frames using 1/2 x 3-1/2 bolts and lock nuts. Loosely install hose clamps as shown with 1/2 x 4-1/2 bolts and lock nuts (See Figures 3-24 & 3-25.) On the front manifold, the top two ports are folding, the middle two are for hydraulic gangs, and the bottom two are for the lift system.
2. Install 90 degree regular adapter fittings in both ends of inner and outer wing lift cylinders. Install a tee into the base end of the master lift cylinders on the center frame and the fittings to install the relief valve onto the rod end (See Figures 3-32 thru 3-34.)



CAUTION

Restrictors are installed in the rod end of wing fold cylinders to prevent uncontrolled dropping of wings. Removal of these restrictors, or improper installation can result in series damage to the implement.

- a. Install adapters and restrictor into the limit valve as shown in Figure 3-28. The arrow on the restrictor should point away from the valve.
 - b. Route the hoses along the right side of the hitch, and through the hose loops provided along the frames. Wrap the two lift hoses with a blue hose wrap.
3. Install fold cylinders as shown in Figure 3-26. The 4-1/2 x 30 cylinders go onto the center frame, and the 4 x 30 cylinders go onto the wings. All cylinders are mounted with the fittings facing to the center of the machine.

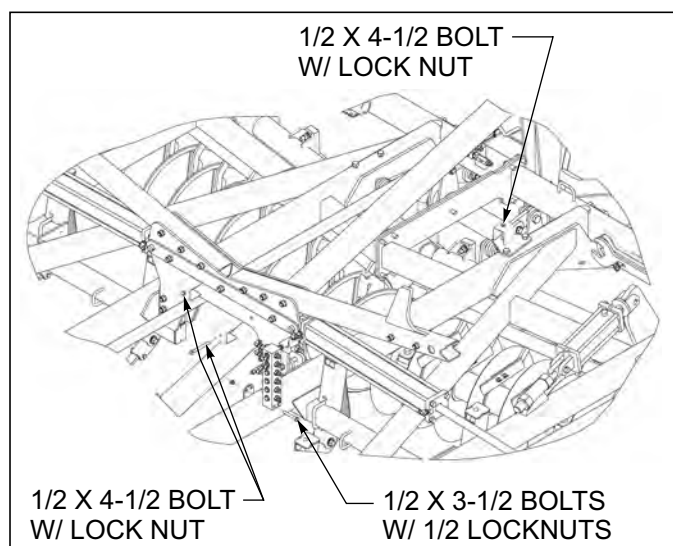

Figure 3-24: 8550 Front Manifold

NOTE

Rod ends of fold cylinders need to be left un-assembled until fold hydraulic system is fully charged with oil to prevent machine damage when folding the first time.

- a. See Figure 3-26 for proper pins and assembly of outer wing fold.
 - b. See Figure 3-27 for proper installation of fittings and hose routings. All fold cylinders have a black restricted fitting in the rod end only of each cylinder to prevent machine damage. Remove the (4) plain 90 degree fittings from the base end of the outer wing fold cylinders and install the (4) extra-long 90 degree fittings to allow the hoses to be installed when the cylinder is next to the wing stabilizers.
 - c. Wrap the two ends of the fold cylinders with yellow hose wrap.
4. Install hydraulic disc gang adjustment cylinders as shown in Figures 3-35 thru 3-37. The center frame uses 4 x 8 cylinders, the inner wing is 3-3/4 x 8, and the outer wing is 3-1/2 x 8. Cylinders are installed with the base end attached to the adjustable link on the center frame and the rod is attached to the gang mount. Regular 90 degree fittings are used in all locations except for the rod end of the wing cylinders, where a black restrictor fitting is used on both sides.
 - a. See Figures 3-35 thru 3-37 for proper hose routing.
 - b. Wrap the two hose ends with black hose wrap.
 - c. Install the hydraulic gang depth indicator on the right front center frame disc gang.
 5. Secure hoses into the (3) bolt on hose clamps. One is at the front of the center frame and the other two are on the back side of the front set of wing fold cylinder mounting plates (See Figure 3-24.)

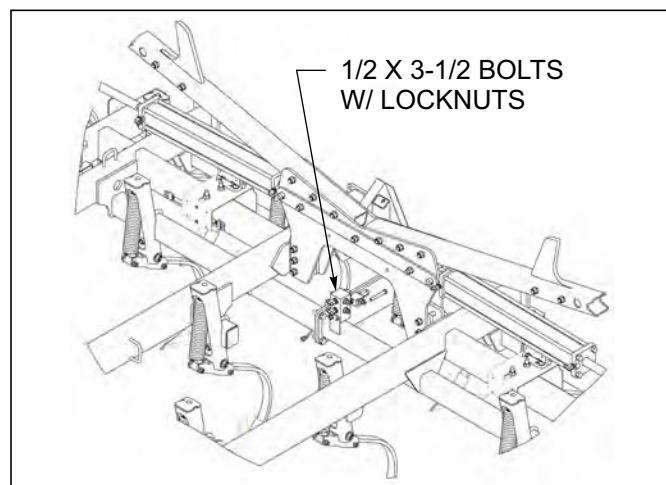

Figure 3-25: 8550 Rear Manifold

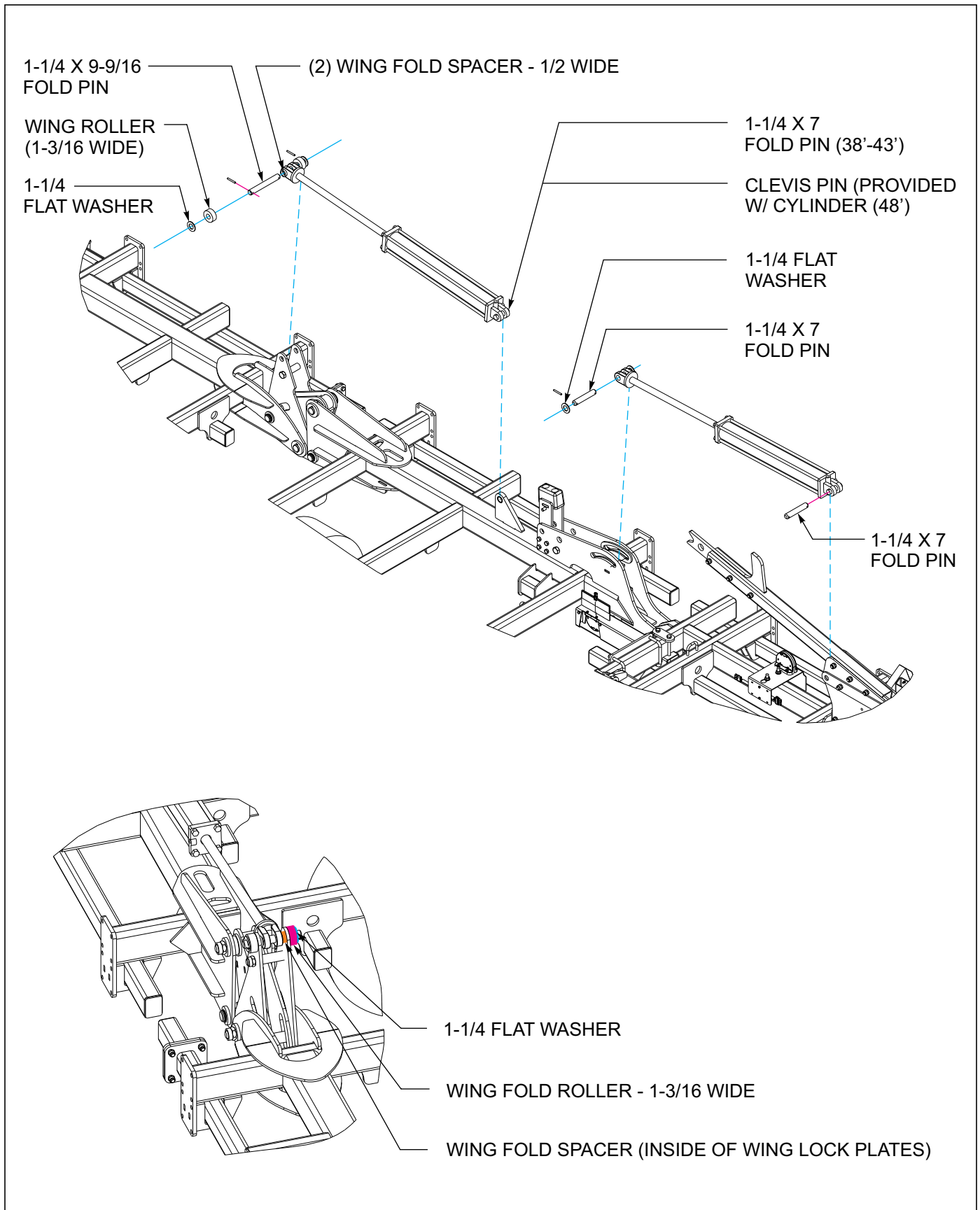
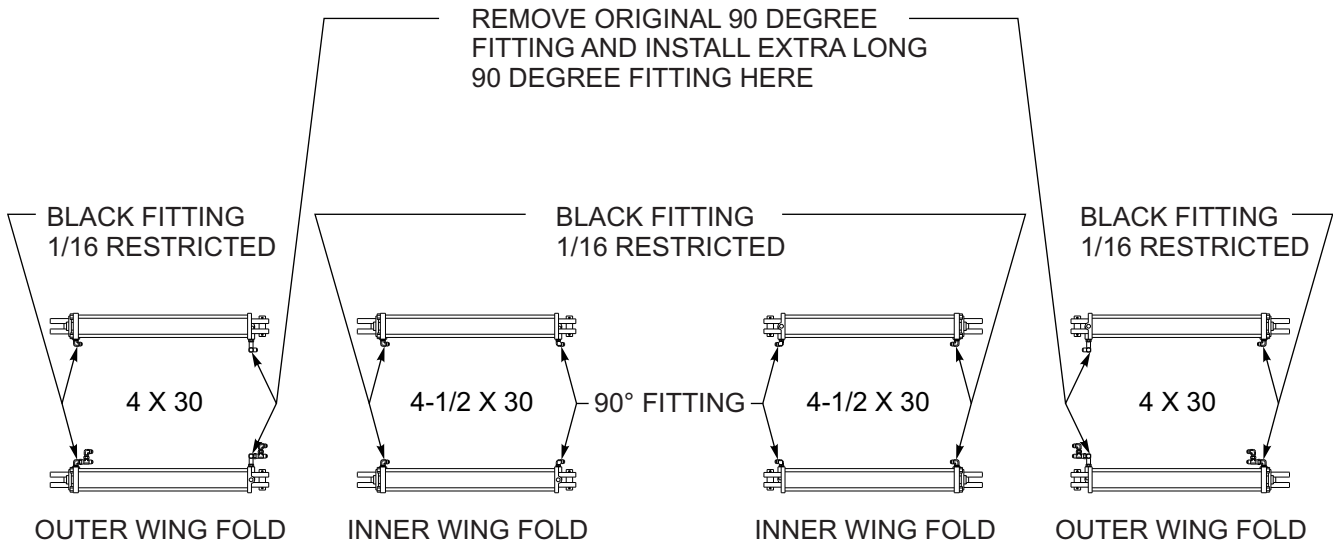

Figure 3-26: Fold Hydraulic Assembly

NOTE: ALL CYLINDERS HAVE FITTINGS ORIENTATED TOWARDS THE INSIDE OF THE MACHINE



FRONT

OUTER WING FOLD

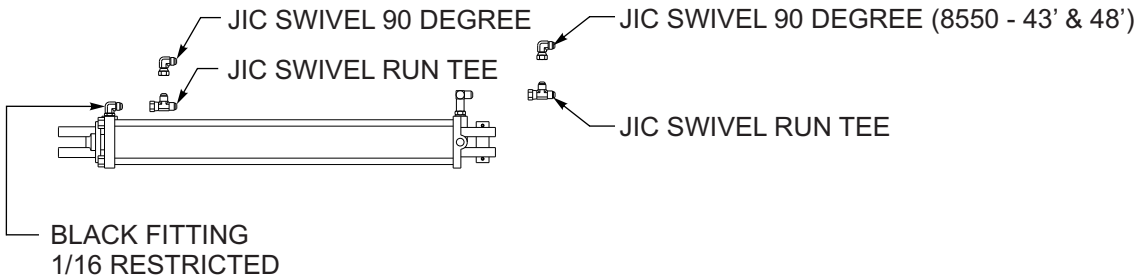

OUTER WING FOLD CYLINDERS ON FRONT ONLY ASSEMBLED LIKE THIS

Figure 3-27: Hydraulic Fitting Installation

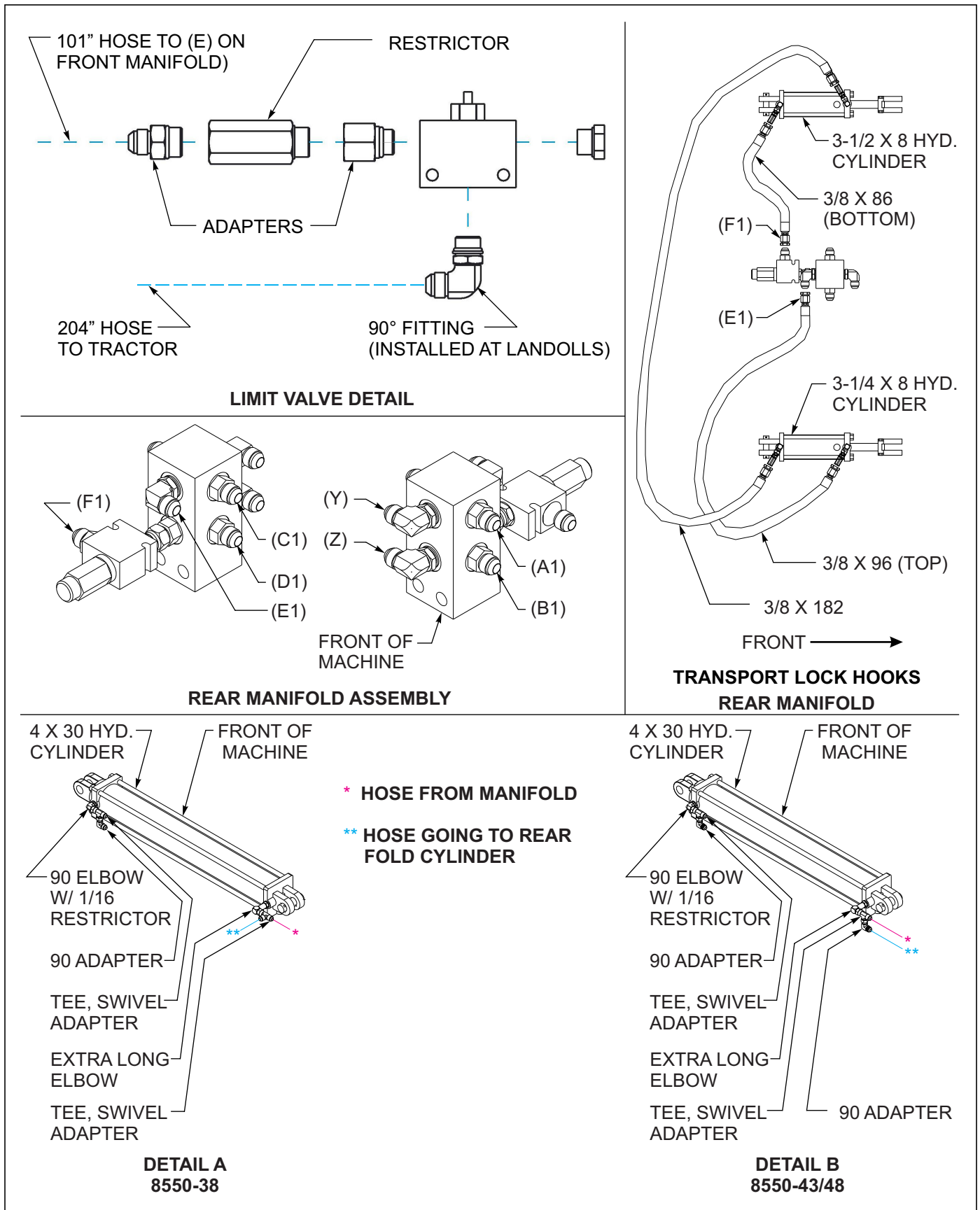

Figure 3-28: Transport Lock & Fold Hydraulic Assembly Details

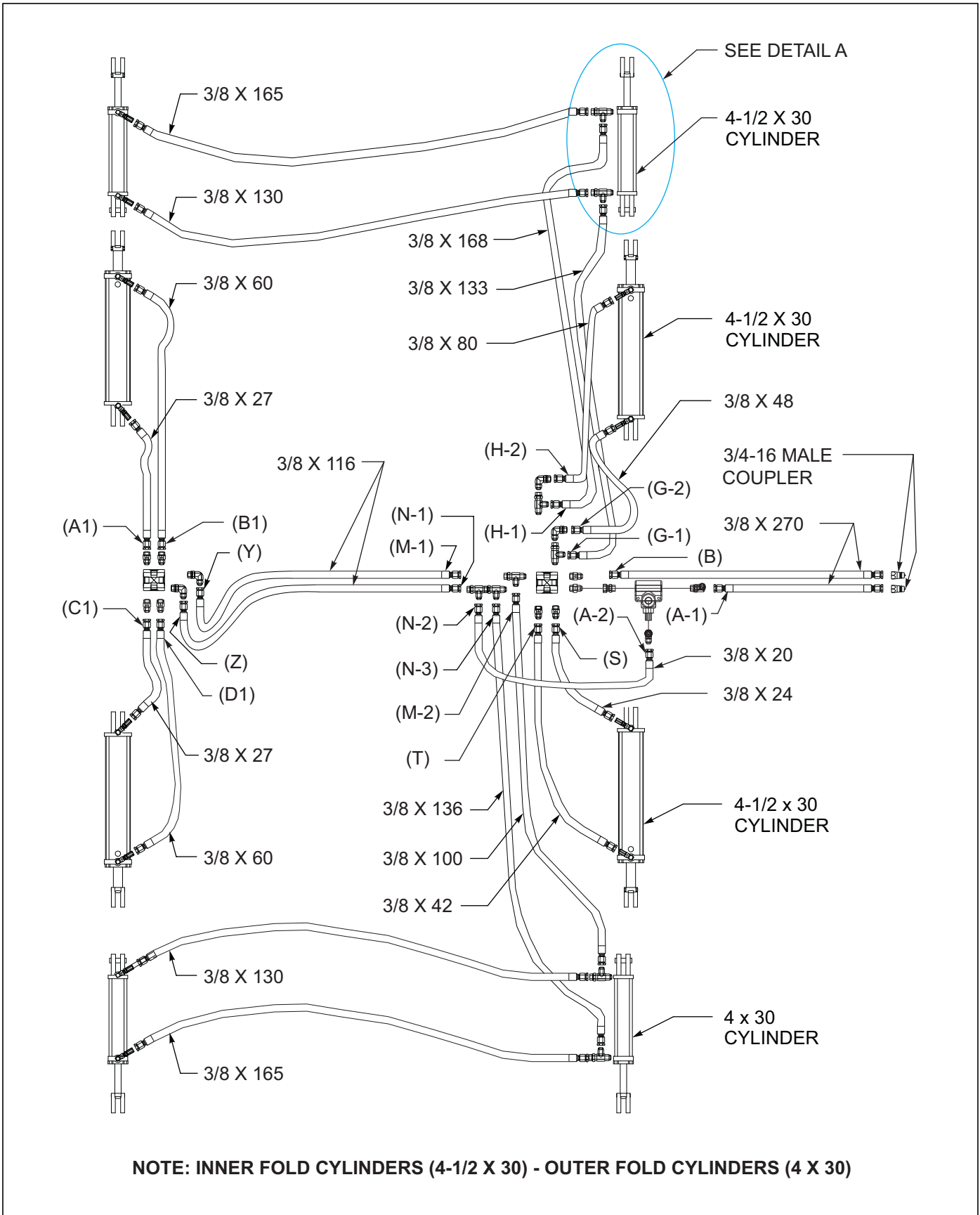
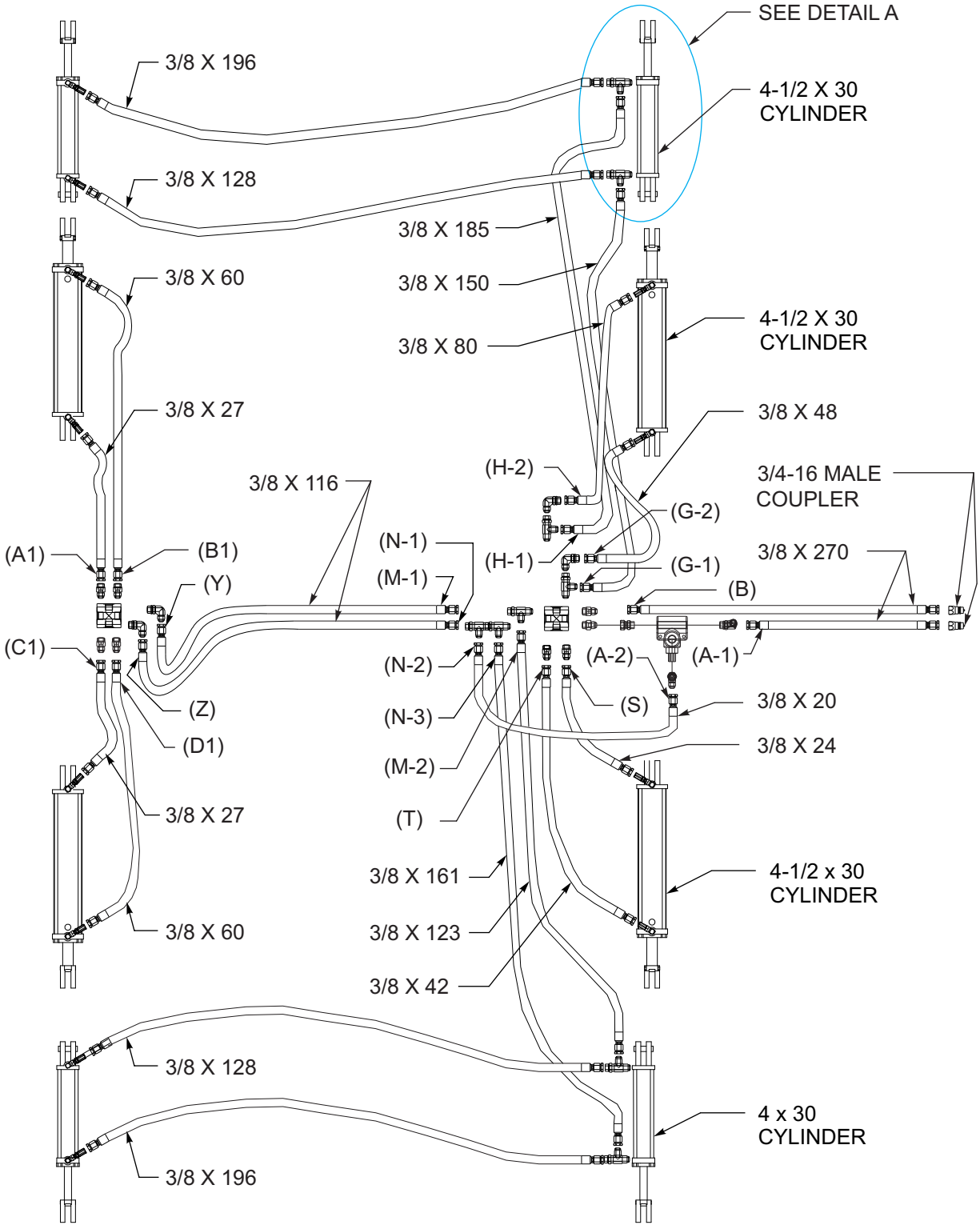

Figure 3-29: Fold Hydraulic Installation - 38'



NOTE: INNER FOLD CYLINDERS (4-1/2 X 30) - OUTER FOLD CYLINDERS (4 X 30)

Figure 3-30: Fold Hydraulic Installation - 43'

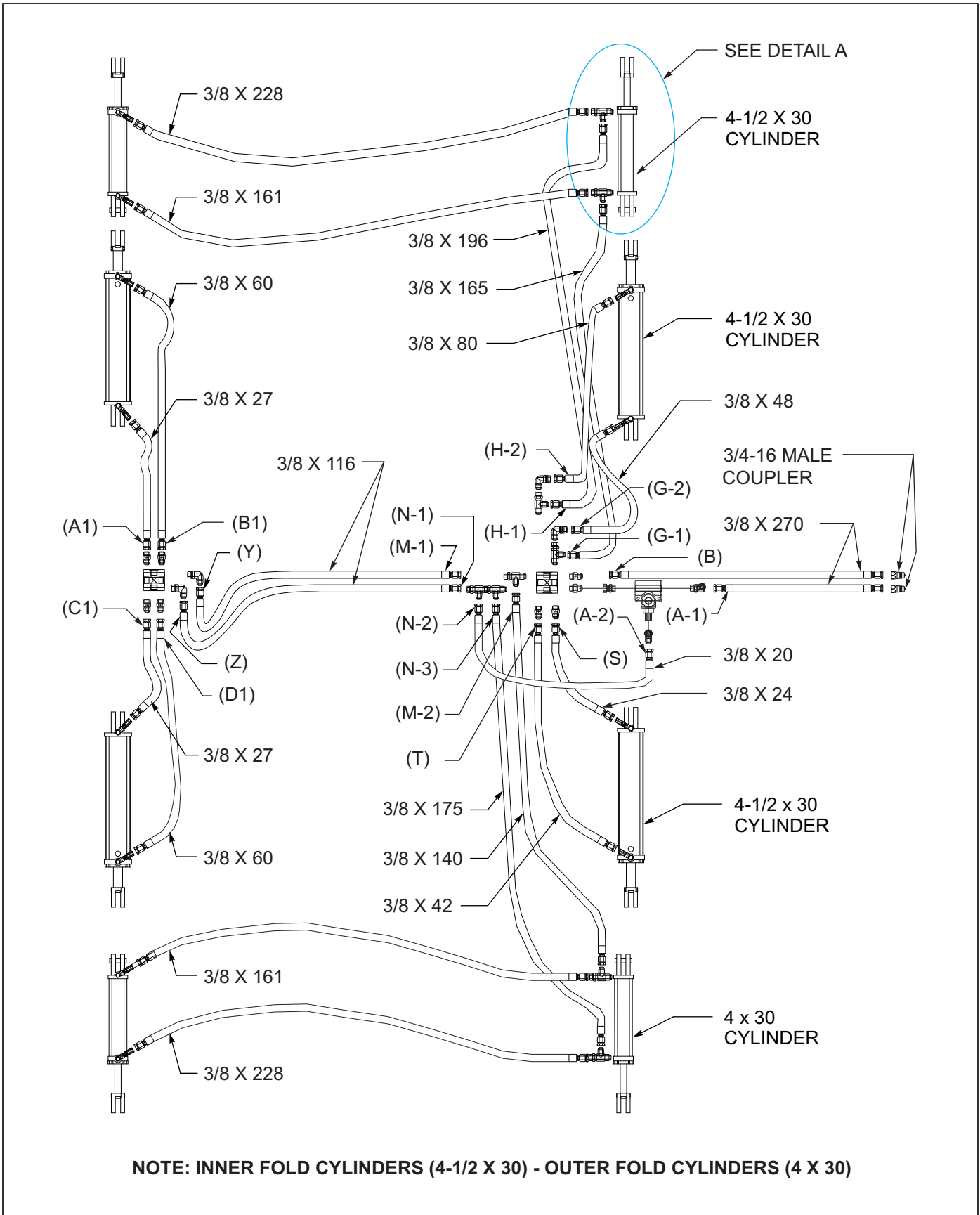

Figure 3-31: Fold Hydraulic Installation - 48'

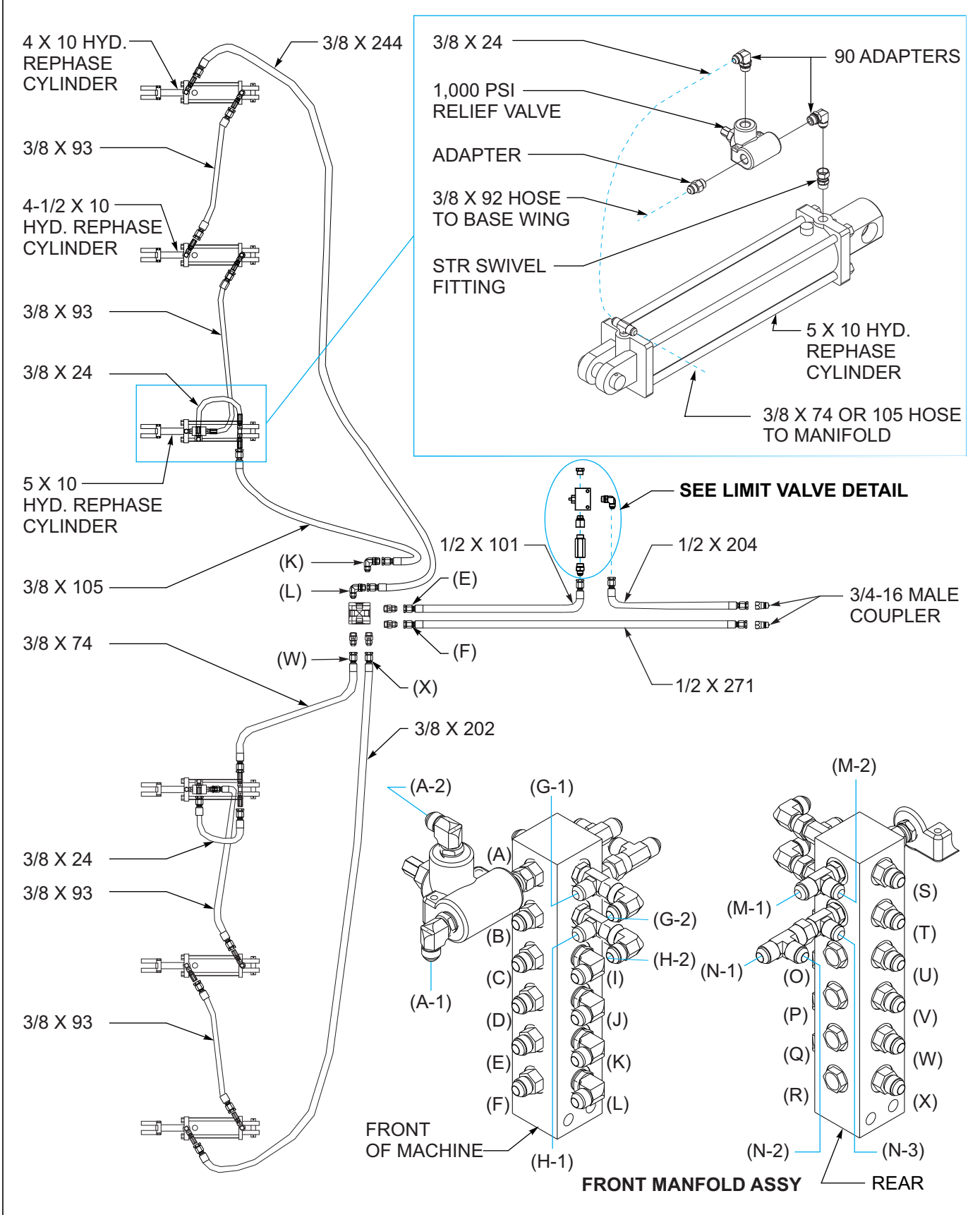

Figure 3-32: Hydraulic Lift Installation - 38'

ASSEMBLY INSTRUCTIONS

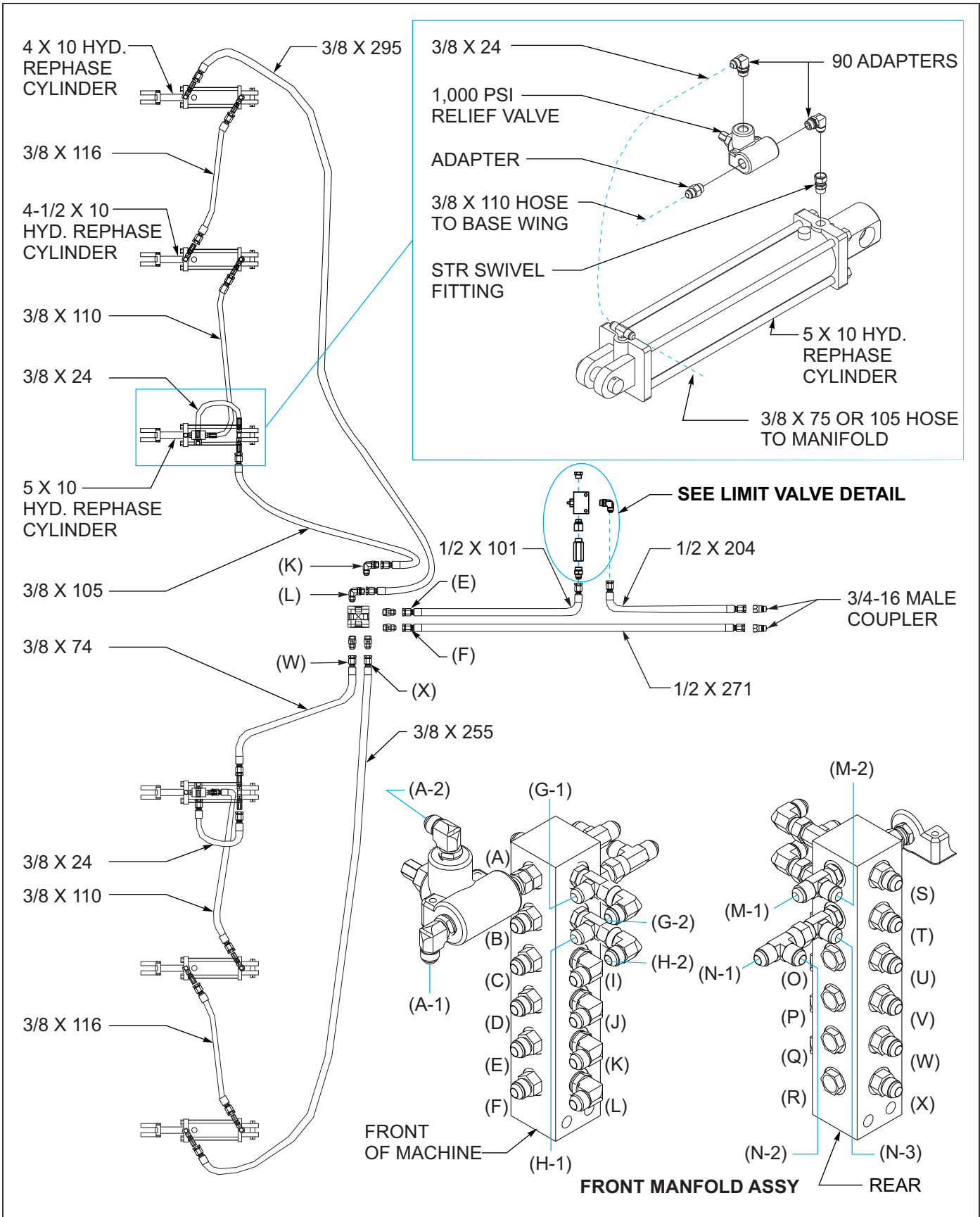

Figure 3-33: Hydraulic Lift Installation - 43'

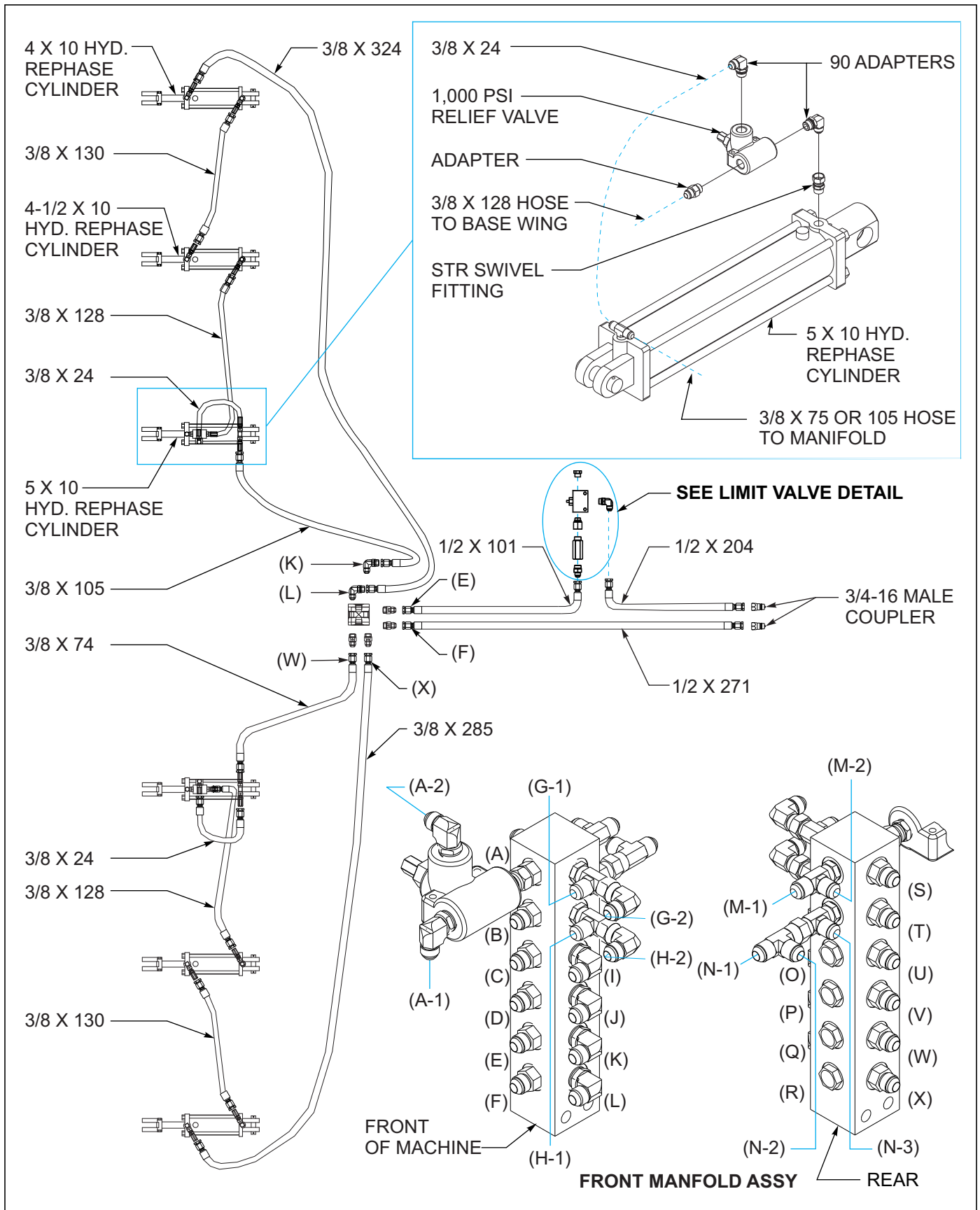

Figure 3-34: Hydraulic Lift Installation - 48'

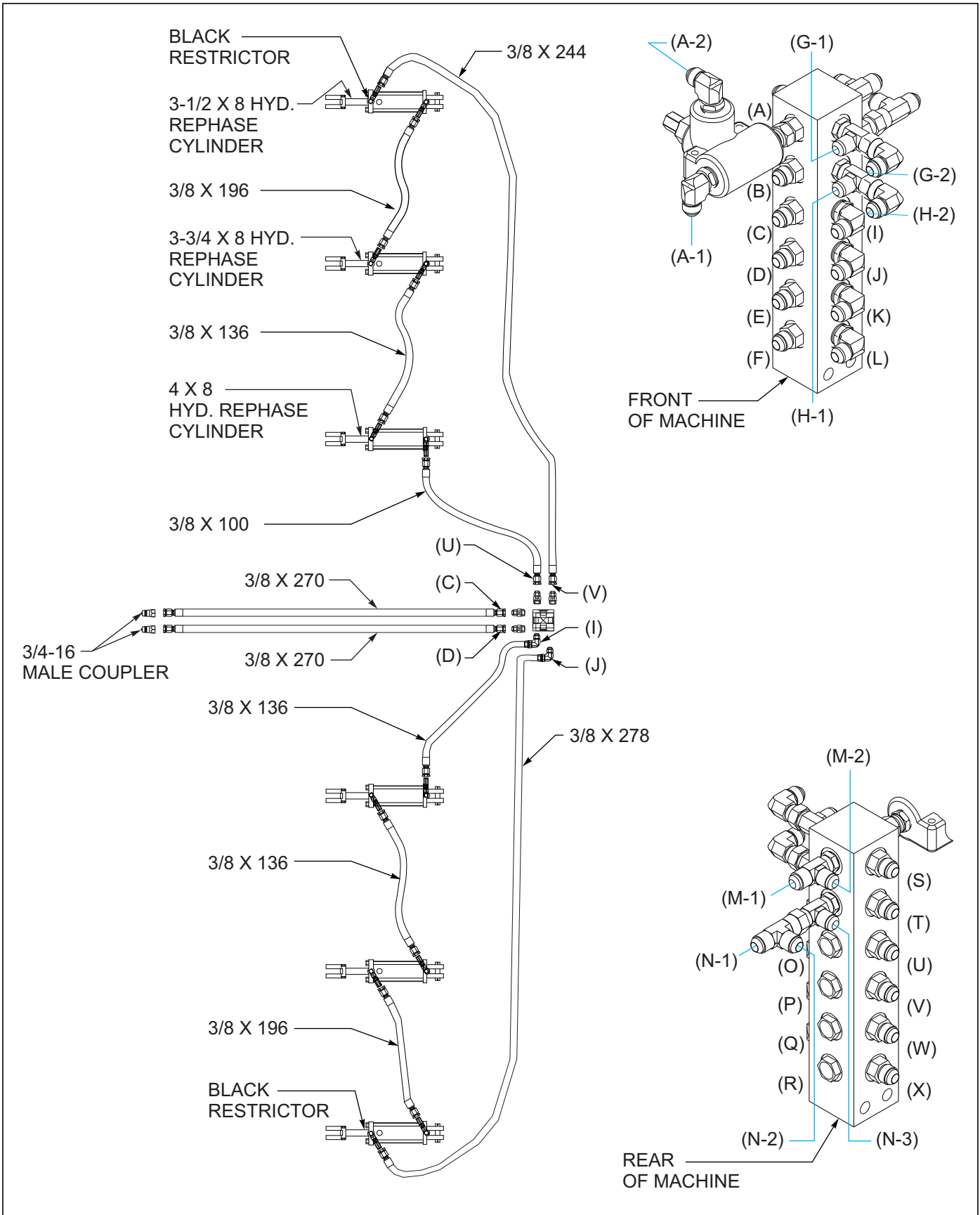

Figure 3-35: Hydraulic Gangs Installation - 38'

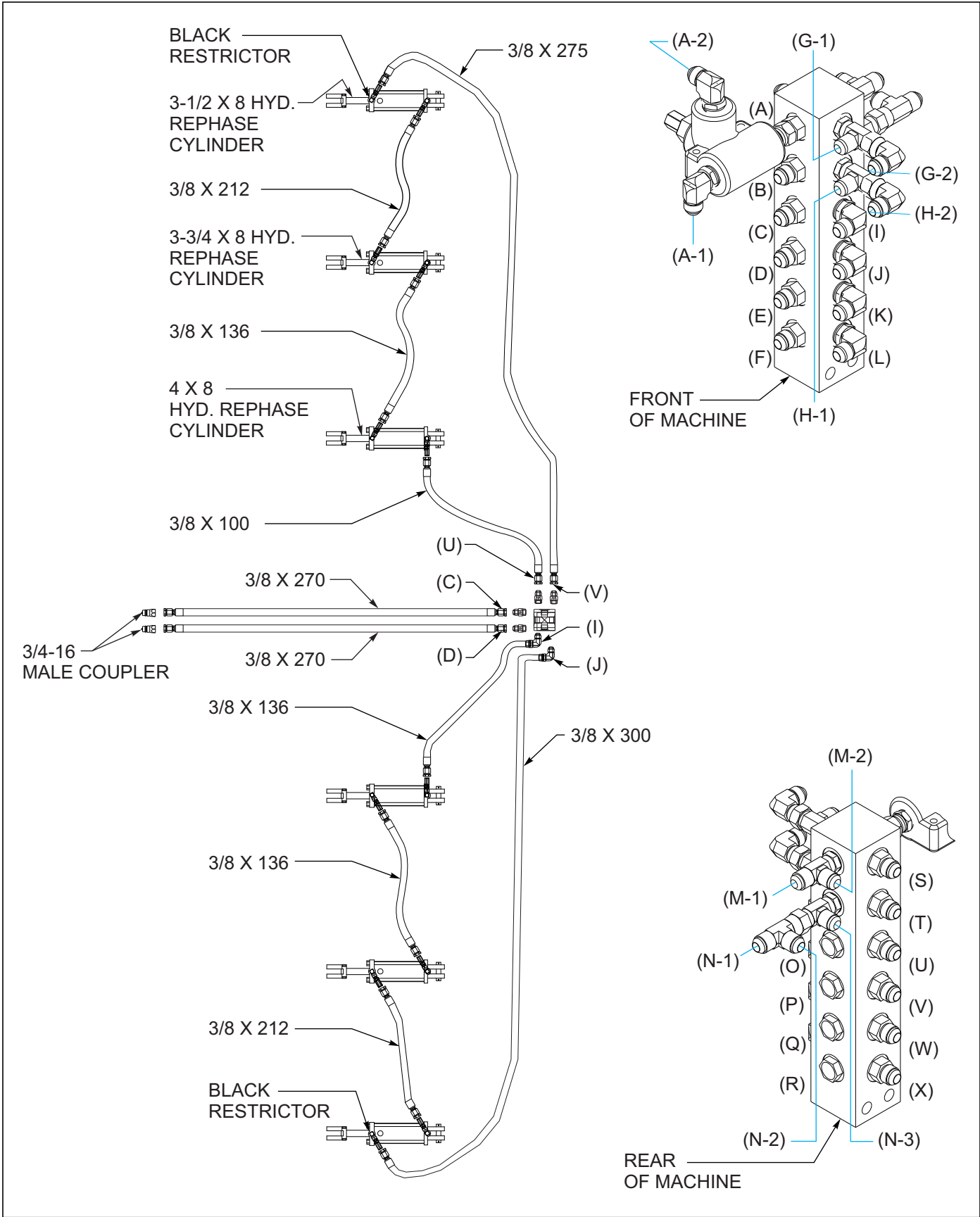

Figure 3-36: Hydraulic Gangs Installation - 43'

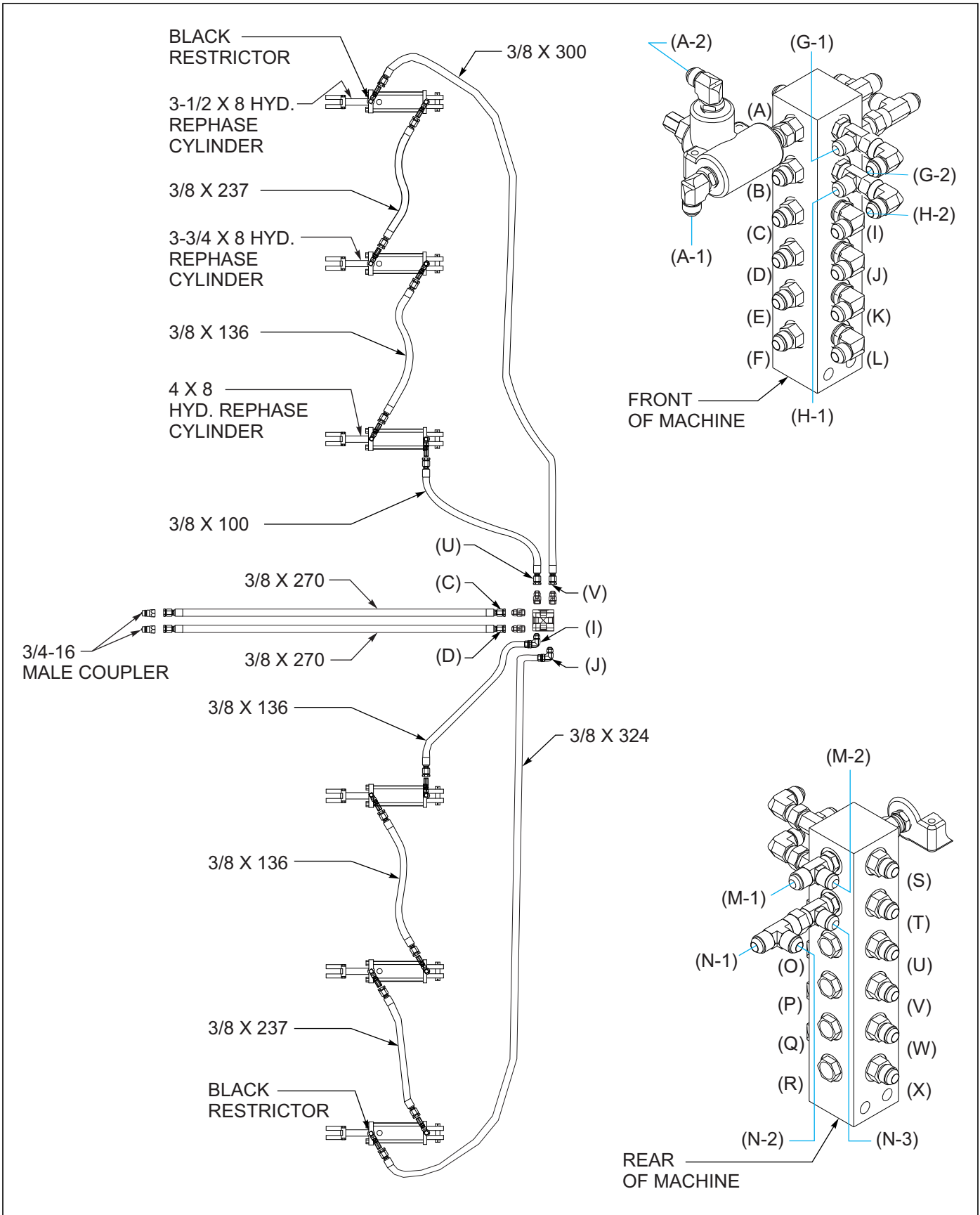

Figure 3-37: Hydraulic Gangs Installation - 48'

Shank Installation

See Figures 3-38 - 3-39 for shank placement dimensions. Verify that all shank clamps are properly installed.

1. Install or reposition any shanks and extensions that may have been turned around for shipping.
2. Install shanks in clamps See Figures 3-39.
 - a. Spring clamp assembly - Install shank in clamp using 5/8-11 X 1-3/4 round head square neck screw and flange lock nut provided.
 - b. Install shank clamp, 1/2-13 x 3-1/4 hex head cap screw, and hex lock nut across bottom of shank clamp weldment.
 - c. S-tine clamp assembly - Install shank in S-tine spring using 5/8-11 X 2-1/4 hex head cap screw and hex lock nut provided.
3. Install sweep on shank with 7/16-14 X 1-1/2 plow bolt, washers, and nuts provided. Note that the flat washer is only used in the lower slotted sweep hole.

NOTE

Verify that springs have been set to the proper tension. Adjust the spring until there is 1/8" gap between the top of the mount and locking jam nut on top of the spring See Figures 3-38. Lock the jam nut against the top of the spring, not the top of the mount. Torque main pivot bolt to 140 FT-LBS.

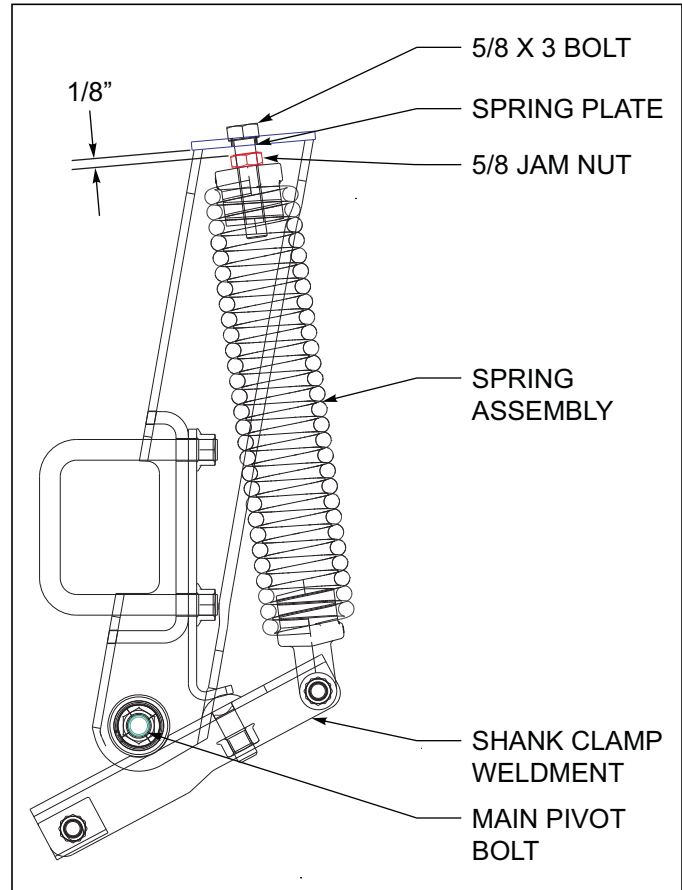

Figure 3-38: Spring Adjustment

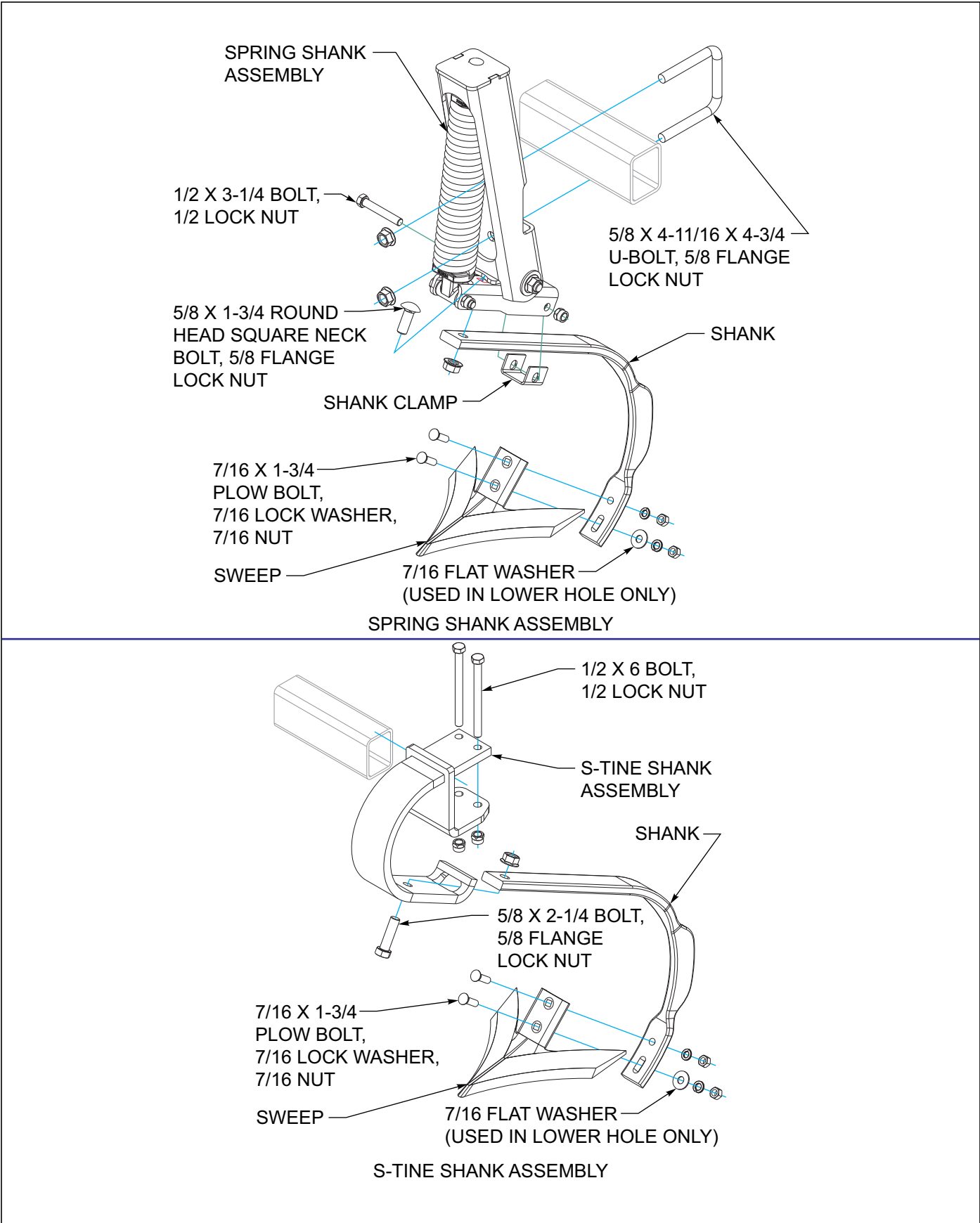

Figure 3-39: Shank and Clamp Installation

Final Assembly

1. Attach the Finisholl to a tractor sized for field operation and connect the lift cylinder hoses. Charge the lift system with hydraulic oil **(See Figure 3-32.)**
2. Connect the fold system hoses to the tractor and charge the fold cylinders **(See Figures 3-29 through 3-32.)** When fold cylinders have been charged with oil, connect the rod end of the fold cylinders to the wing frames using (p/n164565)1-1/4 x 9-9/16" pins, (p/n 170291) 1-1/4 x 7 pins, flat washers and roll pins.
3. For the hydraulic gang adjustment – connect the gang cylinders hoses to the tractor and charge the cylinders with oil **(See Figures 3-35 through 3-37.)** Watch the disc gangs carefully when initially charging with oil to make sure the gang do not bottom out on the frame when cycling.
4. Install the appropriate harrow(s) as described in **(Chapter 2, Figures 2-1 through 2-60.)**
5. Inflate all tires to proper inflation pressure as seen in **(Chapter 2, Page 2-1.)**
6. Grease the unit at all points listed in **(Chapter 4, See Figure 4-19 and Table 4-1.)**
7. Level the Finisholl wings to the center frame and from front-to-rear as described in **(Chapter 4, Page 4-8 and Page 4-9.)**
8. Level the disc gangs as described in **(Chapter 4, Page 4-10 and 4-11.)**

Table provided for general use. Adjust disc scrapers as described in **(Chapter 4, Page 4-11.)**

Operation and Maintenance



DANGER

Never allow anyone to ride on the 8550 Finisholl at any time. Allowing a person to ride on the machine can inflict serious personal injury or death to that person.



DANGER

Disc blades are extremely sharp. Exercise extreme care when working on or near disc blades. Do not allow discs to roll over or fall onto any bodily part. Do not allow wrenches to slip when working near disc blades. Never push wrenches toward disc blades. Do not climb over machine above disc blades. Failure to stay clear of disc blade edges can cause serious personal injury or death.



WARNING

All hydraulically elevated equipment must have cylinder lockouts installed or be lowered to the ground, when servicing or when equipment is idle. Failure to take preventive measures against accidental lowering can result in serious personal injury.



DANGER

Always lock the tractor drawbar in the center position when transporting the unit. Failure to do so can result in serious injury or death and cause damage to the equipment.



DANGER

When transporting the unit, place cylinder lockouts in the transport lock position after fully extending the cylinders. Insert the lockout pins to secure the cylinder lockouts. Failure to lockout the cylinders can cause the unit to settle during transport, which can result in serious injury or death and cause damage to the equipment.



CAUTION

When transporting farm implements on public roads, it is the responsibility of the operator to abide by state and local laws concerning wide loads, speed, safety emblems and safety lighting equipment. Drive at safe speeds. Particularly when rounding corners, crossing rough ground or driving on hillsides, to prevent tipping the tractor.

Tractor Preparation

The Landoll 8550 Finisholl is designed to be pulled by tractor equipped with a double lip or clevis type hitch. If your tractor is not equipped as such, you need to purchase the hitch from your local tractor dealer. Before attaching the Finisholl, prepare the tractor as follows:

1. Inflate the rear tractor tires equally and add ballast according to the tractor operator's manual.
2. Lock the tractor drawbar in the center position.

Attaching to the Tractor

1. Align the tractor drawbar with the machine. Raise or lower the Finisholl hitch, as needed, using the swivel jack. Carefully back the tractor to align the hitch clevis hole.



DANGER

Hitching - Crushing Hazard



You may be severely injured or killed by being crushed between the tractor and implement. do not stand or place any part of your body between machines being hitched. Stop tractor engine and set park brake before installing hitch pins.

2. Attach the unit with proper size hitch pin. Secure the hitch pin with locking retainer to prevent unintentional unhitching.
3. Always place the swivel jack in the field storage position before setting the machine in motion. (mount is inside of hitch.)
4. Attach safety chain to tractor allowing plenty of movement for turning both directions. The safety chain should latch securely to prevent it coming loose.
5. Clean all hydraulic couplings and attach to the tractor.
6. Fully extend the hydraulic lift wheel cylinders, and place the cylinder lockouts in the transport lock position over the cylinder rods. Fold implement wings and install lock pins to secure the wings.
7. Plug in the electrical 7-pin connector for the lights.
 - a. The tractor should have a good clean receptacle, free of dirt and corrosion.
 - b. Make sure the 7-pin connector is inserted all the way in, and allows the cover to latch over the keyway to secure it in place.

NOTE

The lighting system requires a good clean connection. If the lights do not seem to work right, check the installation of the 7-pin connector and the condition of the pins.

Hydraulic Lift System

The Finisholl is equipped with a rephasing hydraulic lift system to raise and lower the unit in the field.



WARNING

Escaping hydraulic fluid can cause serious personnel injury. Relieve system pressure before repairing, adjusting, or disconnecting. Wear proper hand and eye protection when searching for leaks. Use cardboard instead of hands (See Figure 4-1.) Keep all components (cylinders, hoses, fittings, etc.) in good repair.

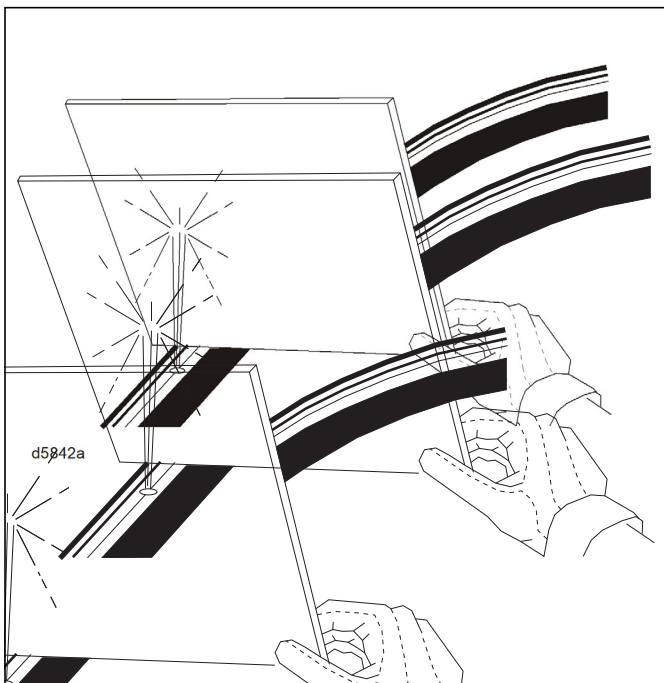

Figure 4-1: Hydraulic Leak Detection

1. The rephasing hydraulic lift system contains smaller wing frame cylinders plumbed in series with larger center frame cylinders. It is important that the cylinders be connected in the proper series for the lift system to operate correctly. When the cylinders are fully extended and held in this position, oil is able to flow through the cylinders (or rephase) and allow the cylinders to operate in sync. This also allows the system to purge any air that may enter the system without having to loosen or crack hydraulic lines.

IMPORTANT

The hydraulic system is not filled with oil and should be purged of air before transporting and field operations.

2. Carefully hitch the Finisholl to the tractor and connect the hydraulic lift hoses. Check to make sure the tractor hydraulic reservoir is full of the manufacturer's recommended oil.
3. Slowly raise the machine, and continue to hold the hydraulic lever until all lift cylinders are fully extended.
4. With all cylinders fully extended, remove the transport locks (See Figure 4-2.) Lower and raise the unit to verify that all cylinders are working simultaneously throughout the stroke.

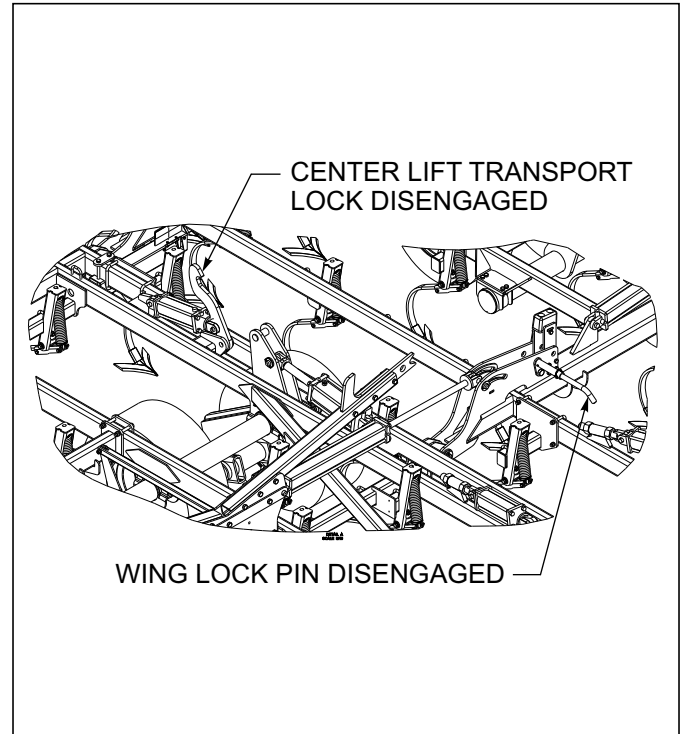

Figure 4-2: Stored Transport Lock Locations

5. If the cylinders are not working evenly or together, fully extend the lift cylinders and continue to hold the lever to purge any remaining air. Do not loosen any hoses or fittings. Recheck tractor reservoir to make sure it is within operating limits.
6. Always fully extend the lift cylinders and hold the lever to ensure the cylinders are rephased before starting any field operation. This will keep all cylinders in time and frame sections level when operating.

NOTE

If performing service or repair work, lower the machine to the ground and relieve hydraulic pressure. If a hydraulic component is disconnected, repaired, or replaced, it will be necessary to purge the system of air before operation.

Hydraulic Fold System

The Finisholl is equipped with a hydraulic fold system to raise and lower the wing frames for narrow transport.



WARNING

Escaping hydraulic fluid can cause serious personal injury. Relieve system pressure before repairing, adjusting, or disconnecting. Wear proper hand and eye protection when searching for leaks. Use cardboard instead of hands (See Figure 4-3.) Keep all components (cylinders, hoses, fittings, etc.) in good repair.

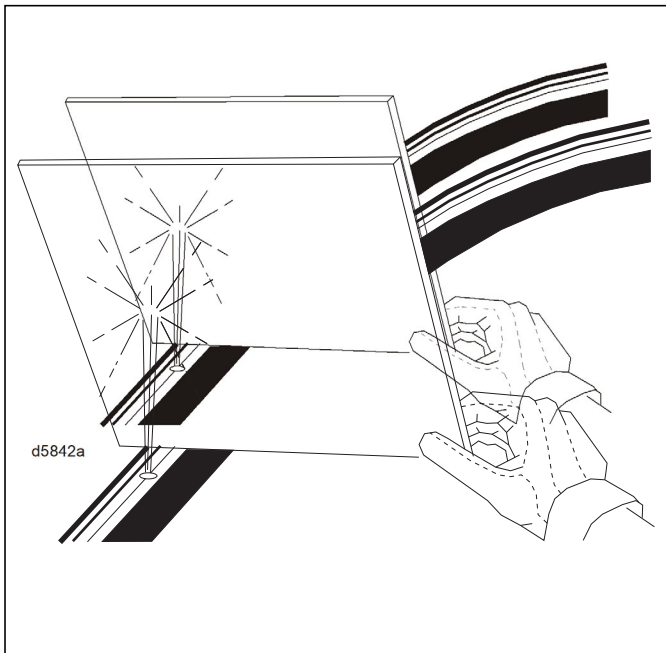

Figure 4-3: Hydraulic Leak Detection

1. Be sure the fold system is fully charged with hydraulic oil before attempting to fold/unfold the unit. Air in the system can allow uncontrolled dropping of the wing frames causing serious personal injury or machine damage. The system needs to be charged with oil initially and any time the system opened for repair such as cylinder, hose, or fitting replacement/repair.
2. To charge the system, unpin the end(s) of the fold cylinders, and position them so they can extend and retract without contacting any frames or other parts.
 - a. Check the tractor hydraulic fluid level to make sure it is full of the manufacturer's recommended hydraulic fluid. Connect the hydraulic fold and lift hoses to the tractor.
 - b. Fully extend the lift cylinders and raise the implement.
 - c. Extend and retract the fold cylinders several times. The fold cylinder rod travel should be smooth and positive when all air has been purged from the system. Due to large amounts of hydraulic oil required, recheck the tractor fluid level to make sure it is within proper operating limits.
 - d. Reconnect the fold cylinder pins to the wings.
3. The hydraulic fold system is equipped with restrictors in the cylinders to prevent uncontrolled falling of wing frames when folding/unfolding. Removal or improper assembly of these restrictors can cause the machine to fold improperly and result in serious machine damage.
4. To fold/unfold the Finisholl, find a level area large enough to accommodate the machine when it is fully unfolded. The tractor should be stopped and not moving with the implement fully raised. Remove the wing transport lock pins from the mounts and install them in the storage locations.

Folding the 8550 Finisholl

1. Fully raise machine.
2. Begin folding the machine. Transport locks will engage on the center lift as the outer wings are folding, fully fold all inner and outer wings (See Figures 4-4 and 4-5.)
3. Take note that both center lift transport locks are engaged. Lower machine to locks and continue to hold lever, this will allow the inner and outer wing transport wheels to retract, reducing the transport width.
4. When the unit is fully folded, remove clip pin and slide wing lock pins rearward to engage wing lift transport locks (See Figure 4-5.)

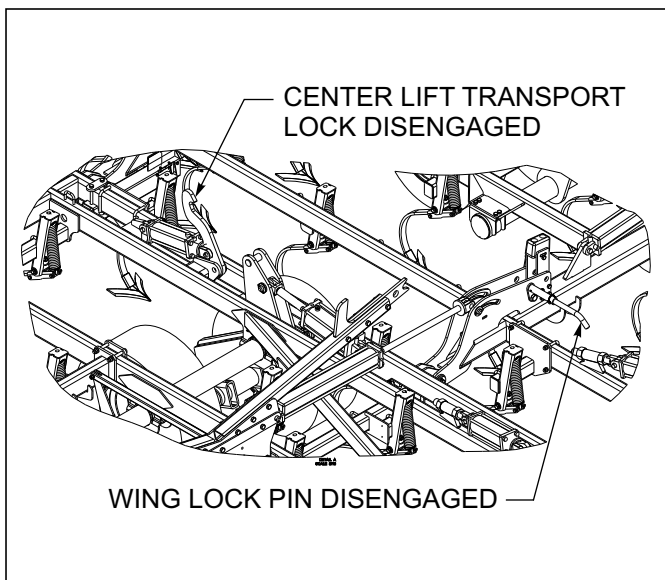

Figure 4-4: Stored Transport Locks

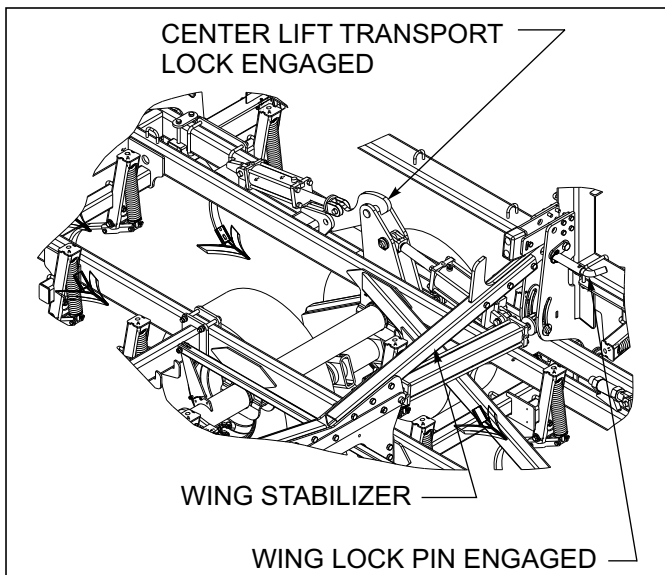

Figure 4-5: Installed Transport Locks

Unfolding the 8550 Finisholl

1. Disengage wing transport locks.

IMPORTANT

Failure to remove the lock pins when unfolding will result in serious damage to the implement. Be sure other people and pets are a safe distance away.

2. Fully raise the folded machine to unhook the locks and continue to hold the lever to fully extend the wing transport wheels (See Figures 4-4 and 4-5.)
3. Unfold the machine. Transport locks will disengage from the center lifts during the unfolding process.
4. Continue to hold lever until the fold cylinders are fully extended to lock the outer wing fold plates (See Figure 4-6.) This will allow the wings to fully flex in the field.

NOTE

If the operator chooses to leave the wing transport wheels extended while transporting the Finisholl, some settling of the machine may occur and it may be necessary to raise the machine to disengage the center lift transport locks.

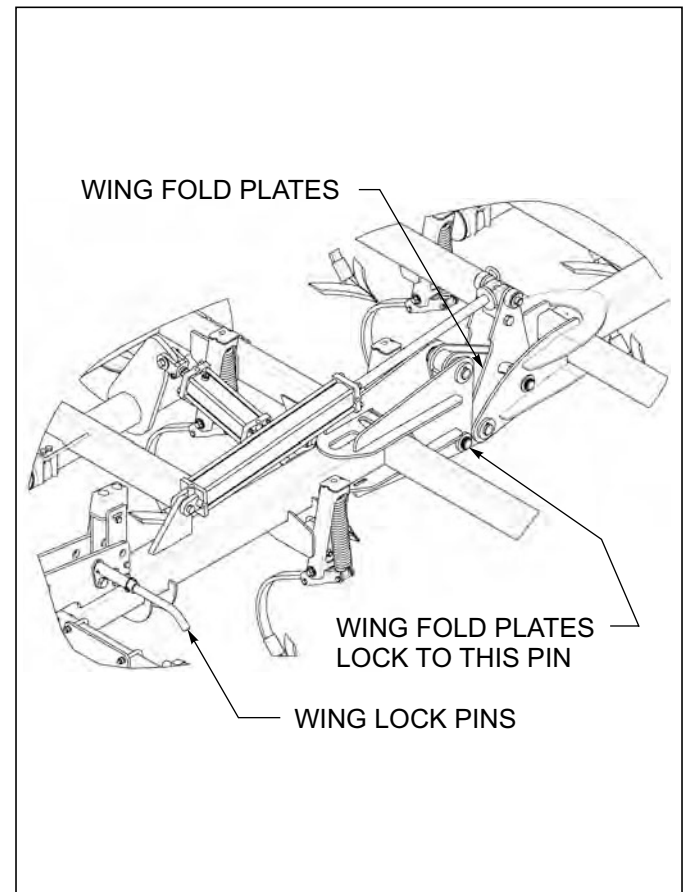

Figure 4-6: Wing Fold Plates

Transporting

1. Check and follow all federal, state, and local requirements before transporting the Finisholl.
2. The Finisholl should be transported only by tractor required for field operation. The implement weight should not exceed more than 1.5 times the tractor weight. Unless noted on the implement, maximum transport speed is 20 mph for the implement and is designated on the speed identification symbol (SIS) located on the front of the implement (**See Figure 4-7.**)



WARNING

Excessive speed may result in the loss of control of the tractor and implement, reduced braking, or failure of the implement tires or structure. Do not exceed the implement maximum specified ground speed regardless of the capability of the maximum tractor speed.

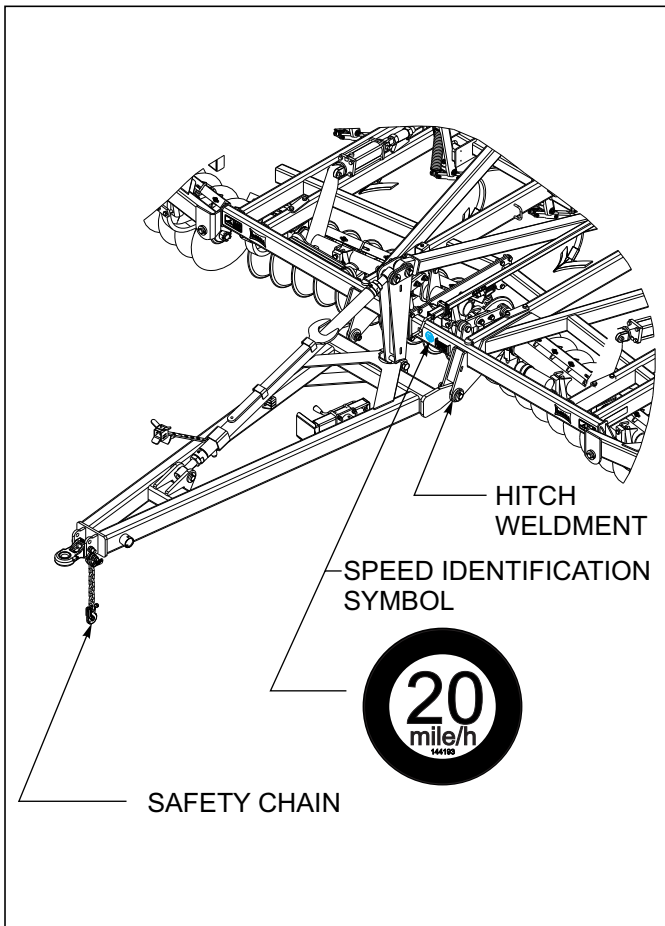

Figure 4-7: Hitch, Speed Identification Symbol, and Safety Chain

3. When towing in combination, the maximum equipment ground speed shall be limited to the lowest specified ground speed of any of the towed implement(s).
4. Maximum transport speed shall be the lesser of the specified in the operator's manual, speed identification symbol (SIS), information sign of the towed implement, or limit of road condition.
5. Slow down when driving on rough roads. Reduce speed when turning, or on curves and slopes to avoid tipping. Equipment altered other than the place of manufacture may reduce the maximum transport speed. Additional weights, added tanks, markers, harrow attachments, etc. may reduce the implements carrying capabilities.
6. A safety chain is provided with the implement to insure safe transport.
7. The safety chain should have a tensile strength equal to or greater than the gross weight of the implement. The chain is attached to the lower hitch clevis hole with two flat washers between the clamp plates to assure a tight connection. Always use a 1" diameter Grade 8 bolt for this connection.
8. Attach the safety chain to the tractor drawbar (**See Figure 4-8.**) Refer to the tractor operating manual for additional information. Provide only enough slack in the chain for turning. Do not use an intermediate chain support as the attaching point for the chain on the tractor. Do not pull the implement by the safety chain.

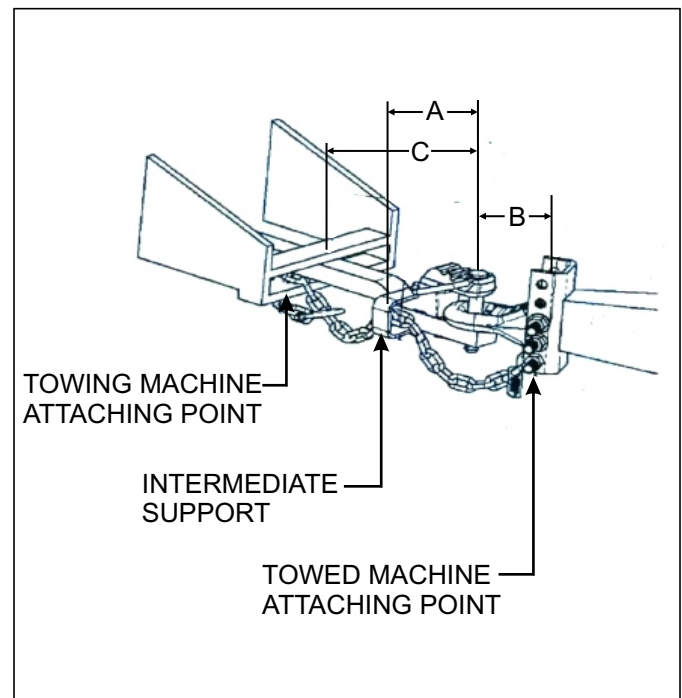

Figure 4-8: Auxiliary Attaching System with Intermediate Support

9. When unhitching from the tractor attach the hook end of the chain to a free link close to the hitch clevis for storage. This will keep the hook off the ground, reducing corrosion and keep the hook functioning properly.
10. Regularly inspect the safety chain for worn, stretched, or broken links and ends. Replace the safety chain if it is damaged or deformed in any way.
11. Check that tires are of proper size, load rating, and inflated to manufacture specifications before transporting. Transporting equipment on under inflated tires and faster than rated speeds will damage the implement tires. Check wheel lug bolts to insure tightness.
12. Know the transport heights and widths of the unit before transporting. Attachments such as leveling harrows can increase the transport dimensions of the implement. Use caution when transporting near bridges and power lines.

 WARNING
Electrocution can occur without direct contact.

13. Raise the unit to full transport height, and fold the implement wing sections.
14. Install transport locks and pins on both lift and fold systems. Do not depend solely on implement hydraulics for transport **(See Figures 4-9 and 4-10.)**
15. Transport during daylight hours whenever possible. Always use flashing warning lights, except where such use is prohibited by law. Make sure lights, reflectors and SMV emblem are clearly visible and operating. Remove any obstructions such as dirt, mud, stalks or residue that restricts view before transporting.

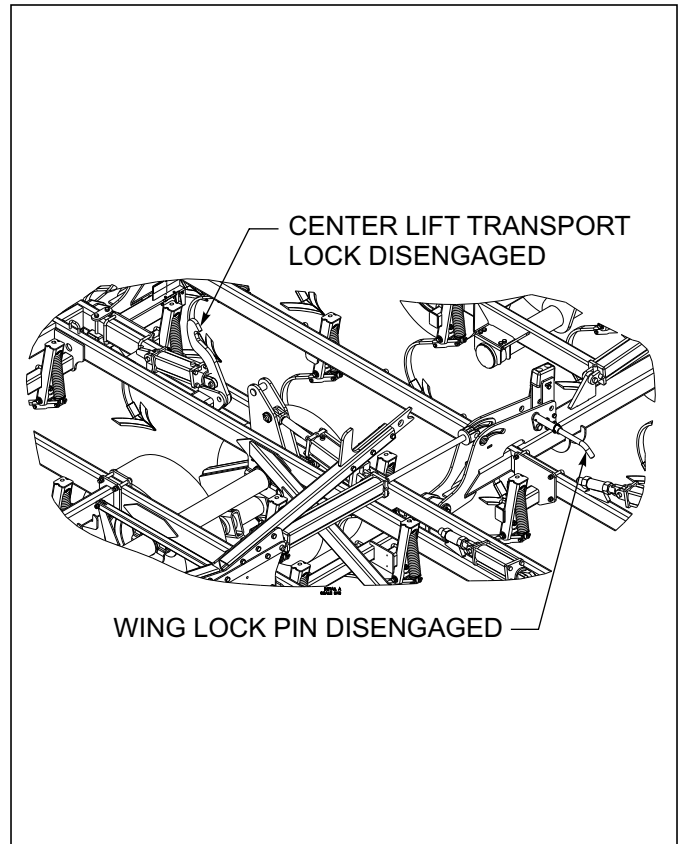

Figure 4-9: Stored Transport Locks

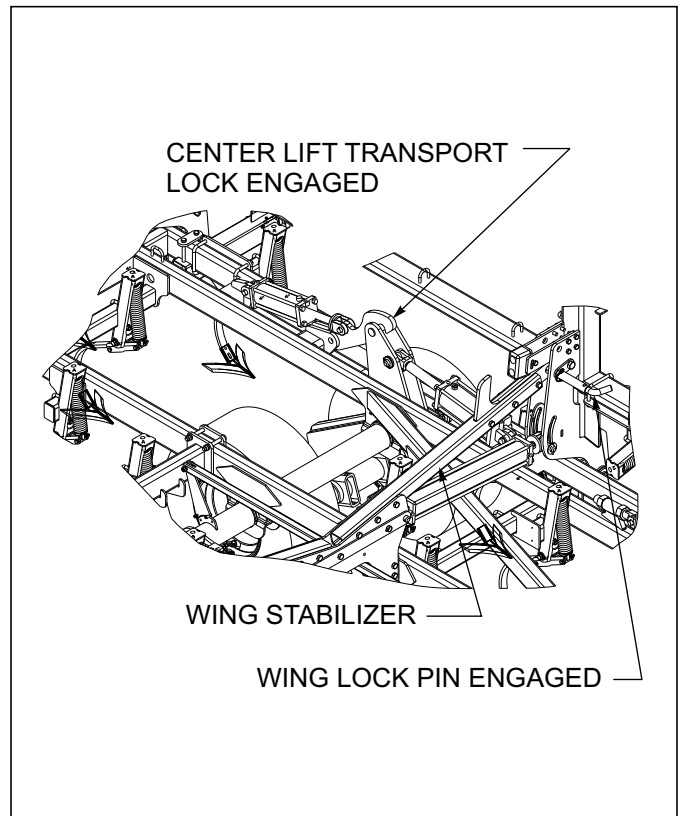

Figure 4-10: Installed Transport Locks

LED Light Operation

1. Attach the seven-pin plug to the socket at the rear of the tractor. The socket must be in good working order, and free of dirt, grease, and corrosion. The connection must be clean with good contact for the LED light to function properly. Fully insert the plug into the connector and make sure the latch securely hooks the plug.
2. Allow enough cable above the hitch to allow for turning. Secure or tie up any excess cable to prevent it from catching on the hitch or stalks.
3. Verify proper light function before transporting. Replace or repair any component that is damaged or not functioning. Make sure all lighting is clean and clearly visible. Follow local regulations regarding lighting & marking.

General Operation

1. The horsepower requirements are typically 8-10 PTO horsepower per foot of cut for the Finisholl. This will vary widely due to speed, depth, moisture, residue, and types of soils. Local dealers can help in making recommendations for your areas.
2. Operating speed is typically 6-8 mph. Excessive speed can cause the unit to bounce and create uneven working depths and ridging.
3. Lift wheels must always be in contact with the ground and carrying some implement weight. Never operate unit with the tires off the ground.
4. Avoid turning sharply with the Finisholl in the ground. This can put excessive side load on the disc gangs, shanks, harrow, and hitch. Always raise the Finisholl completely when making turns or backing to prevent shank damage. Reduce speed at field ends, and raise Finisholl before making turns.

Leveling (Side to Side)

1. Leveling the Finisholl side-to-side involves leveling the wing frames to the center frame. The unit should be level side-to-side when operating in the field.
2. To level the unit, verify that all tires are properly inflated. With the implement unfolded, raise the unit to fully extend the lift cylinders. Continue to hold the tractor lever 30-60 seconds to insure that the cylinders are fully extended and the rephasing lift system has been purged of air. Lower the implement until the sweeps are approximately 1" off the ground. On the center frame, lay a straight-edge across the top of the frame, and measure the distance from the top of the welded busing to the top side of the frame of the walking tandems (See Figure 4-11.)

3. Measure the wing frames from the top of the welded washer with the cross pin through it to the top of the frame. As a starting point, make this dimension the same as the center frame. Adjust the cylinder anchor at the base end of each wing frame lift cylinder to set the wing frame height. An adjusting wrench is provided on the center frame to make this adjustment. It may be necessary to lower the Finisholl to the ground and relieve weight on the lift cylinder anchors to make this adjustment. If required, fully raise the implement, lower to just above the ground (approximately 1"), and re-verify measurements. Repeat as necessary until the center and wing frame heights are the same. Securely tighten the lift cylinder anchor adjusting nuts when complete (See Figure 4-12.)

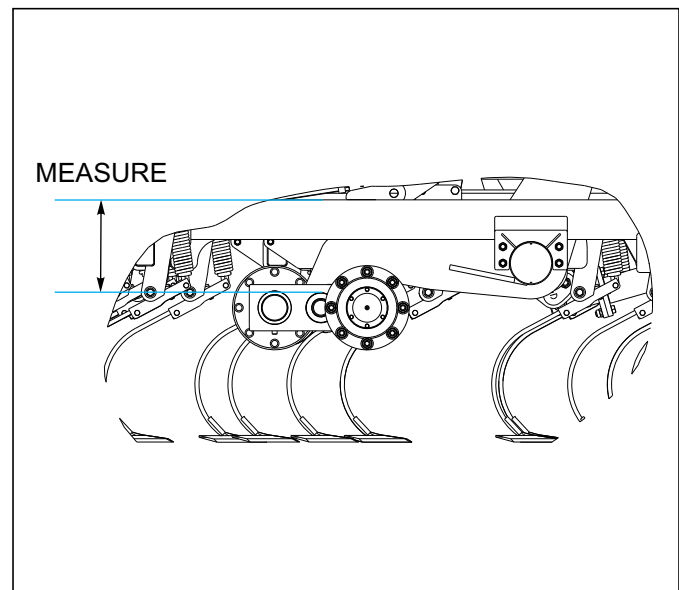

Figure 4-11: Measuring Center Frame

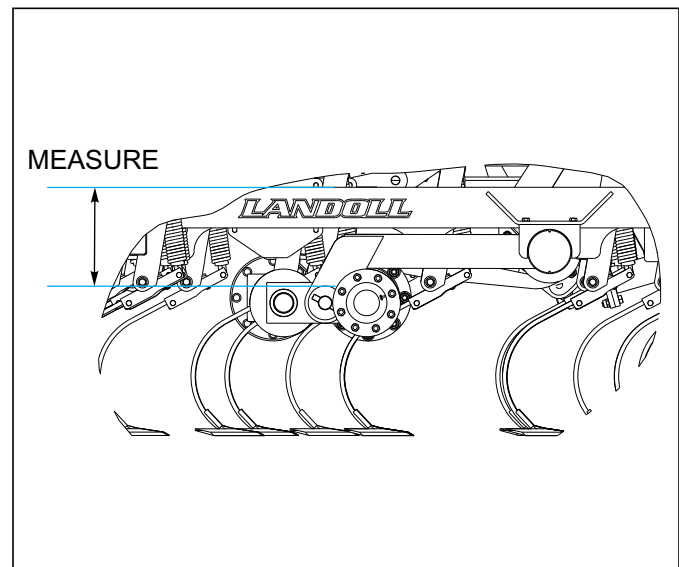

Figure 4-12: Leveling Wing Frame from Side to Side

Leveling (Front-to-Rear)

1. The Finisholl hitch is fully adjustable for height so the implement may be set to operate level from front-to-rear. This will insure the sweeps run level, and have an even working depth across the implement. Height may be adjusted for various tractor drawbar heights, operating depth, attachments, etc. To adjust the Finisholl hitch height, loosen the locking jam nuts on each end of the adjustable radius rod located above the hitch (See **Figure 4-13.**) Wrenches are stored on the center frame and radius rod to make this adjustment. Extend or retract the radius rod to obtain the desired hitch height.

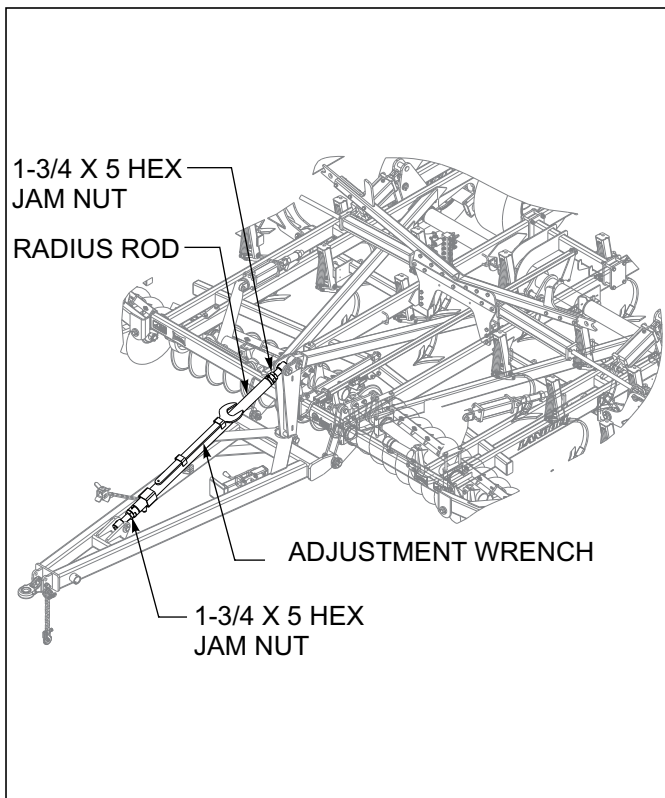

Figure 4-13: Radius Rod Adjustment

NOTE

It may be easier to adjust the radius rod when the unit is lowered to the ground to remove pressure from the radius rod. Retighten the locking jam nuts when finished.

2. Disc gang depth will also effect the front-to-rear level of the implement. Level the unit for the desired discing depth. Changes to discing depth will require the unit to be releveled front-to-rear.

Depth Stop Adjustment

The overall operating depth of the Finisholl is controlled by a single-point depth stop. The stop is located at the center front of the machine.

1. Adjust the depth stop by turning the handle in (clockwise) to increase operating depth (See **Figure 4-14.**) Turn the handle out (counter-clockwise) to decrease operating depth. One turn will equal approximately 3/16" adjustment in depth.
2. The gauge on the side of the depth stop tube gives a reference for depth setting. The "A" setting refers to maximum operating depth.

IMPORTANT

For maximum operating depth, the lift wheels must be in contact with the ground and carry some of the machine weight. Raising the lift wheels off the ground, permits uncontrolled depth of each frame section and does not allow the self-leveler to function properly.

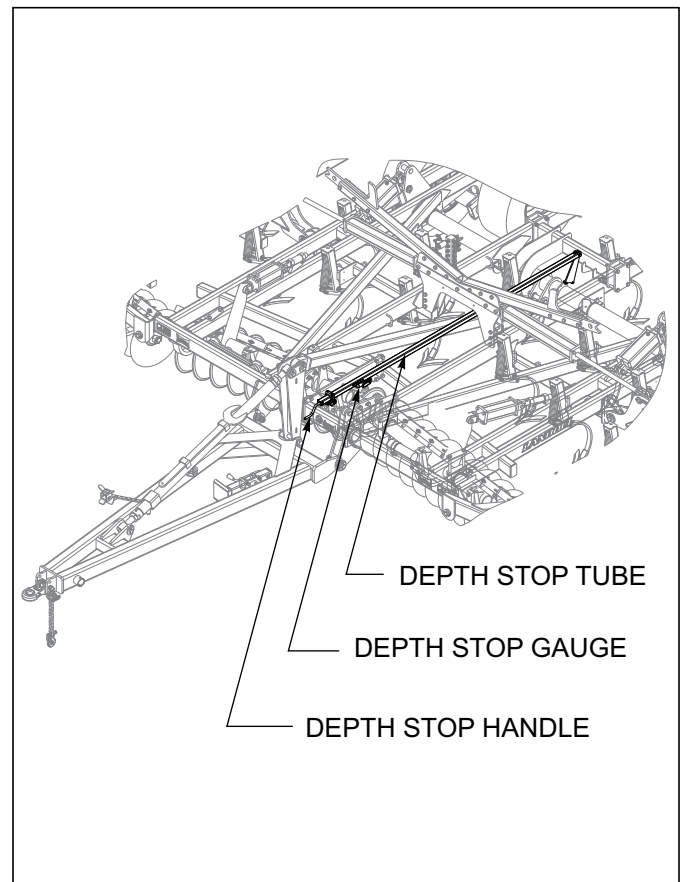

Figure 4-14: Depth Stop Adjustment

Disc Blades

1. The 8550 Finisholl is equipped with low concavity disc blades. This is 1.60" concavity for 22" diameter blades and 1.40" concavity for 20" diameter disc blades. The use of other concavity blades can give unpredictable results and is not recommended.
2. The 22" x 4 ga (.256") diameter blades may be either standard or rollable disc blades. When operating in rocky conditions, the standard (non-rollable) blades are recommended.
3. **Sharpening** – In some cases there is a desire to sharpen disc blades for improved cutting. There are several people who roll-sharpen disc blades. Most disc blades used today are made of chrome-boron steel. The chrome-boron steel has a higher hardness than traditional carbon-steel blades for increased wear and toughness. Higher hardness makes roll sharpening more difficult often with mixed results, and is not covered by warranty. Disc blade manufacturers will not cover any alterations to blades other than the place of manufacture. Results from roll-sharpening damage may not be immediate, and may take more than a season to be noticeable. If you choose to sharpen disc blades, check with local dealers for reputable experienced sharpeners that will stand behind their work.

Disc Gang Operation

The disc gang depth on the Finisholl is controlled independently from the overall depth of the implement. The gang depth is controlled hydraulically.

1. **Operation** – Disc gang depth is typically set 1" above the sweeps. This gives the sweeps a firm soil surface to operate in allowing them to cut and clean better. Avoid excessive depth and speeds; this will cause ridging. Avoid large changes in disc gang depth when operating in the field. Hydraulic disc gangs can be used to make minimal depth changes. Large disc gang depth changes will require the Finisholl to be re-leveled from front-to-rear to keep the sweeps operating level.



DANGER

Disc blades are extremely sharp. Exercise extreme care when working on or near disc blades. Do not allow discs to roll over or fall onto any bodily part. Do not allow wrenches to slip when working near disc blades. Never push wrenches toward disc blades. Failure to stay clear of disc blade edges can cause serious personal injury or death.

2. To set the depth of the hydraulic disc gangs, first fully extend the disc gang cylinders and hold the tractor lever at least 30 seconds. This will fully charge and rephase the disc gang hydraulics.
3. Fully retract cylinders and adjust cylinder anchor bolt until there is 9" between the top of the 22" disc gang blades and the bottom of the frame (**See Figure 4-15.**)
4. Adjust the wing disc gangs to match the center disc gangs by adjusting the cylinder anchor at the base of each wing frame gang cylinder. This will ensure that all disc gangs are set evenly across the machine.
5. Fully extend and rephase the hydraulic gang cylinders before starting each field operation. This will keep all cylinders in sync and gang depths consistent.

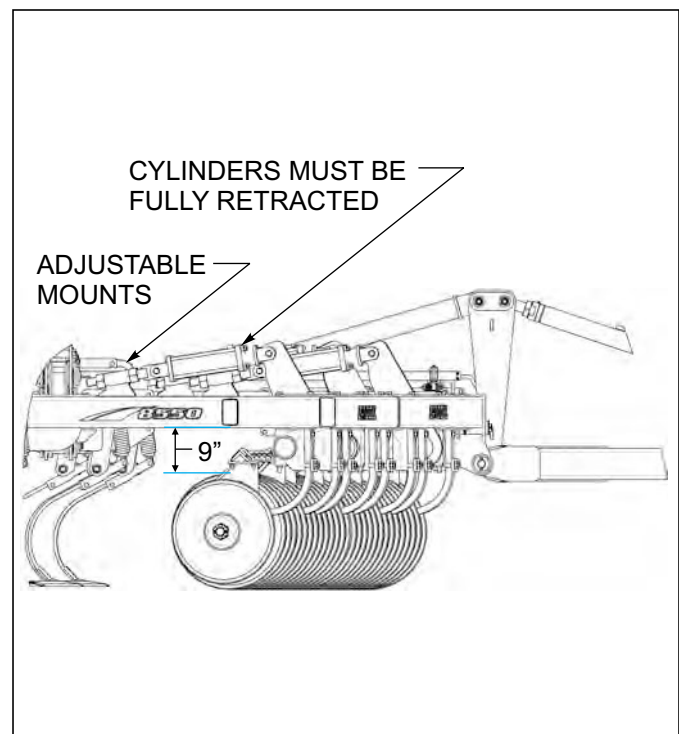

Figure 4-15: Disc Gang Operation

Disc Gang Assembly

1. The disc gangs are assembled using 1-3/4" diameter gang shaft. Spring-loaded end collars are used on each end of the disc gangs to maintain clamping force of the gang shaft. Slotted hex nuts are installed at both ends of the disc gangs to allow service from either end.
2. When disassembling a disc gang, note the locations of the bearings and tapered blades. Remove the 3/8 roll pin from the end of the gang shaft and clean any remaining soil or debris from the gang shaft threads. Closed-end gang shaft wrenches are provided on the center frame to fit the gang nuts. An additional extension or cheater pipe may be required to loosen the gang shaft.
3. When reassembling the disc gang, remove any soil or mud from the disc blades and spools to ensure a clean surface when tightening the gang. Clean the gang threads and install the gang nut. Torque the disc gang shaft to a minimum of 1200 ft-lbs (See Figure 4-16.)



DANGER

Disc blades are extremely sharp. Exercise extreme care when working on or near disc blades. Do not allow discs to roll over or fall onto any bodily part. Do not allow wrenches to slip when working near disc blades. Never push wrenches toward disc blades. Do not climb over machine above disc blades. Failure to stay clear of disc blade edges can cause serious personal injury or death.

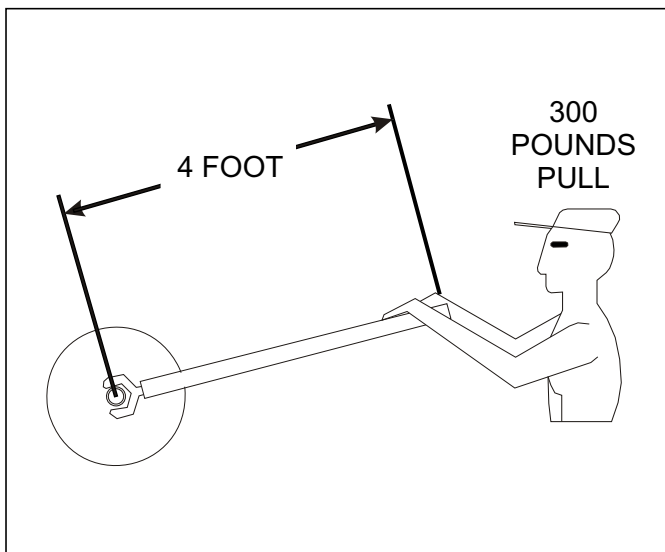

Figure 4-16: 1,250 Foot-Pounds of Torque

Scraper Adjustment

The Finisholl is equipped with rigid scrapers.

1. Rigid scrapers should be set initially as close to the disc blade as possible without rubbing (approximately 1/8") (See Figure 4-17.) A slotted hole at the top of each scraper is provided for individual adjustment. Adjustments may be made for entire gangs, by loosening the u-bolts around the angle-iron scraper bars and sliding the whole bar. Scraper arms are made of spring steel. In wet conditions, the scraper may be set against the disc blade and can function as a spring-loaded scraper.
2. Scraper blades have two positions and are reversible. The blades are initially set in the forward position to position scraper closer to the disc spool. This position will perform better in wet and heavier residue conditions. The blade may be moved rearward for more scraper action at the outer edge of the disc if desired.

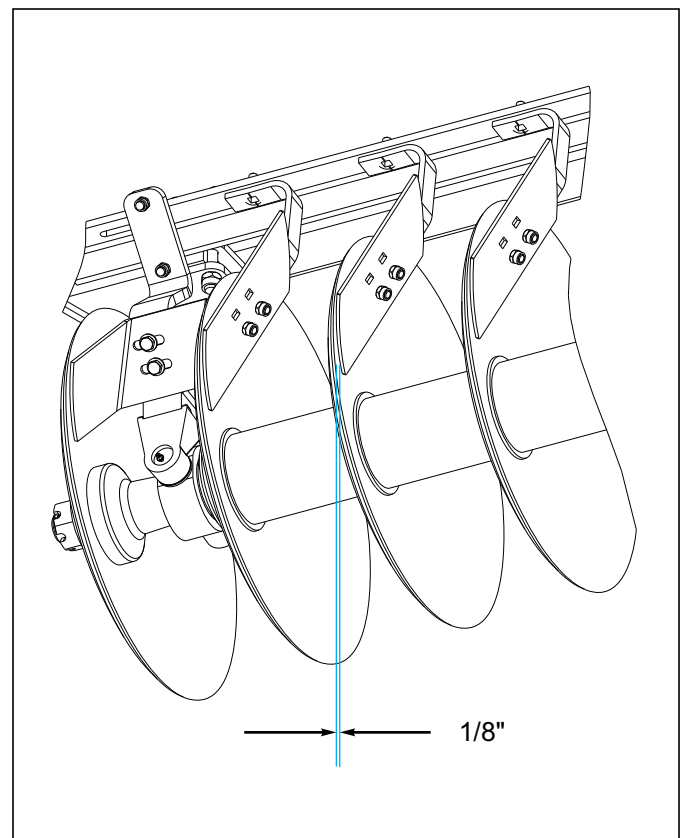

Figure 4-17: Scraper Adjustment

Shanks

The Finisholl is equipped with shanks on a four row pattern with an 8" shank spacing. Shank assemblies may be either s-tine or spring shanks.

S-tine Shanks

S-tine shanks may be used when there are no field obstructions such as rocks and stumps, and with flatter ground conditions. If fields contain rolling contours, terraces, or obstructions, spring shanks are recommended. There are no serviceable parts or adjustments for the s-tine shank assembly.

Spring Shanks

1. The Finisholl may be equipped with spring shanks. The spring shanks feature a 185 lb. point load and a 10" trip height to clear field obstructions. Shanks are 5/8 x 1-3/4 heat treated steel.
2. There is no regular maintenance required on the shanks. The main pivot point of the spring shank has replaceable hardened wear bushings that pivot on a heat treated clamp bushing.

NOTE

Main pivot bolt should be tightened securely to prevent rotation. Torque main pivot bolt to 140 ft.-lbs.

3. When adjusting or assembling the spring assembly, tighten the upper spring bolt, but leave approximately 1/8" gap above the spring jam nut (**See Figure 4-18.**) This will leave the proper clearance for the spring to pivot. Lock the jam nut against the top of the spring, not the top of the mount. Likewise, do not over tighten the lower spring cross bolt. Remove any slack in the bolt, but still allow the lower spring to pivot freely

Sweeps

The spring or s-tine shanks will accept a wide variety of sweeps and points. Recommended sweeps for the cultivator are standard 47° sweeps in 7 to 11 inch widths using 7/16 diameter mounting hardware. Check clearances when using larger sweeps to avoid interference with tires.

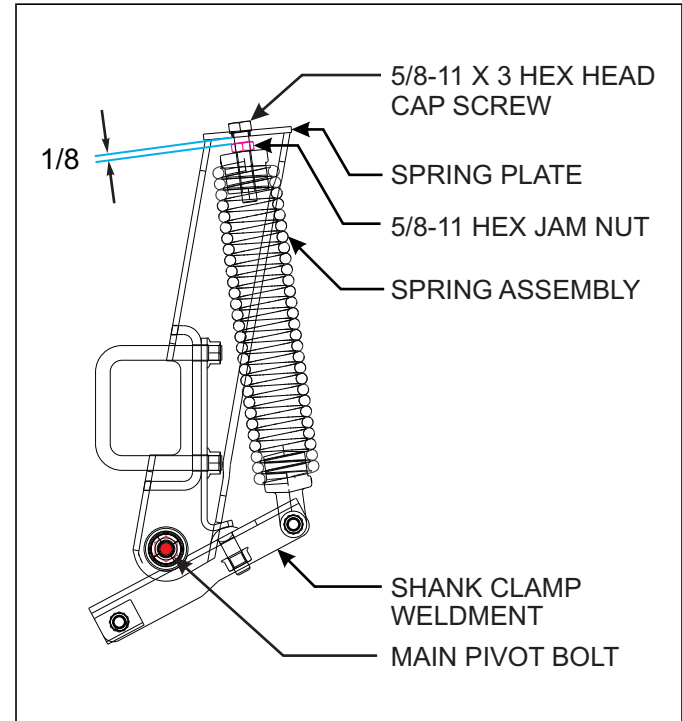

Figure 4-18: Spring Adjustment

Lubrication

1. A proper maintenance schedule will insure a long operating life and peak performance. Performing the following lubrication will ensure maximum operating life of the Finisholl (**See Table 4-1 and Figure 4-19.**)
2. When lubricating the Finisholl, SAE multi-purpose EP grease, or EP grease with 3-5% molybdenum sulfide is recommended. Wipe soil from fittings before greasing. Replace any lost or broken fittings immediately.
3. Disc gang bearings are equipped with triple-lip seals that will let grease pass and not harm the seal. Regular lubrication will maintain a full grease cavity and help purge any contaminants. Grease the bearings before long periods of storage to prevent moisture buildup within the bearing cavity.
4. Wheel seals, when properly installed, will allow grease to pass without harm to seals. Regular lubrication will extend service life, particularly in severe operating conditions.
5. The Finisholl is equipped with maintenance-free bearings in the wheel lifts, self-leveler, and wing hinges. These areas require no lubrication.

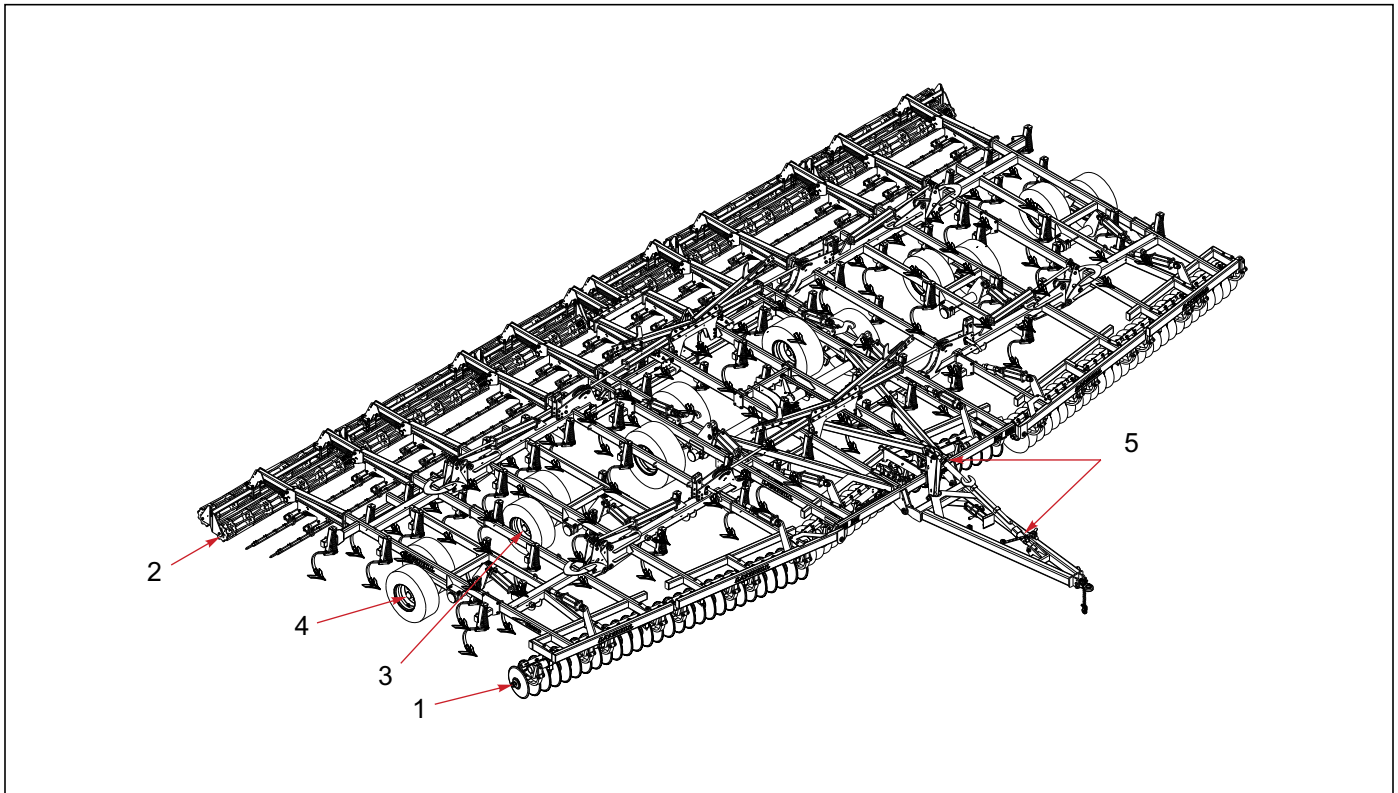

Figure 4-19: Lubrication Schedule

LUBRICATION TABLE			
ITEM	DESCRIPTION	NO. OF LUBE POINTS	INTERVAL (Hours Unless Stated)
1	Disc Gang Bearings	1 each	10
2	Conditioner Reel Bearings	1 each	10
3	Walking Tandem Hubs	1 each	50
4	Wheel Hubs	1 each	50
5	Radius Rod	1 each	50

Table 4-1: Lubrication Table

8550 Finisholl Wheel Bearing Maintenance

Center Frame

Center frame wheel bearing maintenance should be performed at the beginning of every season. Check periodically for excessive endplay. If needed, adjust or replace hub and components using the following procedure (**See Figure 4-20.**)

NOTE

Center frame hubs can be greased until grease purges seals without damage to seal.

1. Lower machine until tires are off the ground, the depth stop may have to be adjusted to allow cylinders to retract far enough.
2. Remove tires.
3. Remove hub cap and catch lubricant.
4. Straighten tab of star washer, remove outer spindle nut, star washer, spindle locking washer, inner spindle nut and bearing. Remove hub from spindle.
5. Using an appropriate driver, remove inner bearing cone and seal.
6. Clean and inspect the bearings and hub cavity. Replace any worn or defective parts.
7. Repack the bearings using a high-quality wheel bearing grease. Apply grease to bearing cups and a liberal amount to the center void.
8. Install inner bearing and seal, using the correct seal driver, into hub.
9. Place the hub over the spindle being careful to align the hub bore with the spindle to prevent seal damage. Support the hub until the outer bearing cone and spindle nut are installed.
10. Torque inner nut to 100 ft.-lbs. while rotating hub to insure proper seating of bearings and cups.
11. Loosen the inner spindle nut to remove preload torque.
12. Hand tighten the inner adjustment nut until contact is made with bearing.
13. Install the spindle nut lock washer so that the dowel on the inner nut will align with a hole in the lock washer and washer tang fits in the spindle keyway.
14. Install the star washer aligning tang with spindle keyway.
15. Apply grease to one side of the outer nut and install with grease to the star washer side.
16. Torque outer nut to 300 ft-lbs. Endplay of .001" to .010" must be present in the adjust wheel bearing assembly.
17. Bend over two tabs of star washer that is aligned with a flat on the outer nut to prevent rotation.
18. Grease interior of cap lightly to prevent any corrosion.
19. Install the hub cap with the proper gasket. Tighten the cap screws of the hub cap to 15 to 20 ft-lbs of torque.
20. Reinstall tires, making sure wheel spacer is on hub.
21. Torque dual wheel nuts to 450-500 FT/LBS.

NOTE

The spindle lock washer may be flipped over if needed to achieve a closer match to aligning with the dowel on the inner nut. Inner nut may also need to be rotated slightly for alignment.

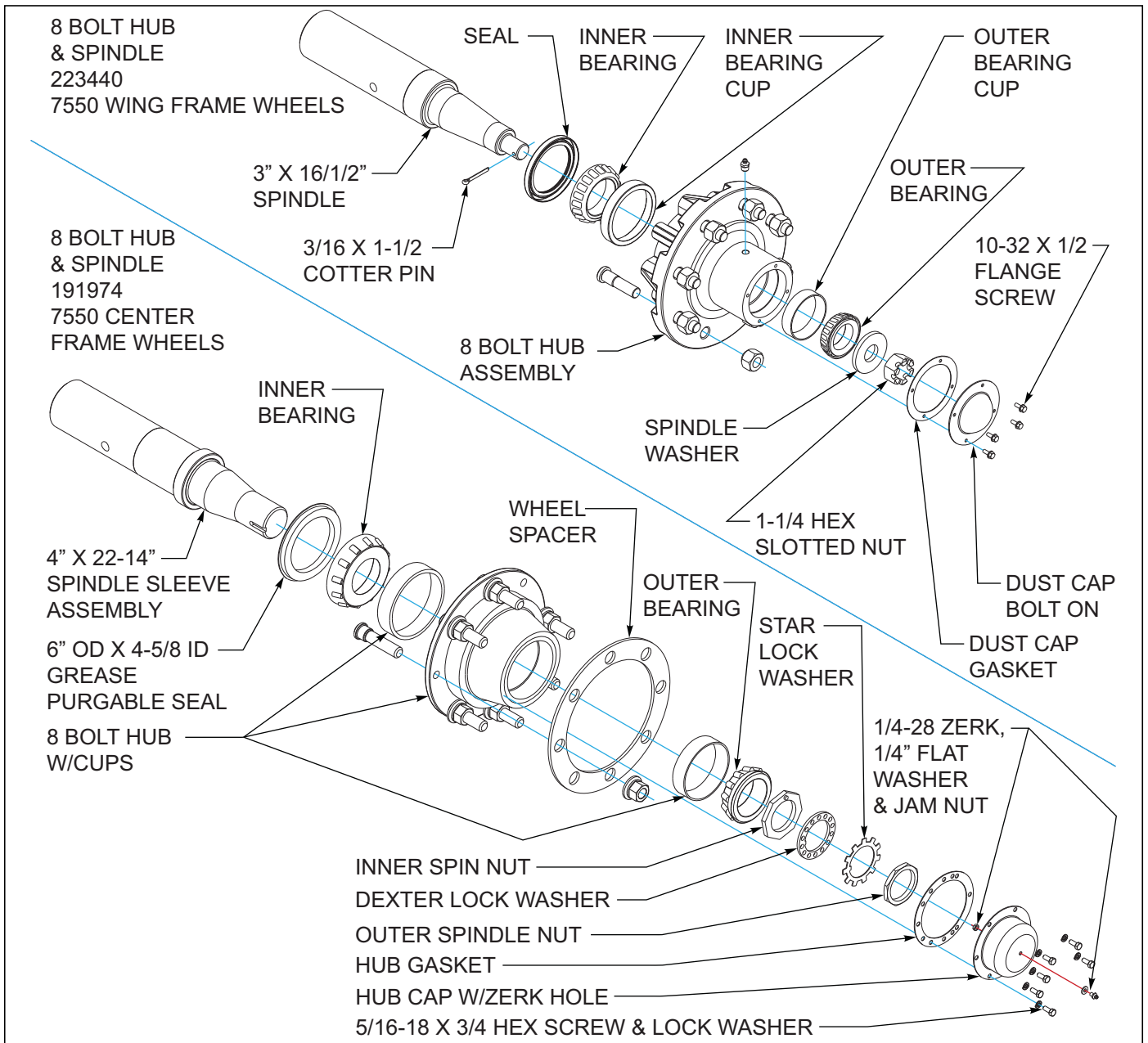

Figure 4-20: Wheel Bearing Maintenance

Wing Frame - Wheel Bearing Maintenance – Non Triple-Lip

Transport tires use a self-contained seal with multiple lips. The seal fits tight on both the spindle and wheel hub. The seal when properly installed will rotate internally and freely. This seal is will also allow grease to pass when lubricating the hub.

Wheel bearing maintenance should be performed at the beginning of every season of use. Check the wheel bearings periodically for excessive end play. If needed, adjust or replace them using the following procedure:

1. Place the frame on blocks or stands sufficiently to lift the tire clear of the ground.
2. Remove the tire.
3. Remove the dust cap, gasket, cotter pin, slotted nut, and washer.
4. Remove the hub assembly from the spindle. Clean and inspect the bearings and hub cavity. Replace any worn or defective parts.
5. **Repack** the bearings using a high-quality wheel bearing grease.
6. Install the inner bearing into the hub and install new grease seal. Use a driver to install the seal, to avoid damaging the outer edge of the seal. Drive the seal squarely into the hub to avoid any seal distortion.
7. Slide the hub, bearing, and seal onto a clean spindle.
8. Install the outer bearing, washer, and slotted nut.
9. Tighten the slotted nut while rotating the hub until there is a slight resistance to hub rotation. Then back the slotted nut off one notch or torque to 30-35 FT-LBS. A new seal will have some resistance, making the hub turn a little harder than usual.
10. Install a new cotter pin. Before installing the cap, fill hub with grease with grease gun through the zerk until it starts coming out around the washer.
11. Install the gasket and dust cap. Do not over tighten the dust cap screws causing the gasket to come out.
12. Through the zerk, give 6-8 more pumps of grease. It is not necessary to purge grease through a new seal, as they are filled (**See Figure 4-21.**)

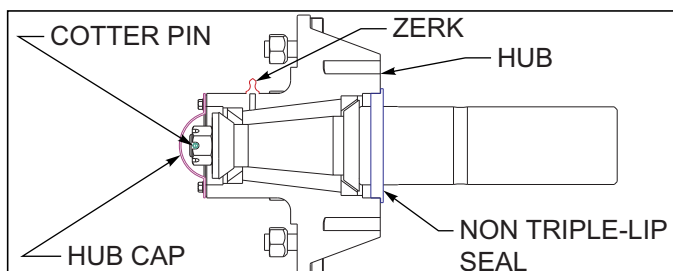

Figure 4-21: Non-Triple Lip-Seal

Wheel Bearing Maintenance -- Triple-Lip

Wheel bearing maintenance should be performed at the beginning of every season of use. Check the wheel bearings periodically for excessive end play. If needed, adjust or replace them using the following procedure:

1. Place the frame on blocks or stands sufficient to lift the tire clear of the ground.
2. Remove the tire.
3. Remove the hub cap, cotter pin, slotted nut and washer.
4. Remove the hub. Clean and inspect the bearings and hub cavity. Replace any worn or defective parts.
5. Repack the bearings using a high-quality wheel bearing grease.
6. Slide the triple-lip seal onto the spindle. Do not install the seal into the hub.
7. Slide the inner bearing cone and hub onto the spindle.
8. Install the outer bearing cone, washer and slotted nut.
9. Tighten the slotted nut while rotating the hub until there is a slight resistance to wheel rotation. Then, back the slotted nut off one notch, until the wheel rotates freely without end play.
10. Slide the triple-lip seal to the hub and install the seal in the hub.

NOTE

The triple-lip seals should point away from the hub to keep contaminants out and allow grease to pass (See Figure 4-22.)

13. Install a new cotter pin and replace the hub cap. (**See Figure 4-22.**)

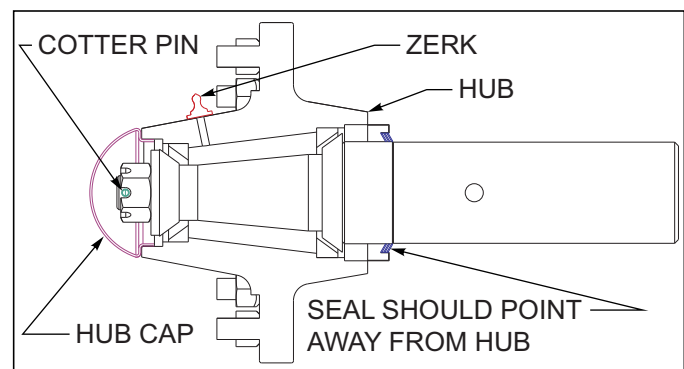

Figure 4-22: Triple Lip-Seal

4 Row Coil Tine Harrow Adjustments

1. The 4 row coil tine harrow option has 4 rows of 7/16" diameter x 18" long spring steel tines on 16" centers with overall spacing of 2" working centers. Tine rows are on 13" centers for enhanced residue flow. Tine tooth angle is also adjustable from the rear of each section. Each harrow section is mounted with two arms with spring-loaded down pressure. Tine teeth may individually rotate freely backward if needed for backup protection



WARNING

Know and verify actual implement height and width before transporting. Attachments may increase the overall height and width of the implement. Use caution when transporting near power lines. Electrocution can occur without direct contact.

2. In general tine harrows have better capabilities for handling more residue and wetter conditions. When operating the coil tine harrow, a more vertical tine tooth angle will make the harrow more aggressive. A lower/flatter tine angle will make the harrow less aggressive but will handle more residue and wetter conditions. To change the tine angle, raise the harrow off the ground. Remove the harrow pin from both angle adjustment tubes per tine gang bar tube **See Figure 4-23..** Rotate the angle adjustment tubes forward (less aggressive) or rearward (more aggressive) and reinstall both spring clip pins. Repeat the tine adjustment for each tine gangbar tube and harrow section.
3. The harrow sections should run level from front-to-rear when working in the field. Pull the harrow a short distance at the desired working depth. Stop the tractor and leave the cultivator/harrow in the ground, verify that the harrow section is level or slightly higher in the front.
4. To adjust the harrow section, raise the cultivator till the harrow clears the ground. Remove the 1/2 x 1-1/4 round head square neck screws from the angle adjustment plate on both section harrow arms. Support the back of the harrow section when removing the bolts. Rotate the harrow section to the desired set of adjustment holes and reinstall the 1/2 x 1-1/4 screws back in the angle adjustment plate.
5. The initial setting for the spring assembly should be 22". Each harrow section may also be adjusted for operating height. To change the harrow height **See Figure 4-23.**, loosen both 1-8 hex nuts against the spring end. Raise or lower the harrow arm by turning the bolt head for the spring adjustment bolt. Then re-tighten the 1-8 hex nuts. When initially setting the harrow height, the bottom tips of the tine tooth (pulled back at the desired tooth angle) should be approximately level with the field cultivator sweeps.

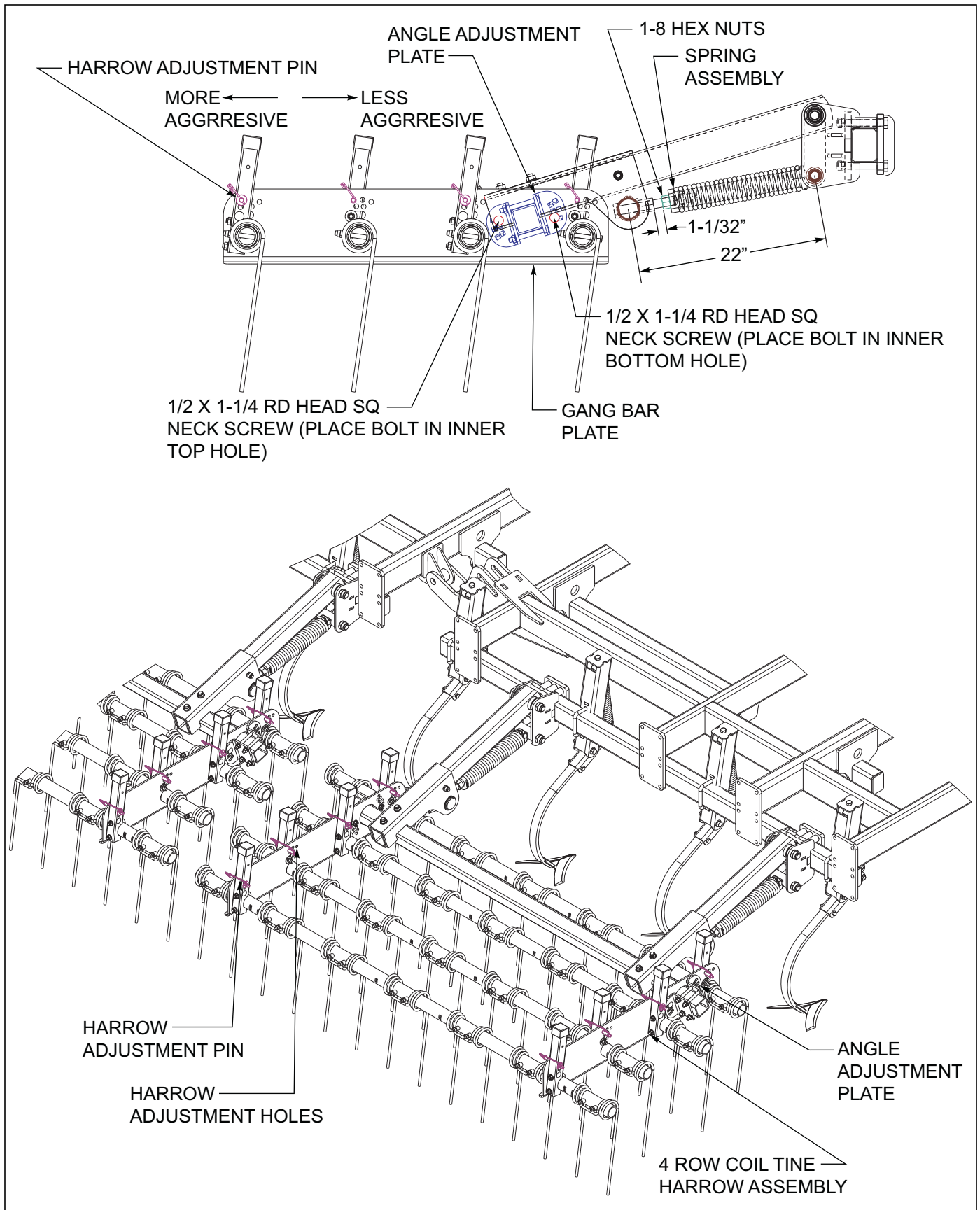

Figure 4-23: 4 Row Coil Tine Adjustment

3 Row Coil Tine and Reel Adjustments

1. The optional 3 row coil tine and reel attachment consists of a 3 row coil tine and finishing reel combination harrow that operate independently from each other. The 3 row coil tine reel harrow performs best in clean dry ground with minimal residue, to level, break up clods, and firm soil.
2. The 3 row coil tine harrow option has 3 rows of 7/16" diameter x 18" long spring steel tines on 16" centers with overall spacing of 2" working centers. Tine rows are on 14" centers for enhanced residue flow. Tine tooth angle is also adjustable for each tine bar end section. Each harrow section is mounted with two arms with spring-loaded down pressure. Tine teeth may individually rotate freely backward if needed for backup protection



WARNING

Know and verify actual implement height and width before transporting. Attachments may increase the overall height and width of the implement. Use caution when transporting near power lines. Electrocutation can occur without direct contact.

3. In general tine harrows have better capabilities for handling more residue and wetter conditions. When operating the coil tine harrow, a more vertical tine tooth angle will make the harrow more aggressive. A lower/flatter tine angle will make the harrow less aggressive but will handle more residue and wetter conditions. To change the tine angle, raise the harrow off the ground. Remove the harrow pin from both angle adjustment tubes per tine gang bar tube **See Figure 4-24..** Rotate the angle adjustment tubes forward (less aggressive) or rearward (more aggressive) and reinstall both spring clip pins. Repeat the tine adjustment for each tine gang bar tube and harrow section.

4. The harrow sections should run level from front-to-rear when working in the field. Pull the harrow a short distance at the desired working depth. Stop the tractor and leave the cultivator/harrow in the ground, verify that the harrow section is level or slightly higher in the front.
5. To adjust the harrow section, raise the cultivator till the harrow clears the ground. Remove the 1/2 x 1-1/4 round head square neck screws from the angle adjustment plate on both section harrow arms. Support the back of the harrow section when removing the bolts. Rotate the harrow section to the desired set of adjustment holes and reinstall the 1/2 x 1-1/4 screws back in the angle adjustment plate.
6. Each coil tine harrow may be adjusted for spring pressure as well **See Figure 4-24..** Raise the tine harrow off the ground. Remove the clevis pin from the spring tube and install in a heavy or light setting as needed. **Excessive spring pressure and tine angle can overload harrow spring.**

NOTE

The tine teeth will hang straight down when the implement is raised, and the tines will be slightly lower than the sweeps.

7. To adjust the reel height, loosen the locking hex nut against the threaded spring end **See Figure 4-24..**
8. Raise or lower the reel by turning the head of the spring bolt, and then re-tighten the locking nut against the spring end. Initially set the bottom of the reel even with the bottom of the sweeps. In lighter or wet soils, you may need to raise the reels slightly above the sweeps. Setting the reels too low may cause the reels to plug or push dirt. Excessive reel depth/down pressure may hold the rear of the field cultivator out of the ground.
9. Reels are equipped with maintenance-free bearings.

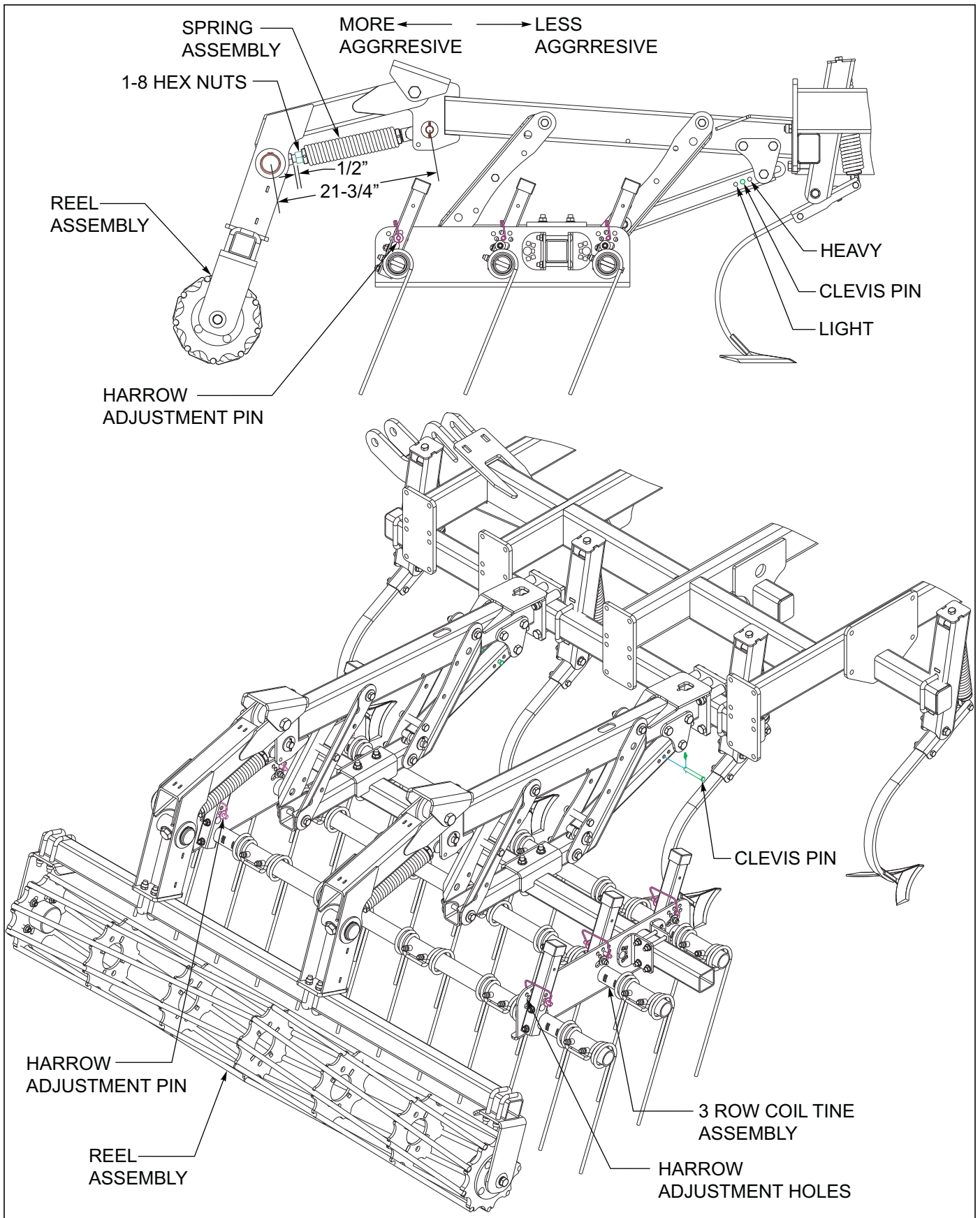

Figure 4-24: 3 Row Coil Tine and Reel Adjustments

5 Row Spike Harrow Adjustments

1. The 5 row spike harrow optional attachment consists of 5 rows of 3/4" x 14" long spike teeth, spaced on 9" centers. The spike teeth effectively work on 1.8" centers. Rank spacing for the angle iron bars is 14". Angle iron bars are able to float over contours and have backup protection. Spike tooth angle has a three position adjustment to either stand the teeth up for more aggressive action, or to lay the tooth down for lower aggressiveness and better residue clearance. The 5 row spike harrow performs best in clean ground with minimal residue, to level and break up clods.



WARNING

Know and verify actual implement height and width before transporting. Attachments may increase the overall height and width of the implement. Use caution when transporting near power lines. Electrocutation can occur without direct contact.

2. For the most aggressive spike to action, install the harrow adjustment pin in the forward mounting hole over each bar clamp for each spike bar **See Figure 4-25..** This will position the spike teeth to be in the most vertical position. In wetter or conditions with some residue, lower the spike tooth angle by positioning the harrow adjustment pin in the middle or rear hole. This will allow the teeth to lay flatter and shed more residue.
3. The forward pull chain will also influence how the 5 row spike operates as well **See Figure 4-25..** A taller pull point and shorter adjusted pull chain can help to start residue through the harrow. A lower pull point with a longer adjusted pull chain will help the entire harrow to run flatter from front-to-rear, and be more aggressive for increased leveling. When adjusting the pull chain, insert the desired pulling link through the slotted hole in the pull chain bracket, and install a lynch pin thru the link to secure the chain in place. Make sure the pull chains are set evenly for each section.

NOTE

Do not extend the pull chain out so far that the vertical carrying chains are pulling the harrow through the field.

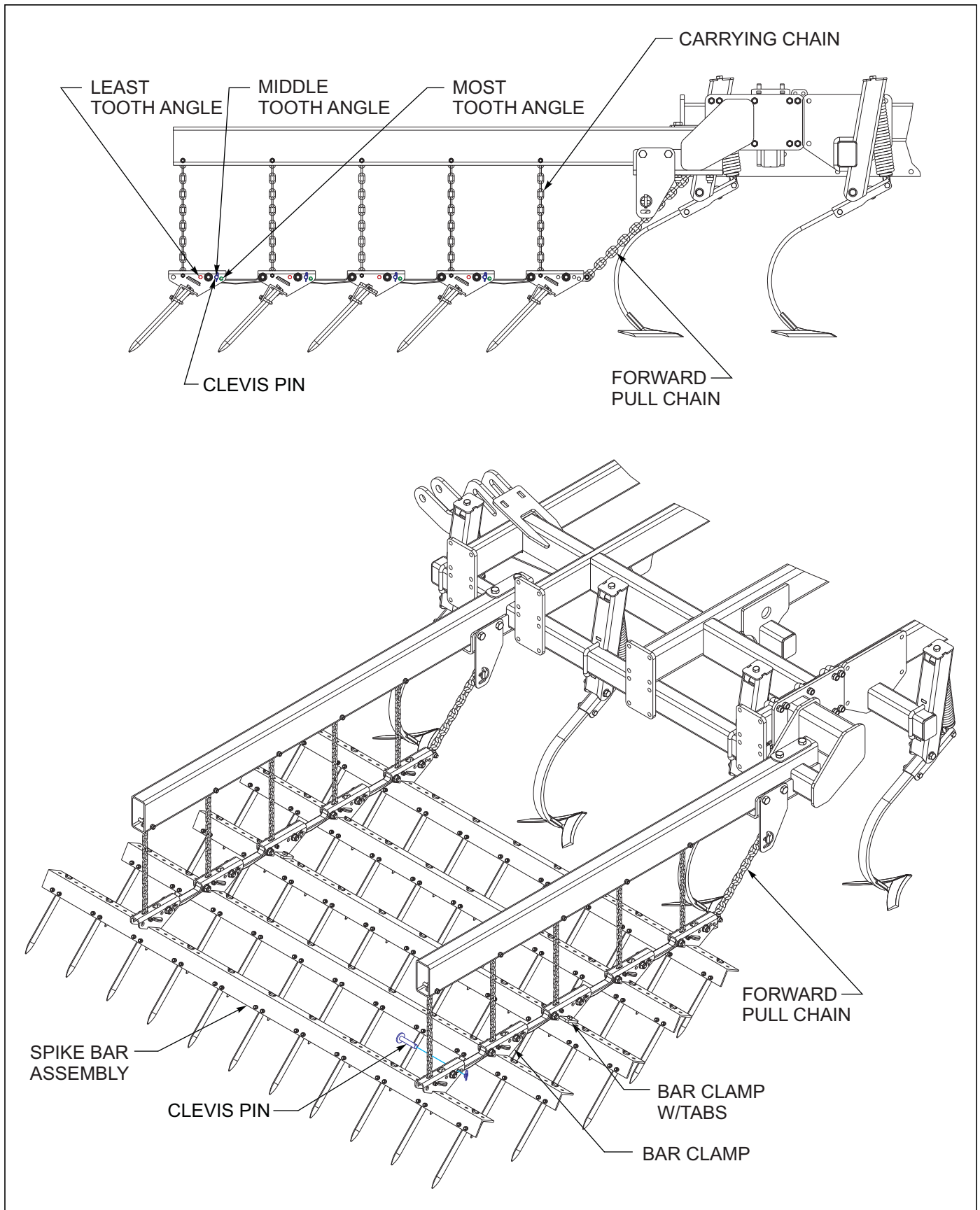

Figure 4-25: 5 Row Spike Harrow Adjustments

3 Row Spike and Reel Adjustments

1. The optional 3 row spike and reel attachment consists of a 3 row spike and finishing reel combination harrow that operate independently from each other. The 3 row spike reel harrow performs best in clean dry ground with minimal residue, to level, break up clods, and firm soil.



WARNING

Know and verify actual implement height and width before transporting. Attachments may increase the overall height and width of the implement. Use caution when transporting near power lines. Electrocution can occur without direct contact.

2. The 3 row spike consists of 3 rows of 3/4" x 14" long spike teeth, spaced on 9" centers. The spike teeth effectively work on 3.6" centers. Rank spacing for the angle iron bars is 14". Angle iron bars are able to float over contours and have backup protection. Spike tooth angle has a three position adjustment to either stand the teeth up for more aggressive action, or to lay the teeth down for less aggressiveness and better residue clearance.
3. For the most aggressive spike tooth action, install the harrow adjustment pin in the forward mounting hole over each bar clamp for each spike bar **See Figure 4-27..** This will position the spike teeth to be in the most vertical position. In wetter or conditions with some residue, lower the spike tooth angle by positioning the harrow adjustment pin in the middle or rear hole. This will allow the teeth to lay flatter and shed more residue.
4. The forward pull chain will also influence how the 3 row spike operates as well. A taller pull point and shorter adjusted pull chain can help to start residue through the harrow. A lower pull point with a longer adjusted pull chain will help the entire harrow to run flatter from front-to-rear, and be more aggressive for increased leveling. When adjusting the pull chain, insert the desired pulling link through the slotted hole in the pull chain bracket, and install a lynch pin thru the link to secure the chain in place. Make sure the pull chains are set evenly for each section.

NOTE

Do not extend the pull chain out so far that the vertical carrying chains are pulling the harrow through the field, or that the spike harrow gets into the reel.

5. The 12" diameter reel consists of nine 3/4" diameter round bars with a chevron shape for smoother rotation. The reels have no inner shaft to reduce plugging in wetter conditions. The reels operate independently of the 3 row spike with two spring loaded arms per reel to maintain consistent down pressure. A 12" diameter spiral wound reel with 1/4 x 1-1/2 angled blades is also available. The blades on flat bar reels are angled for more aggressive action. Install the reels as shown **See Figure 4-26..**

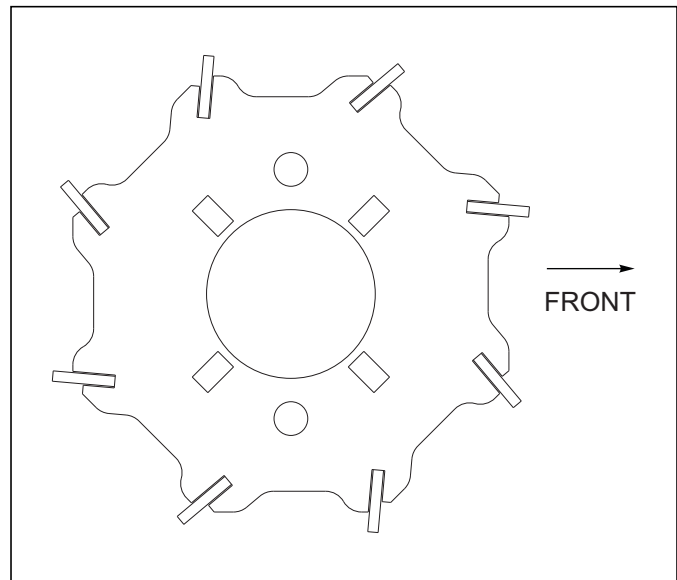

Figure 4-26: Flat Reel

6. To adjust the reel height, loosen the locking hex nut against the threaded spring end.
7. Raise or lower the reel by turning the head of the spring bolt, and then re-tighten the locking nut against the spring end. Initially set the bottom of the reel even with the bottom of the sweeps. In lighter or wet soils, you may need to raise the reels slightly above the sweeps. Setting the reels too low may cause the reels to plug or push dirt. Excessive reel depth/down pressure may hold the rear of the Finisholl out of the ground.
8. Reels are equipped with maintenance-free bearings.

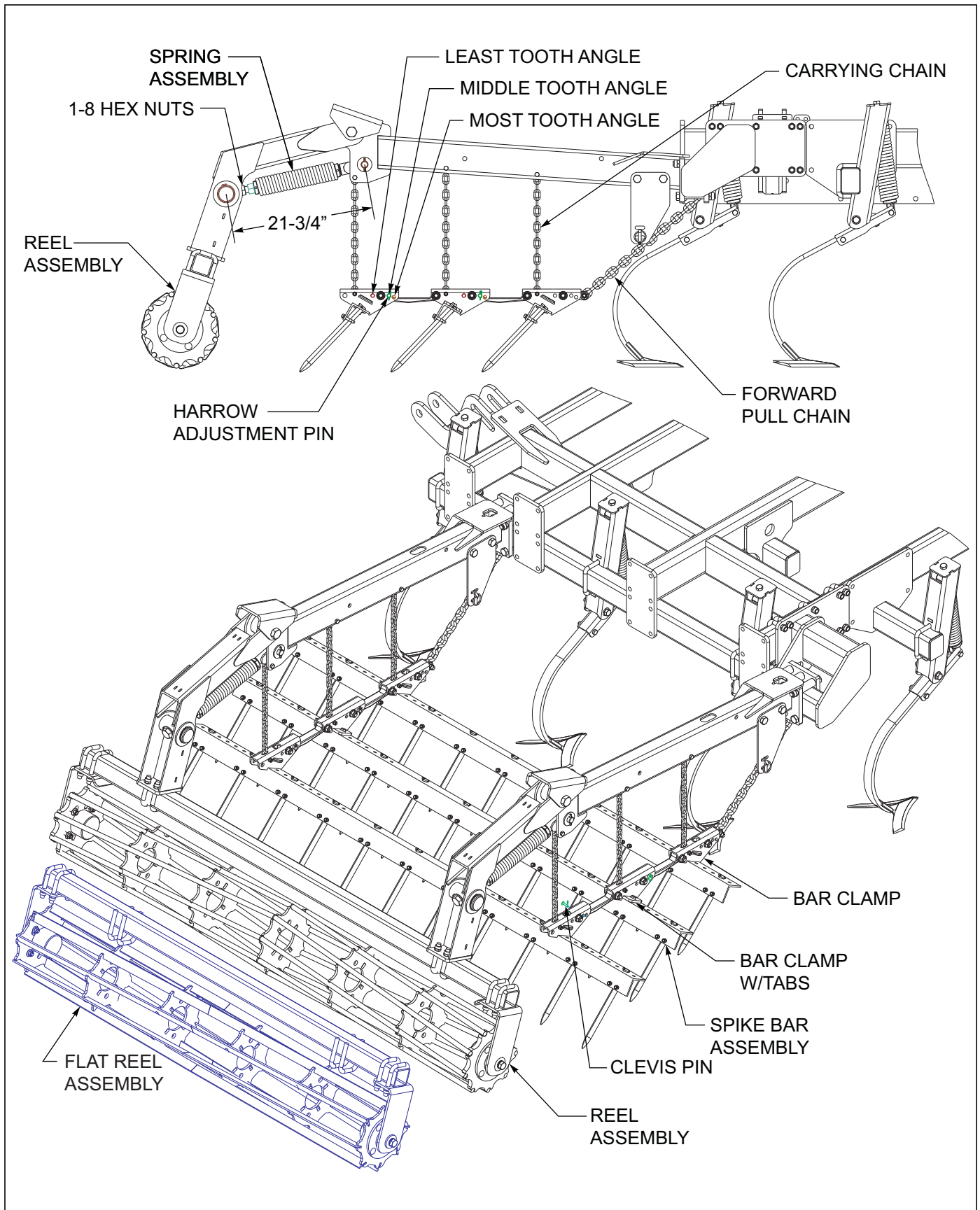

Figure 4-27: 3 Row Spike and Reel Adjustments

Chopper Reel & 3 Row Spike

1. The chopper reel and 3 row spike harrow operate independently to offer a very aggressive harrow for chopping and mixing soil and residue. The 16" dia reel helps to break up clods and mix the soil, followed by a 3-row spike harrow to smooth and level the soil. The chopper reel and 3 row spike will perform best in clean dry ground with minimal residue. Chopper reels are angled throw soil the opposite direction as the disc gang reels to help smooth and level the ground.



WARNING

Know and verify actual implement height and width before transporting. Attachments may increase the overall height and width of the implement. Use caution when transporting near power lines. Electrocutation can occur without direct contact.

2. Reel height is adjustable from 1" above the bottom of the sweeps to 3-1/2" above the sweep See Figure 4-29.. Initially the reels are set in the lowest position, which is 1" above the sweeps. The front and rear set of holes adjust in 1-1/4 increments, while the intermediate holes at the rear are in 5/8" increments. Keep the reel level as possible when making adjustments. To adjust the reel height, place a block under the reel to prevent the reel from falling. Lower the finisholl till the bottom two blades of the reel rest on the block. Do not try to support the reel on a single blade to prevent rolling. Loosen the front and rear reel mounting bolts for both reel harrow arms. Remove either the front or rear mounting bolts, but not both. Rotate the reel to the next higher or lower position and then reinstall the bolts. Adjust the opposite end of the reel mount as needed. Retighten the mounting bolts when finished. All reels should be set the same height across the machine.



WARNING

Chopper reels are heavy and sharp. Use caution and support the reels when making adjustments.

3. Chopper reels should be installed as shown See Figure 4-28. for correct chopping operation (**Note the direction of travel**). If the reels are installed backwards, the blade will contact the ground at a much flatter angle, and not chop or mix the soil as well.

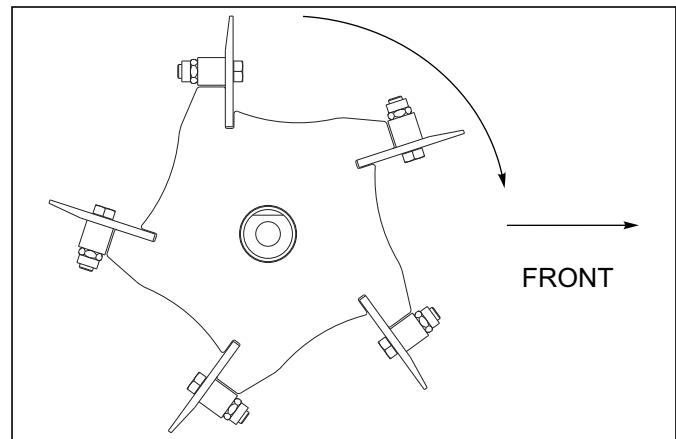

Figure 4-28: Chopper Reel Direction

4. Chopper reels prefer drier soils. Working the ground when the soil is too wet or too deep will cause the reel to plug. The aggressive action of the chopper reel tends to work deeper than typical finishing reels. Use caution when working in wetter conditions not to run the chopper reel too deep. Make sure the finisholl's depth is correct and the implement is running level front-to-rear.
9. The 3 row spike consists of 3 rows of 3/4" x 14" long spike teeth, spaced on 9" centers. The spike teeth effectively work on 3.6" centers. Rank spacing for the angle iron bars is 14". Angle iron bars are able to float over contours and have backup protection. Spike tooth angle has a three position adjustment to either stand the teeth up for more aggressive action, or to lay the teeth down for less aggressiveness and better residue clearance.
10. For the most aggressive spike tooth action, install the harrow adjustment pin in the forward mounting hole over each bar clamp for each spike bar See **Figure 4-29**. This will position the spike teeth to be in the most vertical position. In wetter or conditions with some residue, lower the spike tooth angle by positioning the harrow adjustment pin in the middle or rear hole. This will allow the teeth to lay flatter and shed more residue.

11. The forward pull chain will also influence how the 3 row spike operates as well. A taller pull point and shorter adjusted pull chain can help to start residue through the harrow. A lower pull point with a longer adjusted pull chain will help the entire harrow to run flatter from front-to-rear, and be more aggressive for increased leveling. When adjusting the pull chain, insert the desired pulling link through the slotted hole in the pull chain bracket, and install a lynch pin thru the link to secure the chain in place. Make sure the pull chains are set evenly for each section. Also do not extend the pull chain out so far that the vertical carrying chains are pulling the harrow through the field, or that the spike harrow gets into the reel.

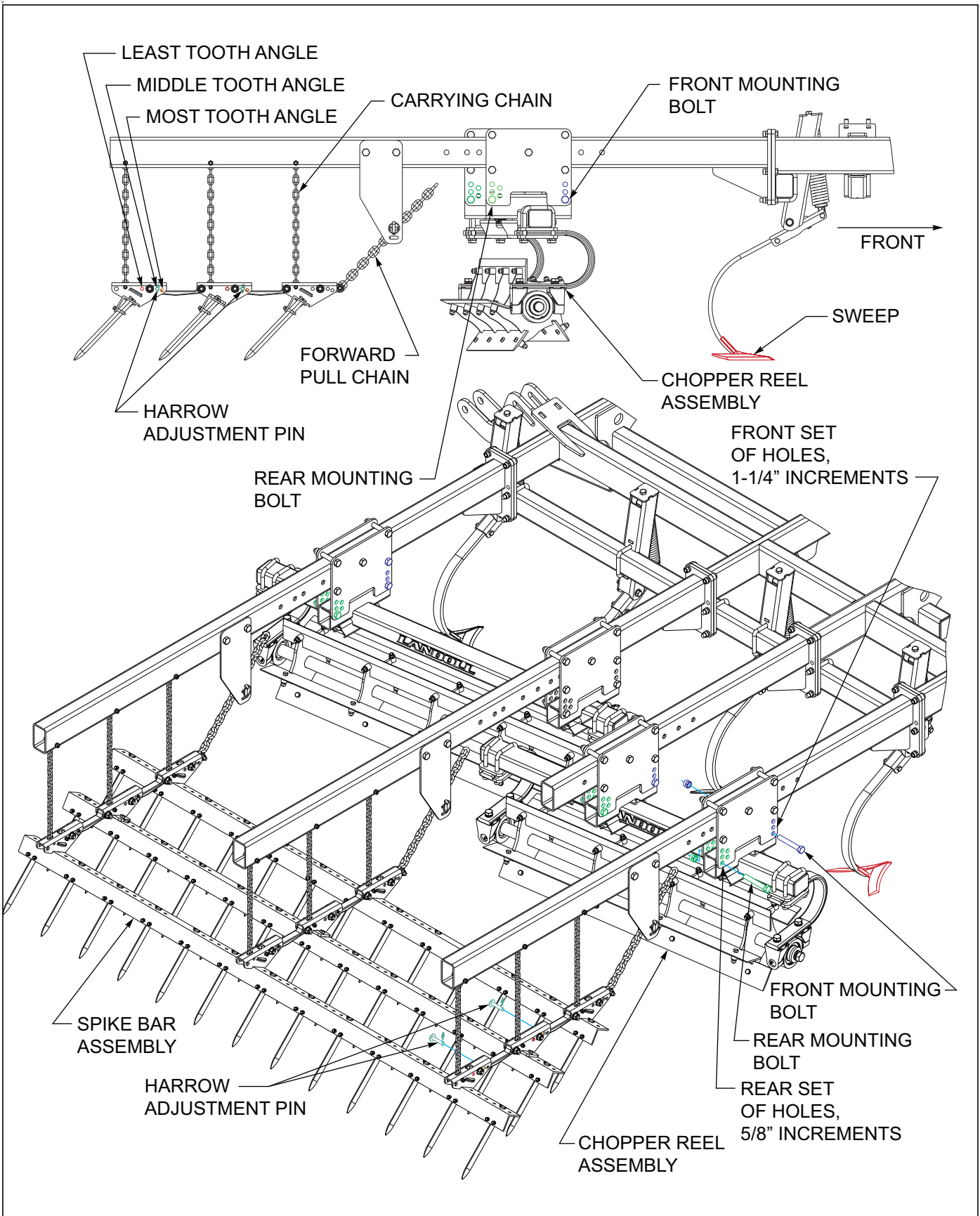

Figure 4-29: Chopper & 3 Row Spike Adjustments

Spike & Double Reel

1. The Spike and Double Reel Harrow consists of two rows of spring-loaded spike harrow bars and spring-loaded reels that operate independently. This harrow will perform best in clean dry ground with little or no residue.
2. Spike tooth bars have adjustable spring pressure and tooth angle, with backup protection. Heavy spring pressure and increased tooth angle will make the spike harrow more aggressive. Lower tooth angle and light spring pressure will make the harrow less aggressive and should be used for wetter and increased residue conditions.
3. To change the spike tooth angle See Figure 4-30., raise the finisholl so the harrow is off the ground. Remove the clevis pin at the lower end of each spike bar arm. Moving the pin to a higher adjustment hole will make the spike teeth stand more vertical and be more aggressive. Moving the clevis pin lower will allow the spike tooth to lay flatter and not as aggressive. Set the clevis pin adjustment the same for each end of the spike bar. Front spike bars may be set different than rear bars if desired.
4. The chain hooks on the spike bar arms are offset to allow the spring pressure to be changed See Figure 4-31.. The heavier setting should work for most conditions. To change the spike harrow spring pressure, first remove the pivot bolt through the spike harrow clamp and lower both spike bars for each section to the ground. Insert a $\frac{3}{4}$ " bolt/pin (not provided) through the harrow arm assembly hole.

NOTE

There is still spring tension on the harrow arms.

5. Remove the rear arm pivot bolt, holding the bottom of the arm to leverage the spring against the $\frac{3}{4}$ " assembly bolt/pin. Remove the front arm pivot bolt. Remove the $\frac{3}{16}$ retaining cotter pin from the both spring hooks. Remove the chain hooks and turn the offsets the desired setting. The closer the offsets face each other the lighter the spring setting, the farther apart, the heavier the setting. Reinstall the cotter pins. Connect the spring to the front harrow arm and reinstall the pivot bolt. Connect the spring to the rear harrow arm, and insert the top of the rear arm against the assembly pin. Pull the lower end of the rear harrow arm back until the rear pivot bolt can be installed. Reconnect the spike bar clamp to the harrow arms with the pivot bolts. Remove assembly pin when finished.

6. Use the rear spring assembly to adjust the height of the of the double reel assembly See Figure 4-30.. Initially set the reels to run approximately even with the bottom of the finisholl sweeps. To adjust the reel height, loosen the locking nut against the front of the spring assembly and the locking nut against the 2-1/2 dia adjustment pin. Rotate the head of the adjustment bolt to raise or lower the reel assembly. Retighten the locknuts against the spring end and the spring pin. Make sure the reel heights are set so the reels are even across the back of the finisholl.
7. The double reel assembly may also be adjusted for front-to-rear pitch See Figure 4-30.. The reels should run approximately level front-to-rear while working in the field. If ground conditions are very loose, or the reels try to push dirt, it may be necessary to run the front reel slightly higher than the rear reel. To change the reel pitch, lower the reels so they are just above the ground to prevent uncontrolled falling. Remove the two round head square neck $\frac{1}{2}$ x 1-1/4 screw and flange head nuts from each arm assembly. Rotate the double reel assembly to the desired pitch, and reinstall the screws. Adjust the reel pitch the same for all harrow sections.

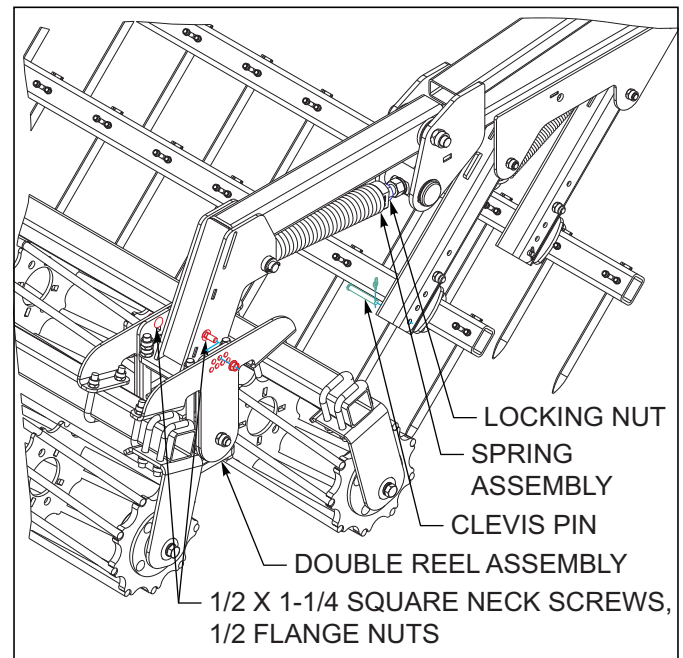

Figure 4-30: Spike Tooth Angle & Reel Adjustment

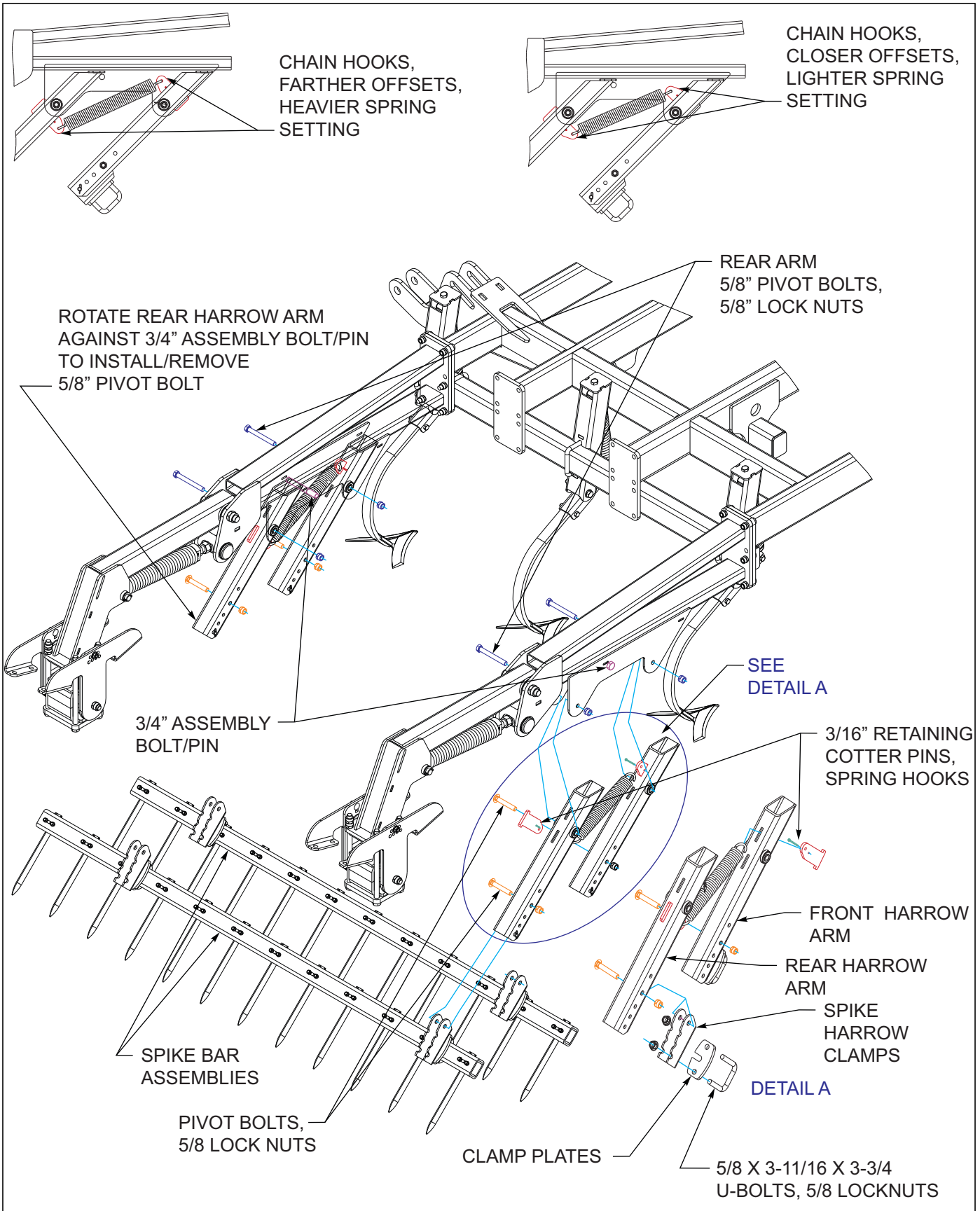

Figure 4-31: Spike & Double Reel Adjustments

Storage

The service life of the Finisholl will be extended by proper off-season storage practices. Prior to storing the unit, complete the following procedures:

1. Completely clean the unit.
2. Inspect the machine for worn or defective parts.
Replace as needed.
3. Repaint all areas where the original paint is worn off.
4. Grease all exposed metal surfaces of shanks, points and discs.
5. Lubricate each point of the machine as stated in **(Table 4-1.)**
6. Store the unit in a shed or under a tarpaulin to protect it from the weather. The ground tools and tires should rest on boards, or some other object, to keep them out of the soil.
7. If the unit must be stored outside, unfold the Disc to prevent moisture buildup in the disc gang and wheel bearings.
8. If the unit is stored in the folded position, make sure the transport lock pins are installed to prevent wing frames settling.

Troubleshooting Guide

The Troubleshooting Guide, shown below, is included to help you quickly locate problems that can happen using your 8550 Finisholl. Follow all safety precautions stated in the previous sections when making any adjustments to your machine.

PROBLEM	PROBABLE CAUSE	SOLUTION
FIELD NOT LEVEL BEHIND FIELD CULTIVATOR	Wing(s) not level with center frame	<ul style="list-style-type: none"> Hyd lift cylinders out of phase. Raise field Finisholl and hold hydraulic lever until all lift cylinders are completely extended. Fully extend all wing fold cylinders to allow wings to flex over uneven ground. Level machine side-to-side, by adjusting wing lift arms, so wing frames operate same depth as center frame.
	Hydraulic cylinder leaking	Repair cylinder.
	Unit not level front-to-rear	Adjust radius rod to level unit.
	Harrow improperly set	<ul style="list-style-type: none"> Adjust all harrow sections to operate the same depth. Increase harrow depth or increase tine/tooth angle to be more aggressive.
UNEVEN DEPTH	Wing(s) not level with center frame	<ul style="list-style-type: none"> Level center frame side to side. Level wing frames to center frame.
	Lift cylinders not in phase	Fully extend lift cylinders and hold hydraulic lever until all cylinders are fully extended.
	Lift wheels not carrying enough weight	Adjust depth stop and raise implement.
	Fold cylinders not fully extended to allow wings to flex	Extend fold cylinders fully.
	Tire pressure too low	Check inflation.
	Unit not level front-to-rear	Adjust unit to be level.
UNIT TRACKS TO ONE SIDE	Wing(s) not level with center frame	Level unit side to side.
	Tire pressure too low	Check inflation.
	Hydraulic cylinder leaking	Repair cylinder.
	Lift cylinders not in phase	Fully extend cylinders and hold hydraulic lever until all cylinders are fully extended.

TROUBLESHOOTING GUIDE

PROBLEM	PROBABLE CAUSE	SOLUTION
UNIT BOUNCES IN THE FIELD	Operating too fast	Typical operating speed 6-8 mph.
	Conditions too rough for speed	Make two passes if necessary.
DISC GANGS RIDGING	Gangs too deep	Raise disc gangs.
	Excessive speed	Reduce speed.
	Gangs not level across machine	Adjust disc gang depth/level gangs.
	Finishroll not level front to rear	Level unit front-to-rear.
	Wing(s) not level with center frame	Level wing to center section.
	Spray/dirt shields too high	Lower shields.
	Hydraulic cylinders not even	<ul style="list-style-type: none"> Rephase disc gang hydraulics. Repair leaking cylinder/hoses.
UNIT NOT LEVEL- SHANK TRACKS	Harrow improperly set	Adjust harrow.
	Incorrect sweeps	Use correct sweep angle/smaller sweeps.
	Shanks dragging residue	Disc gangs set too deep, raise gangs so sweeps cut firm soil
	Shank carrying soil, not scouring	Conditions wet, residue.
SHANKS PLUG WITH RESIDUE	Shanks not positioned correctly	Check for proper shank placement.
	Shank extensions not installed on spring shanks	Check for proper shank placement.
SHANK SPRINGS BREAKING	Lower spring pivot bolt too tight	Lower spring bolt must be loose enough that spring end casting may pivot freely.
	Upper spring bolt too tight	<ul style="list-style-type: none"> Should be 1/8 clearance between jam nut and top spring plate. Locking jam nut should be tight against spring end, not top spring plate.
SWEEPS NOT CUTTING, LEAVING SKIPS	Shanks not positioned correctly	Check for proper shank placement.
	Sweeps not wide enough	Use wider sweeps.
	Sweeps set too shallow	Increase operating depth.
	Incorrect sweep angle	Use 47 degree sweeps.
	Incorrect shank spring adjustment	Adjust spring shank.
	Bent/broken/loose shank or sweep	Repair shank or sweep.
WINGS FOLD TOO FAST	Restrictors not properly installed in cylinders	Black restrictor fittings should be in both ends of outer fold cylinders and rod end of inner fold cylinders.
HYDRAULIC - LIFT CYLINDERS NOT FULLY EXTENDING	Lift cylinders not in phase	Fully extend cylinders and hold hydraulic lever until all cylinders are fully extended.
	Cylinders not installed in proper series	Install cylinder in proper series. Wing cylinders are smaller diameter than center cylinders.
	Hoses not properly connected	Check hose routing.
	Bent/twisted main lift	Repair/replace main lift.
HYDRAULIC - ENTIRE UNIT SETTLING	Tractor valve leaking	Unplug unit from tractor, and check if unit still settling.
	Bad fitting/hose	Repair fitting/hose.
HYDRAULIC - UNIT SETTLING, ONE WING RAISING	Center frame cylinder leaking internally on side of unit that wing is raising	Repair center frame master cylinder.
HYDRAULIC - WING SETTLING	Wing cylinder leaking	Repair wing cylinder.

PROBLEM	PROBABLE CAUSE	SOLUTION
HYDRAULIC - UNIT WILL NOT FOLD/UNFOLD	Tractor valve not working	Try a different known working valve.
HYDRAULIC - DEPTH CONTROL VALVE NOT WORKING	Hydraulic hoses not properly connected	Check hose connections.
	Depth stop contacts depth control valve, but does not shut off oil	<ul style="list-style-type: none"> • Check for correct valve plumbing. • Check for valve leaking internally.
	Implement raises, but will not lower	Check valve or manifold for incorrect plumbing.
WHEEL BEARING FAILURE	Seals not properly installed	Triple-lip seals should be installed with lips pointing outward away from the hub.
HARROW PLUGS WITH RESIDUE	Harrow set too aggressive	Reduce tine/tooth angle to allow residue to flow thru harrow.
	Harrow spring pressure excessive	Reduce spring pressure/raise harrow.
HARROW REELS PLUGGING	Excessive down pressure	Reduce spring pressure/raise harrow.
HARROW REELS WILL NOT TURN OR PUSH SOIL	Depth set too deep for loose or wet conditions	Adjust reel operating depth.
	Reel bearing failure	Repair reel bearing.

Document Control Revision Log:

Date	Form #	Improvement(s): Description and Comments
11/01/2014	F-816	Initial Release
11/19/2018	F-816-1118	ECN44047 walking beam lube table updates
03/07/2022	F-816-0322	Added QR code. 20mph to rear of machine, updated decals, updated attachments



Intertek

Equipment from Landoll Company, LLC is built to exacting standards ensured by ISO 9001 registration at all Landoll manufacturing facilities.

Model 8550 Finisholl Operator's Manual

Re-Order Part Number F-816

LANDOLL COMPANY, LLC

1900 North Street

Marysville, Kansas 66508

(785) 562-5381

800-428-5655 ~ WWW.LANDOLL.COM



Copyright 2022. Landoll Company, LLC

“All rights reserved, including the right to reproduce this material or portions thereof in any form.”

Scan to go to www.landoll.com

