



D4P Power Ditcher Parts Manual



LANDOLL COMPANY, LLC

1900 North Street

Marysville, Kansas 66508

(785) 562-5381

800-428-5655 ~ WWW.LANDOLL.COM

Table of Contents

1 Instructions for Ordering Parts

1 Illustrated Parts List

GENERAL ASSEMBLY	1-1
MAIN FRAME ASSEMBLY	1-2
DECAL INSTALLATION	1-4

2 Numerical Index

Instructions for Ordering Parts

ORDER PARTS FROM LANDOLL PARTS DISTRIBUTION CENTER

**** Repair parts must be ordered through an Authorized Dealer ****

PHONE NO.: 1-800-423-4320 OR 1-800-428-5655 OR 1-785-562-5381

FAX NO.: 888-527-3909

ORDER ONLINE: companystore.landoll.com

IDENTIFICATION PLATE

The identification plate, which lists the model number and serial number, is located on the left side of the hitch (See Figure 1-1.)

SERIAL NUMBER NOMENCLATURE

The serial number for the D4P Series Power Ditcher is located on the identification plate.

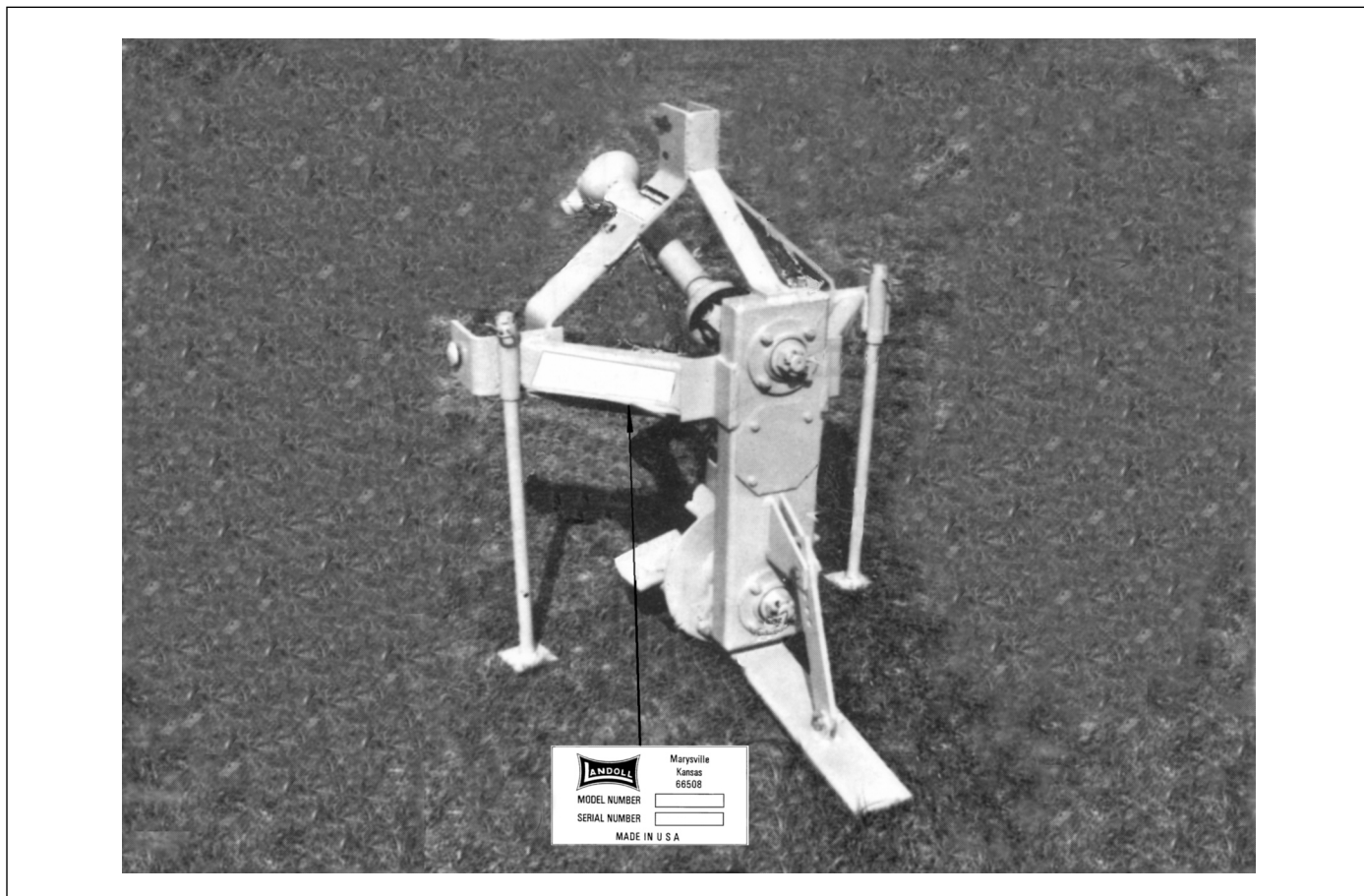

Figure 1-1: Identification Plate and Location

Page Intentionally Blank

Illustrated Parts List

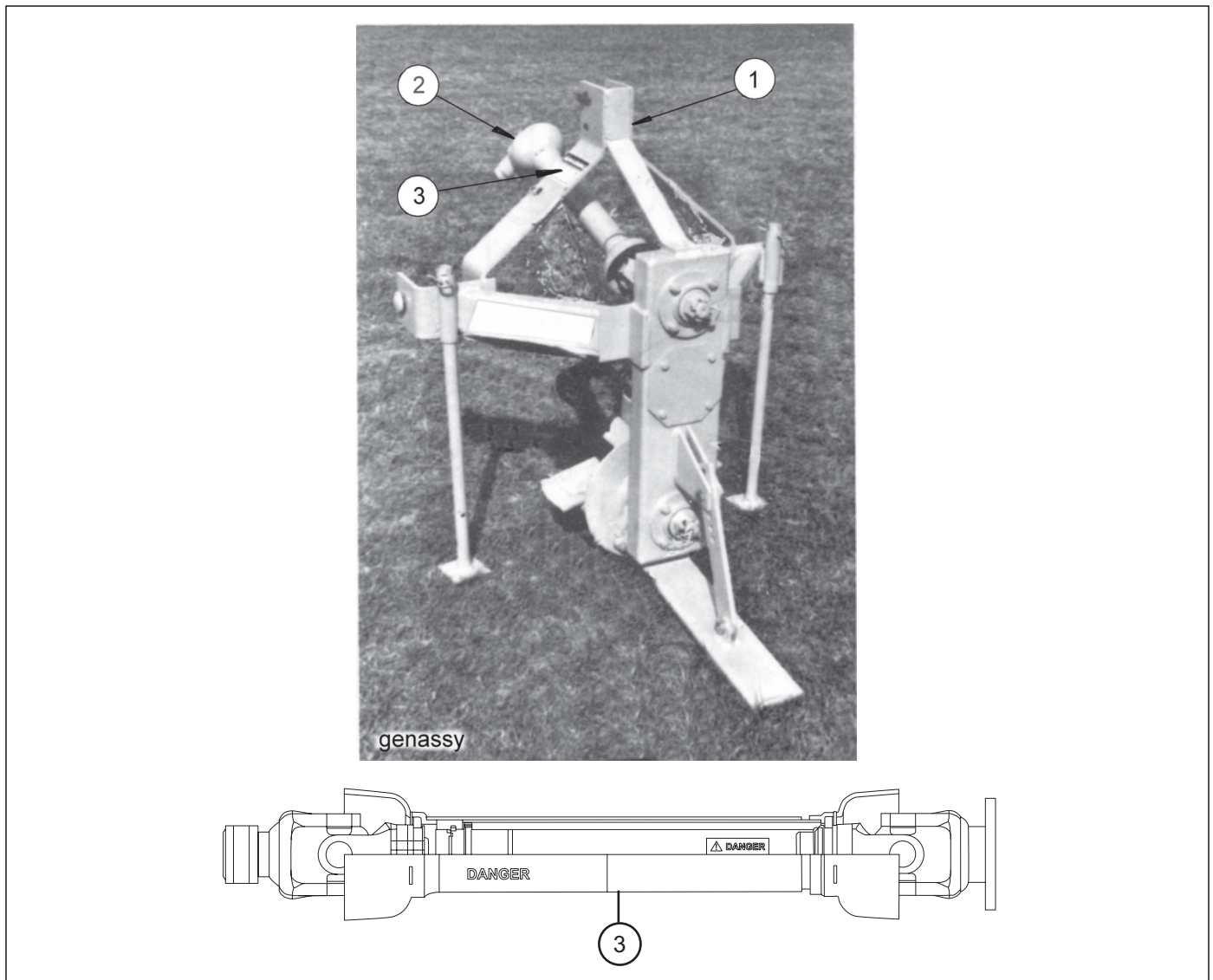

Figure 1-1: General Assembly

GENERAL ASSEMBLY

ITEM	PAGE/PART NO.	DESCRIPTION	QTY.
1	1-2 - 1-2	MAIN FRAME ASSEMBLY	1
2	165092	PTO 540-6 DRIVELINE	1
	165093	PTO REPAIR KIT	1
3	1-4	DECAL INSTALLATION	1
4	F-348	MANUAL, D4P POWER DITCHER OPER. (NOT SHOWN)	1



ILLUSTRATED PARTS LIST

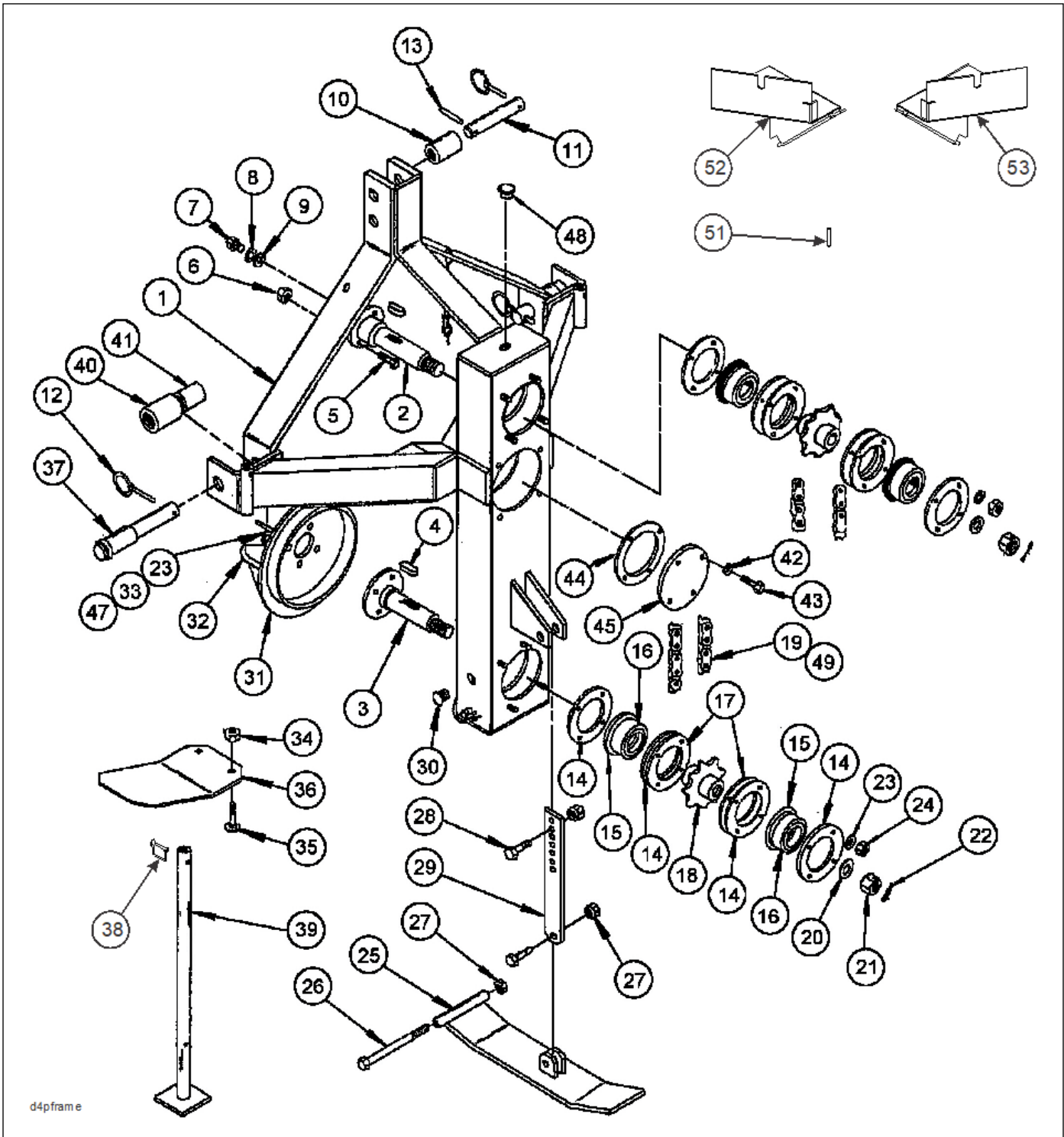

Figure 1-2: Main Frame Assembly

MAIN FRAME ASSEMBLY

ITEM	PART NO.	DESCRIPTION	QTY.
1	E0917	MAIN FRAME WELDMENT	1
2	E029	INPUT SHAFT	1
3	E030	OUTPUT SHAFT	1
4	EAI642	KEY	2

MAIN FRAME ASSEMBLY

ITEM	PART NO.	DESCRIPTION	QTY.
5	E10711AGCO	HEX BOLT 5/16 X 1-3/4 GR8	2
6	W915720-4	LOCK NUT 5/16-24	2
7	E10602	HEX BOLT 7/16 X 1 GR2	1
8	1-861-010034-12	WASHER, SPLIT LOCK 7/16	1
9	1-861-010032-15	WASHER, FLAT 1/2	1
10	E8193	BUSHING, 1" X .12 - 1-13/16 LONG	1
11	E100706	PIN, 3/4" DIA - 4-1/2 LONG	1
12	E10317	KLIK PIN, 1/4"	4
13	W933232	SPRING PIN, SLOTTED 5/16 X 2	1
14	017790	FLANGETTE	8
15	E7864	O-RING	4
16	E10771	BEARING	4
17	366273	GASKET, FLANGETTE	4
18	E1929	SPROCKET	2
19	7038-57	#80, 57 PITCHES	1
20	W920048-4	WASHER, 1-1/4	2
21	E10179	HEX NUT, 1-3/8 SLOTTED	2
22	W933221	SPRING PIN, 1/2 X 2	2
23	1-861-010034-13	WASHER, SPLIT LOCK 1/2	20
24	1-512-010007-09	NUT, HEX NUT 1/2	16
25	E0937	SKID	1
26	5/8-11X9 CS	SCREW, HEX HEAD CAP 5/8-11 X 9	1
27	103-0625	LOCK NUT, 5/8	3
28	1-654-010059-07	SCREW, HEX HEAD CAP 5/8-11 X 2-1/2 GR5	2
29	E100648	ADJUSTING BAR	1
30	W941049	PIPE PLUG 3/8 SOCKET H.D.	2
31	E025	HUB BLADE WELD	1
32	E100658	BLADE	4
33	E10498	LOCK NUT 1/2	8
34	1-512-010005-09	NUT, HEX LOCK 1/2	2
35	1-654-010070-03	SCREW, RD HEAD SQ NECK 1/2-13 X 1-1/2	2
36	E100699	DEFLECTOR	1
37	E0918	HITCH PIN	2
38	516-22PTL	RETAINING PIN	2
39	E0939	PARKING STAND	2
40	E100640	BUSHING, 1-7/16 X .156 - 2-3/4 LONG	2
41	E100661	SPACER 1-15/16 X 3/16 - 2-3/4 LONG	2
42	1-861-010034-11	WASHER, SPLIT LOCK 3/8	4
43	E10944	HEX BOLT, 3/8 X 3/4 GR5	4
44	E7865	GASKET, INSPECTION PLATE	1
45	E7861	INSPECTION PLATE	1
46	EUA74018	CUTTER HEAD ASSEMBLY (INCL. 31-33, 47)	1
47	E10705AGCO	HEX BOLT 1/2 X 1-1/4 GR5	12
48	E11293AGGO	PLUG BREATHER	1
49	7039-8	CONNECTOR LINK, #80	1
50	1-796-010001	TIE, WIRE 22 PLASTIC (NOT SHOWN)	AR
51	125520	PIN, SPRING SLOTTED 1/8 X 1-1/2	2
52	366557	SHIELD WELDMENT, LH	1
53	366558	SHIELD WELDMENT, RH	1

ILLUSTRATED PARTS LIST

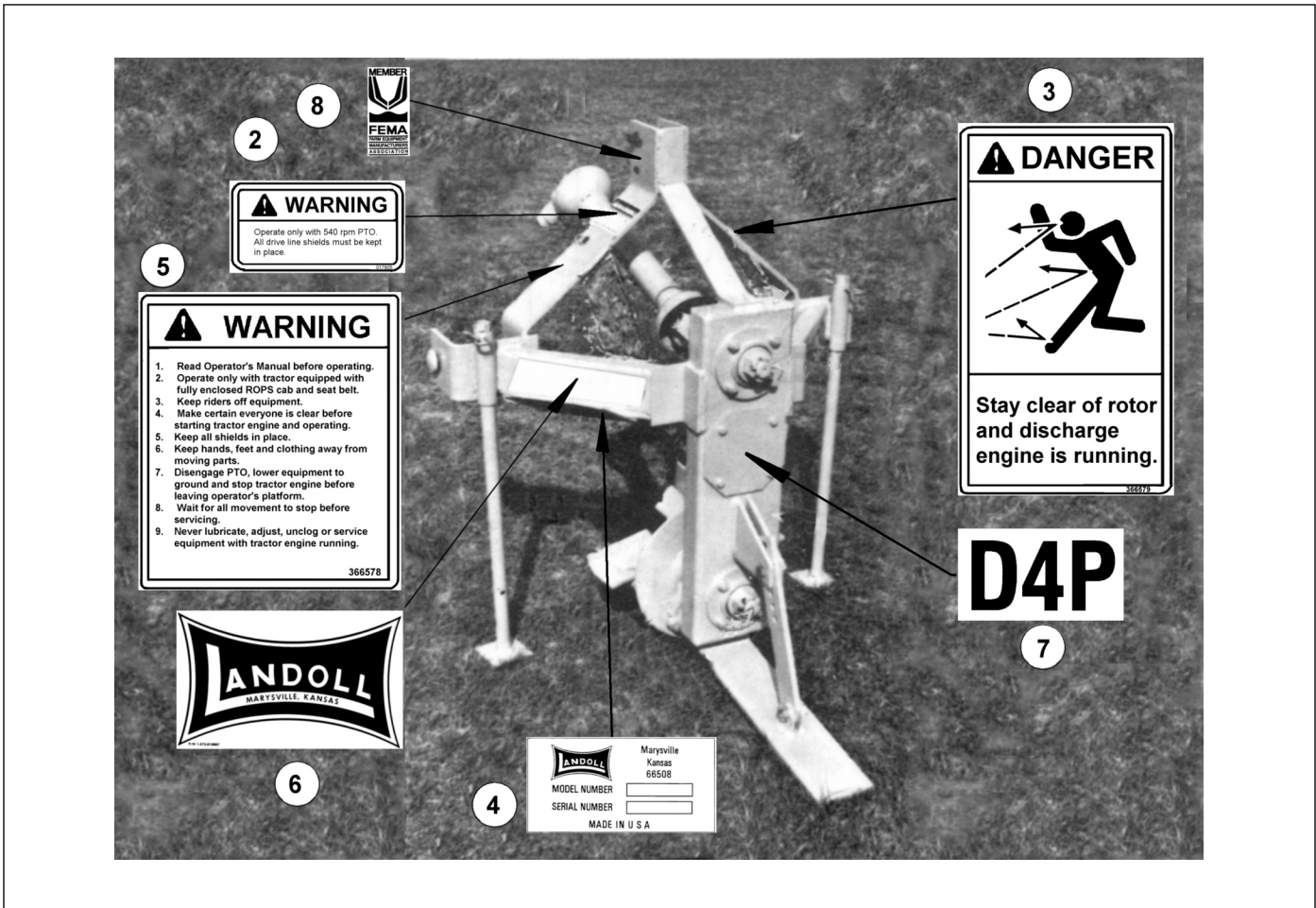

Figure 1-3: Decal Installation

DECAL INSTALLATION

ITEM	PART NO.	DESCRIPTION	QTY.
1	10036	FASTENER, SERIAL NO. PLATE	2
2	017805	DECAL, WARNING	1
3	366579	DECAL, DANGER	2
4	1-573-010006	PLATE, NAME	1
5	366578	DECAL, WARNING	1
6	141259	DECAL, LANDOLL YELLOW	2
7	162615	DECAL, MODEL D4P	1
8	2-573-010198	DECAL, MEMBER FEMA	1

Numerical Index

Numerics

017790	1-3
017805	1-4
10036	1-4
103-0625	1-3
1-2	1-1
125520	1-3
1-4	1-1
141259	1-4
1-512-010005-09	1-3
1-512-010007-09	1-3
1-573-010006	1-4
162615	1-4
165092	1-1
165093	1-1
1-654-010059-07	1-3
1-654-010070-03	1-3
1-796-010001	1-3
1-861-010032-15	1-3
1-861-010034-11	1-3
1-861-010034-12	1-3
1-861-010034-13	1-3
2-573-010198	1-4
366273	1-3
366557	1-3
366558	1-3
366578	1-4
366579	1-4
5/8-11X9 CS	1-3

516-22PTL	1-3
7038-57	1-3
7039-8	1-3

E

E025	1-3
E029	1-2
E030	1-2
E0917	1-2
E0918	1-3
E0937	1-3
E0939	1-3
E100640	1-3
E100648	1-3
E100658	1-3
E100661	1-3
E100699	1-3
E100706	1-3
E10179	1-3
E10317	1-3
E10498	1-3
E10602	1-3
E10705AGCO	1-3
E10711AGCO	1-3
E10771	1-3
E10944	1-3
E11293AGGO	1-3
E1929	1-3
E7861	1-3



NUMERICAL INDEX

E7864	1-3
E7865	1-3
E8193	1-3
EAI642	1-2
EUA74018	1-3

F

F-348	1-1
-------------	-----

W

W915720-4	1-3
W920048-4	1-3
W933221	1-3
W933232	1-3
W941049	1-3



Intertek

Equipment from Landoll Company, LLC is built to exacting standards ensured by ISO 9001:2008 registration at all Landoll manufacturing facilities.

Model D4P Power Ditcher Parts Manual

Re-Order Part Number F-350

LANDOLL COMPANY, LLC

1900 North Street

Marysville, Kansas 66508

(785) 562-5381

800-428-5655 ~ WWW.LANDOLL.COM



Copyright 2014. Landoll Company, LLC

"All rights reserved, including the right to reproduce this material or portions thereof in any form"